

7201-02 Computing Element

www.ibm360.info

SFN-0205-1

IBM Parts Catalog

Preface

This Parts Catalog contains listings and illustrations of all replaceable assemblies, subassemblies and detail parts released to Production Control on or before October 31, 1971 for the 7201-02 Computing Element.

Second Edition (October, 1971)

This is a major revision of, and obsoletes SFN-0205-0.

This manual has been prepared by IBM Product Publications, Kingston, N.Y.

©Copyright International Business Machines Corporation 1970, 1971

Visual Index	v	33	3 Volt at 40 AMP Magnetic Amplifier Assembly	64
How To Use This Parts Catalog	vi	34	6 Volt DC at 40 AMP MC Power Supply Assembly	66
Catalog Section	1	35	Fan Assembly	68
Fig No.	Page	37	Power Frame Assembly - Frame 01, Sheet 1 of 2	70
1	2	37	Power Frame Assembly - Frame 01, Sheet 2 of 2	72
1	4	38	Relay Gate Housing Assembly	74
1	6	39	Right and Left Power Tub Assembly	76
4	8	39A	Fan Assembly	78
5	10	40	Remote O/V-O/C Terminal Board Assembly	79
6	12	41	Remote O/V-O/C Assembly	80
7	14	42	Remote O/V-O/C Assembly	81
8	15	43	48 Volt at 2 AMP Magnetic Amplifier Assembly	82
9	16	44	6 Volt at 25 AMP Magnetic Amplifier Assembly	84
	17	45	18 VDC at 11 AMP Power Supply Assembly	86
10	18	46	Power Box Assembly, Sheet 1 of 2	88
11	20	46	Power Box Assembly, Sheet 2 of 2	90
12	22	47	Line Filter Assembly	92
12	24	48	Right I/O Panel Assembly	94
13	26	49	Left I/O Panel Assembly	95
14	28	51	Wall Frame Assembly - 1 Battery - Frame 09	96
15	30	52	Bootstrap Supply Assembly	98
16	32	53	Power Sense and Battery Charger Assembly	100
17	34	54	Transformer Sub Assembly	102
17A	36	55	25 AMP Service Battery Package Assembly	104
17A	38	56	12 and 13 Battery Tray Assembly	106
18	40	57	Battery Package Assembly	108
22	42	59	Cable and Jumper Assembly Component Parts, Sheet 1 of 3	112
23	44	59	Cable and Jumper Assembly Component Parts, Sheet 2 of 3	114
24	46	59	Cable and Jumper Assembly Component Parts, Sheet 3 of 3	116
25	48			
26	50			
27	52			
28	54			
28	56			
29	58			
30	60			
31	62			
32	63			
			Numeric Index	X-1

Visual Index
7201-02 Computing Element

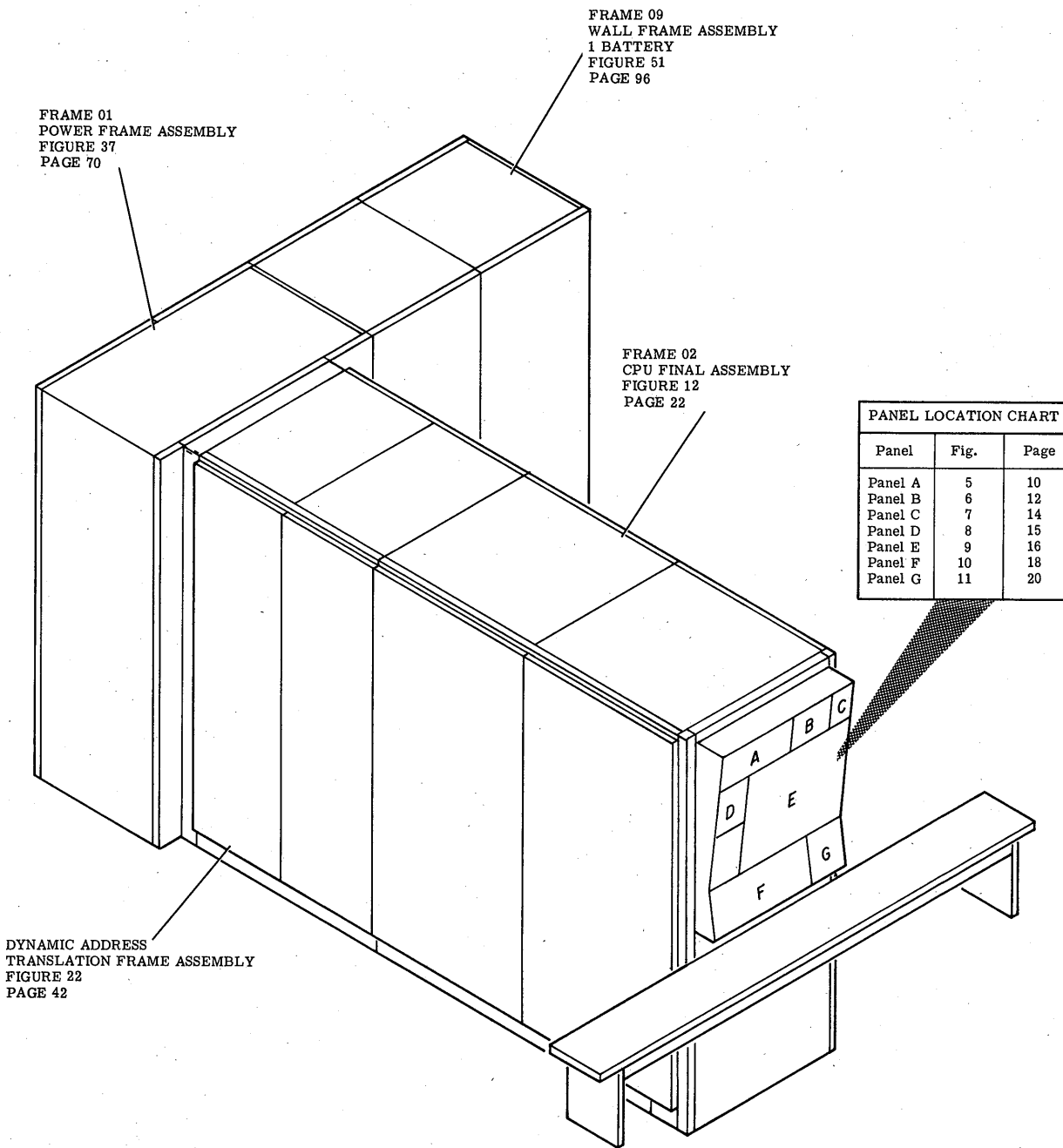

7201-02 COVERS AND PANELS
FIGURE 1
PAGE 2

CABLE ASSEMBLIES
LIST 58
PAGE 110

CABLE COMPONENT PARTS
FIGURE 59
PAGE 112

How To Use This Parts Catalog

CATALOG STRUCTURE

A general understanding of the structure of this catalog is necessary in order for the user to find parts easily and quickly. The catalog contains three major sections:

Visual Index - Contains overview illustrations of the machine with references into the Catalog Section.

Catalog Section - Contains exploded view drawings of assemblies and subassemblies of the machine with their associated Parts Lists.

Numerical Index - Lists all parts used in the machine with reference to the illustration (figure) on which the part is shown.

FINDING A PART

The Visual Index is the starting point to locate a part. The Visual Index illustrations are overall views of the machine. These illustrations will refer you to one of two places:

- (1) Another illustration in the Visual Index for finer detail of the portion of the machine in which you are interested and from there into a major assembly drawing in the Catalog Section, or
- (2) Directly into a major assembly drawing in the Catalog Section.

The major assembly drawing will either contain the desired part or it will reference a subordinate drawing; e.g., "See Figure 2 for detailed breakdown." Referencing may be carried to several levels before the desired part is found on an illustration. Once the part is found on an illustration, the index number serves as the key between the illustration and its associated Parts List.

ILLUSTRATION METHODS

Stacked Index Numbers

Stacked index numbers are used when showing a part and its attaching hardware as a group. The sequence of a typical stack is shown at the right. Use of the vertical line to the left of the stacked numbers is optional.

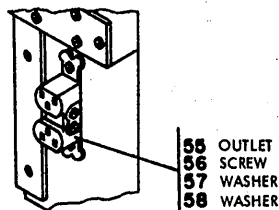

Circled Index Numbers

Circled index numbers indicate that the circled item is an assembly which is broken down within the figure. Two configurations are possible:

- (1) A circled index number with the index number of the end item of the assembly shown below the circled number.
- (2) A circled index number with attaching hardware stacked and with the end item of the assembly shown as the last index number in the stack.

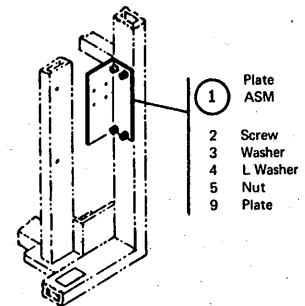
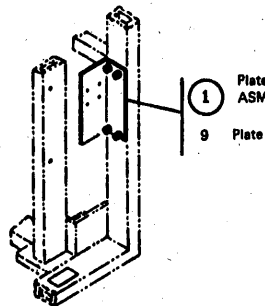

Reference Notes

Illustration notes that reference the next higher assembly are generally located in the upper left corner of the figure; e.g., "For Parts Not Shown, See Figure X." Illustration notes that reference a subassembly are located next to the index number; e.g., "See Figure Y."

Detail Boxes

A single-lined detail box is used to show either another view of an illustrated assembly or a finer breakdown of a portion of the illustrated assembly. The examples at the right are the symbols used to relate the content of the detail box to the assembly.

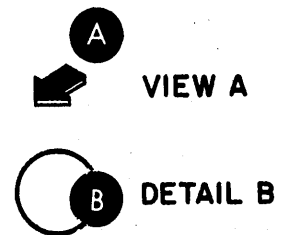

A double-lined detail box is used to show a different manufacturing level of a portion of the illustrated assembly. An explanation of the difference between these levels is contained within the box.

PARTS LIST NOMENCLATURE AND METHODS

The following terms are used throughout the Parts Lists; therefore, complete familiarity with them is essential. The terms are keyed to the sample parts list shown below.

- 1 AR (As Required) - denotes an undefined or an unknown quantity.
- 2 ATT PT (Attaching Parts) - denotes parts used to attach a part or subassembly to an assembly. The "attaching parts" are listed immediately following the part or subassembly to be attached and have the same indent level as the part or subassembly.
- 3 COMM (Commercial) - denotes hardware procurable from normal commercial sources and not identified by an IBM part number.
- 4 Indent pattern - indicates relationship of a part to its next higher assembly. For example:
 1 2 3 4
 Unit
 . Assemblies and Detail Parts of Unit
 . Attaching Parts for Assemblies & Detail Parts
 . . Subassemblies
 . . Attaching Parts for Subassemblies
 . . . Detail Parts for Subassemblies, etc.
- 5 NR (Not Recommended) - denotes the part is not recommended for field replacement, and that the next higher assembly should be ordered.
- 6 NP (Non-Procurable) - denotes the assembly is non-procurable and that detail parts must be ordered separately.
- 7 NO NO. (No Number) - denotes a group of parts for which no assembly part number has been assigned and that detail parts must be ordered separately.
- 8 REF (Reference) - denotes that quantities for such items are identified in the next higher assembly.
- 9 Similar Assemblies - If two assemblies contain a majority of identical parts, they are broken down on the same figure/list. Parts unique to either of the similar assemblies are identified by either a Usable On Code or a note in the description column.
- 10 Usable on Code - This column can be used to identify unique parts of similar assemblies (see 9 above). Two types of codes (an alphabetic and numeric) are used. For any given Parts List, the codes are defined at the top of that list and are only meaningful for that list.
 Alphabetic codes are used to identify unique parts of selective assemblies:
 Ex. 1 Code A - Used on 50-Hz machines.
 Code B - Used on 60-Hz machines.
 Ex. 2 Code A - Used on Red Cover Group.
 Code B - Used on Blue Cover Group.
 Code C - Used on Yellow Cover Group.
 Numeric codes are used to identify unique parts of different manufacturing levels of assemblies:
 Ex. 1 Code 1 - Used prior to suffix L7. (See 11 below.)
 Code 2 - Used after suffix L7.
 Ex. 2 Code 1 - Used prior to serial #10137.
 Code 2 - Used after serial #10137.
- 11 Suffix Code - indicates the month (alphabetic) and the year (numeric) of the engineering change; e.g., B 6 stamped after the serial number equals Feb 1966.

LIST AND INDEX NUMBER	PART NUMBER	DESCRIPTION	UNITS PER ASM.	USABLE ON CODE
		1 2 3 4		
		DRIVE MOTOR ASSEMBLY - 220 VOLTS		
2 -		CODE A USED ON 60 HZ ONLY CODE B USED ON 50 HZ ONLY CODE 1 USED ON ASM PRIOR TO B6 SUFFIX		
-	2199376 NP	DRIVE MOTOR ASM - 220 VOLTS 60 HZ	REF	1A
-	2199386 NP	DRIVE MOTOR ASM - 220 VOLTS 50 HZ	REF	1B
		FOR NEXT HIGHER ASM SEE FIGURE 1-92 FOR ILLUSTRATION SEE FIGURE 2		
- 1	2204176	. PULLEY, 60 HZ	1	A
- 1	2199255	. PULLEY, 50 HZ	1	B
- 2	79842	. SETSCREW, SPLINE DR CUP PT 8-32 X 3/8 LG	AR	
- 3	2204116	. MOTOR ASM, 220V AC 60 HZ	1	A
- 4	NO NO.	. MOTOR ASM, 220V AC 50 HZ	1	B
- 5	5526	. SCREW, MACH BIND HD 8-32 X 0.625 LG	4	
- 6	2204082	. FERRULE, OUTER	1	
- 7	2204033	. FERRULE, INNER	1	
- 8	COMM	. MOTOR, 1/12 HP - 220V 60 HZ	1	A
- 8	2199258	. MOTOR, 1/12 HP - 220V 50 HZ	1	B
- 9	2199401 NR	. PLATE, MOTOR MT - 220 VOLTS 60 HZ	1	A
- 9	2199402 NR	. PLATE, MOTOR MT - 220 VOLTS 50 HZ	1	B

CATALOG SECTION

www.ibm360.info

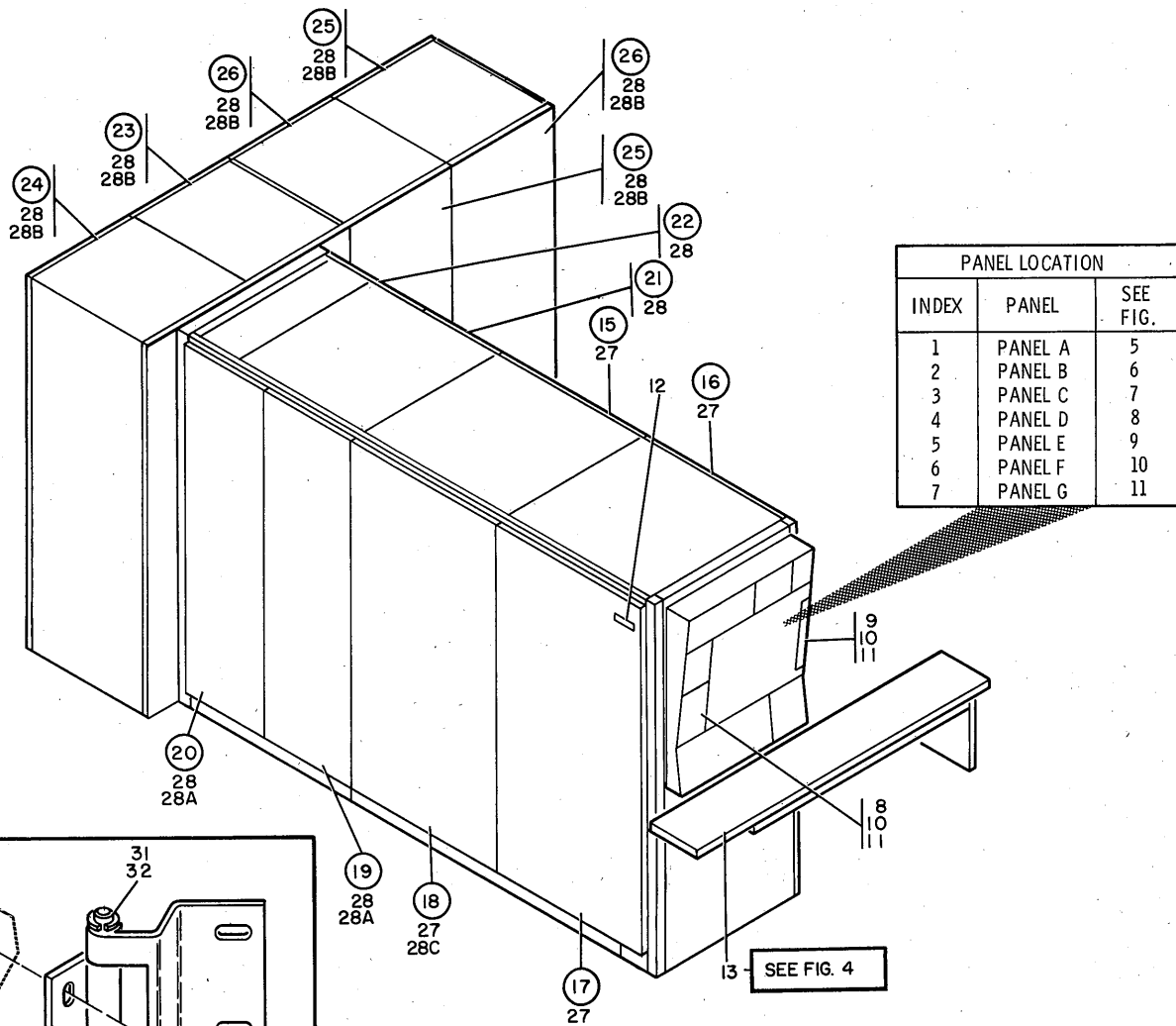

PANEL LOCATION		
INDEX	PANEL	SEE FIG.
1	PANEL A	5
2	PANEL B	6
3	PANEL C	7
4	PANEL D	8
5	PANEL E	9
6	PANEL F	10
7	PANEL G	11

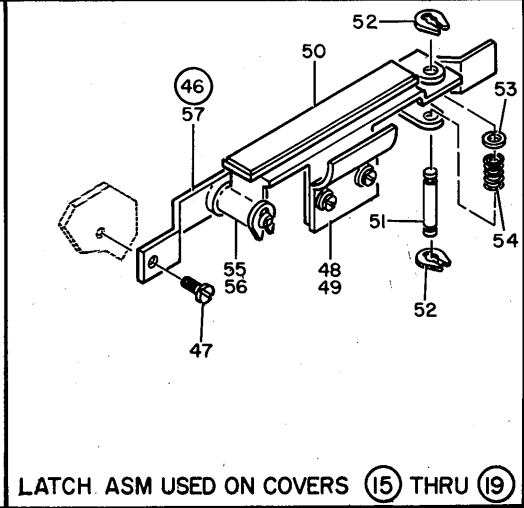
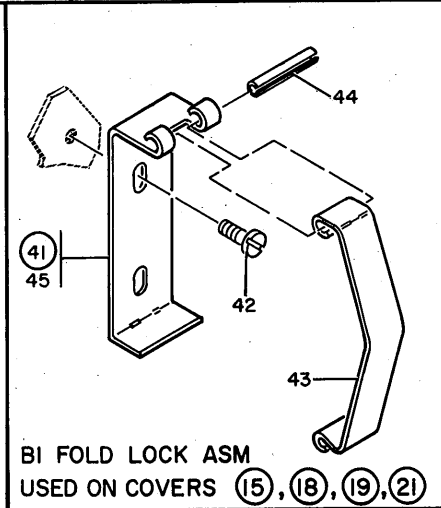
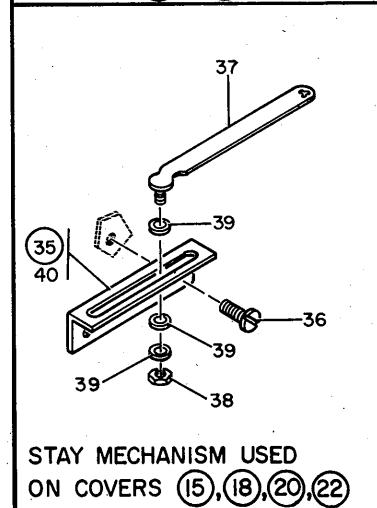
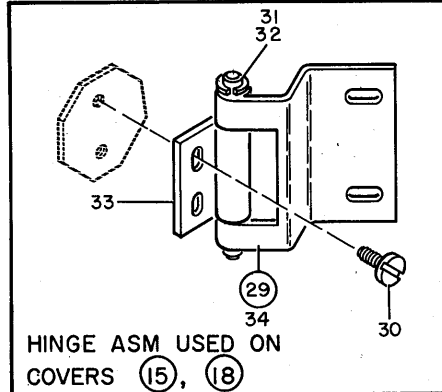

FIGURE 1. 7201-02 COVERS AND PANELS (SHEET 1 OF 3. INDEX NOS. 1-57)

LIST 1. 7201-02 COVERS AND PANELS

FIGURE- INDEX NUMBER	PART NUMBER	DESCRIPTION	UNITS PER ASM.	USABLE ON CODE
		1 2 3 4		
1 -	NO NO. NP	7201-02 COVERS AND PANELS		
- 1	5781320	. PANEL A ASSEMBLY CE CONSOLE FOR DETAIL BREAKDOWN SEE FIGURE 5	1	
- 2	5781321	. PANEL B ASSEMBLY CE CONSOLE FOR DETAIL BREAKDOWN SEE FIGURE 6	1	
- 3	5781322	. PANEL C ASSEMBLY CE CONSOLE FOR DETAIL BREAKDOWN SEE FIGURE 7	1	
- 4	5781323	. PANEL D ASSEMBLY CE CONSOLE FOR DETAIL BREAKDOWN SEE FIGURE 8	1	
- 5	5781324	. PANEL E ASSEMBLY CE CONSOLE FOR DETAIL BREAKDOWN SEE FIGURE 9	1	
- 6	5781325	. PANEL F ASSEMBLY CE CONSOLE FOR DETAIL BREAKDOWN SEE FIGURE 10	1	
- 7	5781326	. PANEL G ASSEMBLY CE CONSOLE FOR DETAIL BREAKDOWN SEE FIGURE 11	1	
- 8	5781832	. PANEL-BLANK	1	
- 9	5781807	. ROLLER PLATE-NOMENCLATURE	1	
- 10	257189	. NUT,HEX- 8-32 ATT PT	41	
- 11	55901	. WASHER,LOCK-EXT TEETH NO. 8 X 0.381 OD ATT PT	41	
- 12	5781456	. NAMEPLATE	1	
- 13	5373130	. CONSOLE TABLE,RH	1	
- 13	5373131	. CONSOLE TABLE,LH	1	
- 15	5781890	. COVER ASM,BLUE-RH FOR DETAIL BREAKDOWN SEE FIGURE 4	1	
- 15	5782243	. COVER-BLUE-RH	1	
- 16	5781524	. COVER ASM-BLUE	1	
- 16	5781522	. COVER-BLUE	1	
- 17	5400515	. COVER ASM-LH	1	
- 17	5403698	. COVER BLUE LH	1	
- 18	5397714	. COVER ASM BLUE LH	1	
- 18	5403686	. COVER BLUE LH	1	
- 19	5782263	. COVER ASM-SOLID,BI-FOLD-BLUE	1	
- 19	5726173	. LEFT FRONT COVER-BLUE	1	
- 20	5726185	. LEFT REAR LOGIC COVER ASSEMBLY-BLUE	1	
- 20	5726169	. LEFT REAR COVER-BLUE	1	
- 21	5726193	. RIGHT FRONT LOGIC COVER ASSEMBLY-BLUE	1	
- 21	5726177	. RIGHT FRONT COVER-BLUE	1	
- 22	5726181	. RIGHT REAR LOGIC COVER ASSEMBLY-BLUE	1	
- 22	5726165	. RIGHT REAR COVER-BLUE	1	
- 23	5723744	. COVER ASSEMBLY, VENTED LH	1	
- 23	5373001	. COVER,VENTED,HINGED,LH	1	
- 24	5723745	. COVER ASSEMBLY, VENTED RH	1	
- 24	5373000	. COVER,VENTED,HINGED,RH	1	
- 25	5403741	. COVER ASSEMBLY,REAR,LH	2	
- 25	5373001	. COVER,VENTED,HINGED,LH	1	
- 26	5403742	. COVER ASSEMBLY,REAR,HINGED	2	
- 26	5373000	. COVER,VENTED,HINGED,RH	1	
- 27	5372858	. SCREW,HEX HD 10-32 X .50 LG ATT PT	12	
- 28	332620	. SCREW,MACH-BIND HD 10-32 X 1/2 LG ATT PT	60	
- 28A	5407422	. SCREW,SHOULDER 10- 32 X .020 OD ATT PT	1	
- 28B	34512	. SCREW,BIND.HD 8-32 X .375 LG ATT PT	4	
- 28C	5407422	. SCREW,THD CUTTING-HEX HD 8-32 X 0.375 LG ATT PT	AR	
- 29	5397716	. HINGE ASM-COVER	AR	
- 30	32617	. SCREW,MACH-BIND HD 10-32 X 0.438 LG ATT PT	AR	
- 31	5372760	. PIN-HINGE	AR	
- 32	264641	. RING,RETAINING-EXT 0.114 ID X 0.025 THK ATT PT	AR	
- 33	5372855	. HINGE-DOOR	AR	
- 34	5372877	. HINGE,COVER	AR	
- 35	5418258	. STAY MECHANISM ASSEMBLY-RIGHT HAND	AR	
- 35	2418257	. STAY MECHANISM ASM-LEFT HAND	AR	
- 36	34512	. SCREW,BIND.HD 8-32 X .375 LG ATT PT	AR	
- 36	186758	. SCREW,MACH-BIND HD 8-32 X 0.438 ATT PT	AR	
- 37	5407557	. STAY ARM ASSEMBLY-R.H.	AR	
- 37	5407558	. STAY ARM ASSEMBLY-L.H.	AR	
- 38	72828	. NUT,SELF LKG,HEX- 8-32 X 0.334 FL W ATT PT	AR	
- 39	2561419	. WASHER ATT PT	AR	
- 40	5407559	. BRACKET ASSEMBLY,GUIDE-STAY MECHANISM	AR	
- 41	5372895	. LOCK ASM	AR	
- 42	34512	. SCREW,BIND.HD 8-32 X .375 LG ATT PT	AR	
- 43	5372893	. CLIP	AR	
- 44	311462	. PIN,SPRING- 0.133 X 0.750 LG ATT PT	AR	
- 45	5372894	. BRACKET	AR	

LIST 1. 7201-02 COVERS AND PANELS

FIGURE- INDEX NUMBER	PART NUMBER	DESCRIPTION	UNITS PER ASM.	USABLE ON CODE
		1 2 3 4		
1 -	46	5372775		
- 47	34512	. LATCH ASSEMBLY	AR	
- 48	5397691	. SCREW,BIND.HD 8-32 X .375 LG ATT PT	AR	
- 49	58207	. CLAMP	AR	
- 50	5407569	. SCREW,MACH-UNDRCT BIND HD 8-32 X 1/4 LG ATT PT	AR	
- 51	5372780	. PLATE	AR	
- 52	257701	. PIN-SPRING GUIDE	AR	
- 53	5312547	. RETAINER-PIVOT PIN ATT PT	AR	
- 54	223227	. SPACER,PIN,STAY ARM	AR	
- 55	5372779	. SPRING,COMPRESSION	AR	
- 56	1092125	. HANDLE-ACTUATOR ATT PT	AR	
- 57	5372781	. RING-RETAINING	AR	
		. BRACKET-LATCH PIVOT MOUNTING	AR	

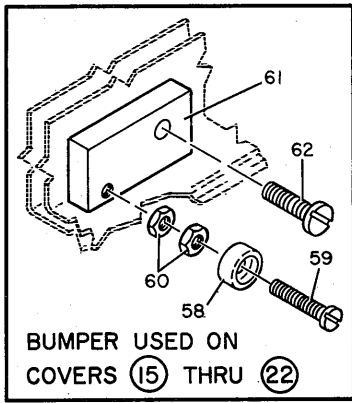

FOR COVER
PART NUMBERS,
SEE SHEET 1

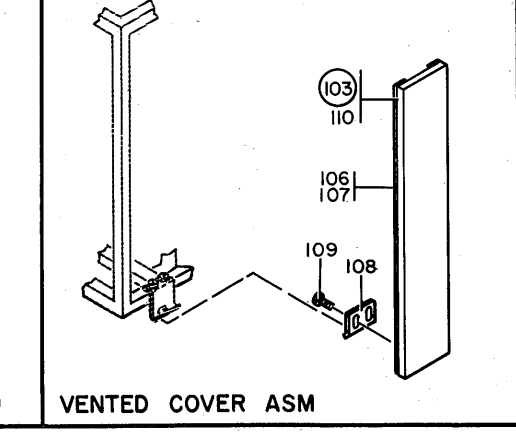
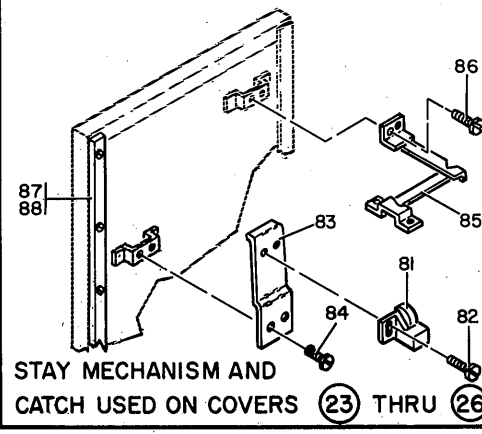
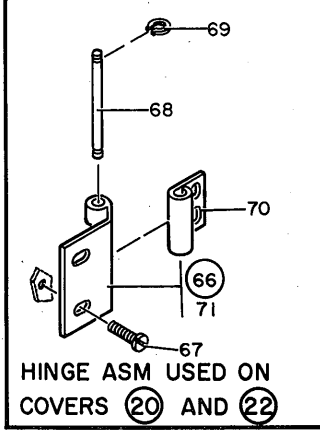
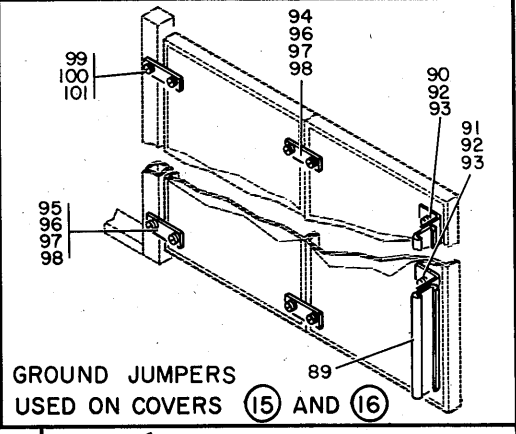
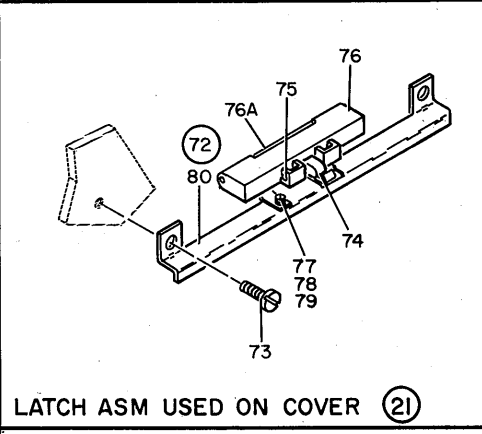
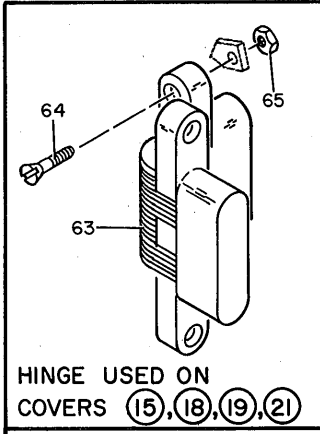
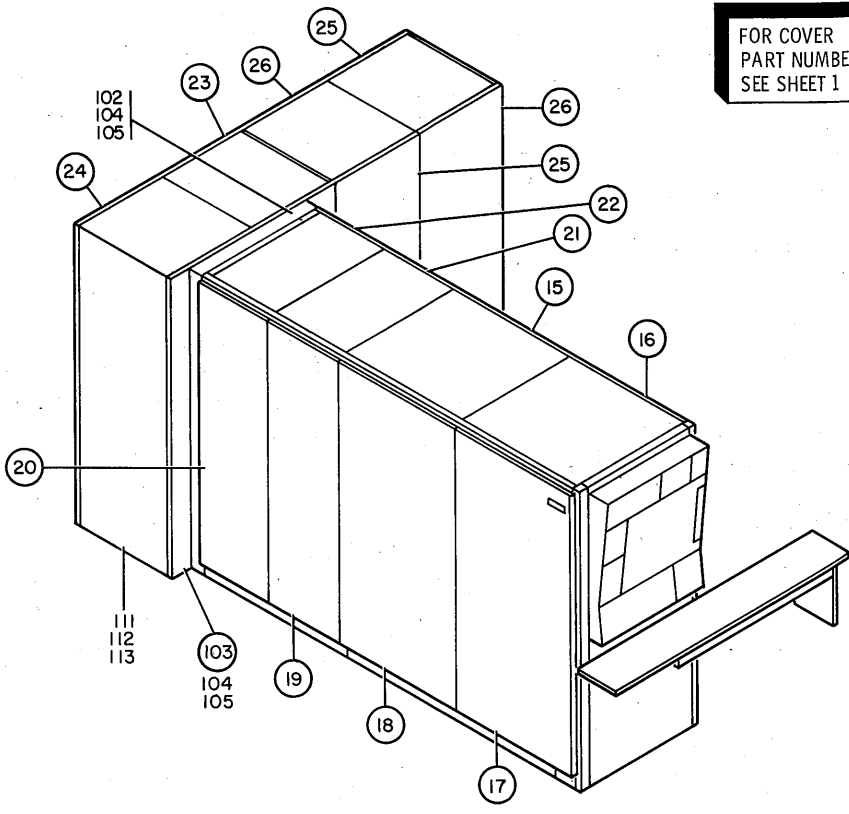

FIGURE 1. 7201-02 COVERS AND PANELS (SHEET 2 OF 3. INDEX NOS. 58-113)

LIST 1. 7201-02 COVERS AND PANELS

FIGURE- INDEX NUMBER	PART NUMBER	1 2 3 4	DESCRIPTION	UNITS PER ASM.	USABLE ON CODE
1 - 58	597671		• BUMPER		
- 59	510379		• SCREW	AR	
- 59	5644		• SCREW,MACH-FIL H 6-32 X 5/8 LG	AR	
- 59	322065		• SCREW,MACH-BIND HD 6-32 X 5/8 LG	AR	
- 60	257187		• NUT,PLAIN,HEX- 6-32 X 3/8 FL W	AR	
- 61	5373035		• BASE-BUMPER	AR	
- 62	5528		• SCREW,MACH BIND HD 8-32 X .625 LG	AR	
- 63	5373003		• HINGE	AR	
- 64	367		• SCREW,MACH-FL CSK HD 10-32 X 5/8 LG	AR	
- 65	125930		• NUT-STOP, ELASTIC HEX 10-32	AR	
- 66	5397740		• HINGE ASSEMBLY	AR	
- 67	32617		• SCREW,MACH-BIND HD 10-32 X 0.438 LG	AR	
- 68	5372760		• • PIN-HINGE	AR	
- 69	264641		• RING,RETAINING-EXT 0.114 ID X 0.025 THK	AR	
- 70	5372855		• • HINGE-DOOR	AR	
- 71	5372856		• • HINGE-DOOR	AR	
- 72	5420365		• LATCH ASM	AR	
- 73	34512		• SCREW,BIND.HD 8-32 X .375 LG	AR	
- 74	5420369		• • CATCH	AR	
- 75	5420372		• • PIN-CATCH	AR	
- 76	5420428		• • BODY,LATCH	AR	
- 76A	5420373		• • PIN,BODY	AR	
- 77	5420370		• • SPRING	AR	
- 78	48594		• • SCREW,MACH-BIND HD 6-32 X 0.250 LG	AR	
- 79	257984		• • WASHER,LOCK-SPLIT 1/8 ID X 13/64 OD	AR	
- 80	5420368		• • BRACKET	AR	
- 81	513668		• CATCH,FRICITION LATCH	AR	
- 82	55726		• SCREW,MACH-BIND HD 6-32 X .188 LG	AR	
- 83	5723746		• BRACKET-ADAPTER	AR	
- 84	10170		• SCREW,MACH-BIND HD 6-32 X 1/4 LG	AR	
- 85	5372922		• STAY MECHANISM ASM-LH	AR	
- 85	5372921		• MECHANISM ASSEMBLY,STAY-R.H.	AR	
- 86	58207		• SCREW,MACH-UNDRCT BIND HD 8-32 X 1/4 LG	AR	
- 87	5373048		• SEAL-VENTED COVER	AR	
- 88	58207		• SCREW,MACH-UNDRCT BIND HD 8-32 X 1/4 LG	AR	
- 89	2564585		• STRIP	AR	
- 90	5781521		• ANGLE BRACKET	1	
- 91	5781520		• ANGLE BRACKET	1	
- 92	5781528		• SCREW	11	
- 93	2566646		• WASHER,FL-NO. 8 X 0.375 OD X 0.032 THK	ATT PT	
- 94	5782297		• JUMPER,GROUND	4	
- 95	5782290		• STRAP,GROUNDING	4	
- 96	5781528		• SCREW	ATT PT	
- 97	2574804		• WASHER,LOCK-EXT TOOTH 0.168 ID	ATT PT	
- 98	2566646		• WASHER,FL-NO. 8 X 0.375 OD X 0.032 THK	ATT PT	
- 99	2575295		• SCREW,BND HD- 10-32 X .375 LG	ATT PT	
- 100	2574805		• WASHER,LOCK,EXT +- .195 ID	ATT PT	
- 101	2566647		• WASHER,FL-NO. 10 X 0.438 OD X 0.032 THK	ATT PT	
- 102	5372999		• COVER-VENTED	1	
- 103	5403830		• COVER ASSEMBLY,FIXED,RH	1	
- 104	34512		• SCREW,BIND.HD 8-32 X .375 LG	4	
- 105	22478		• WASHER,FL- 0.170 ID 0.375 OD 0.32 THK	ATT PT	
- 106	5373063		• • PLATE SEAL	2	
- 107	58207		• • SCREW,MACH-UNDRCT BIND HD 8-32 X 1/4 LG	ATT PT	
- 108	5373051		• • BRACKET-COVER	1	
- 109	58207		• • SCREW,MACH-UNDRCT BIND HD 8-32 X 1/4 LG	ATT PT	
- 110	5373015		• • COVER	2	
- 111	5373004		• COVER END	1	
- 112	34512		• SCREW,BIND.HD 8-32 X .375 LG	3	
- 113	22478		• WASHER,FL- 0.170 ID 0.375 OD 0.32 THK	ATT PT	
				12	

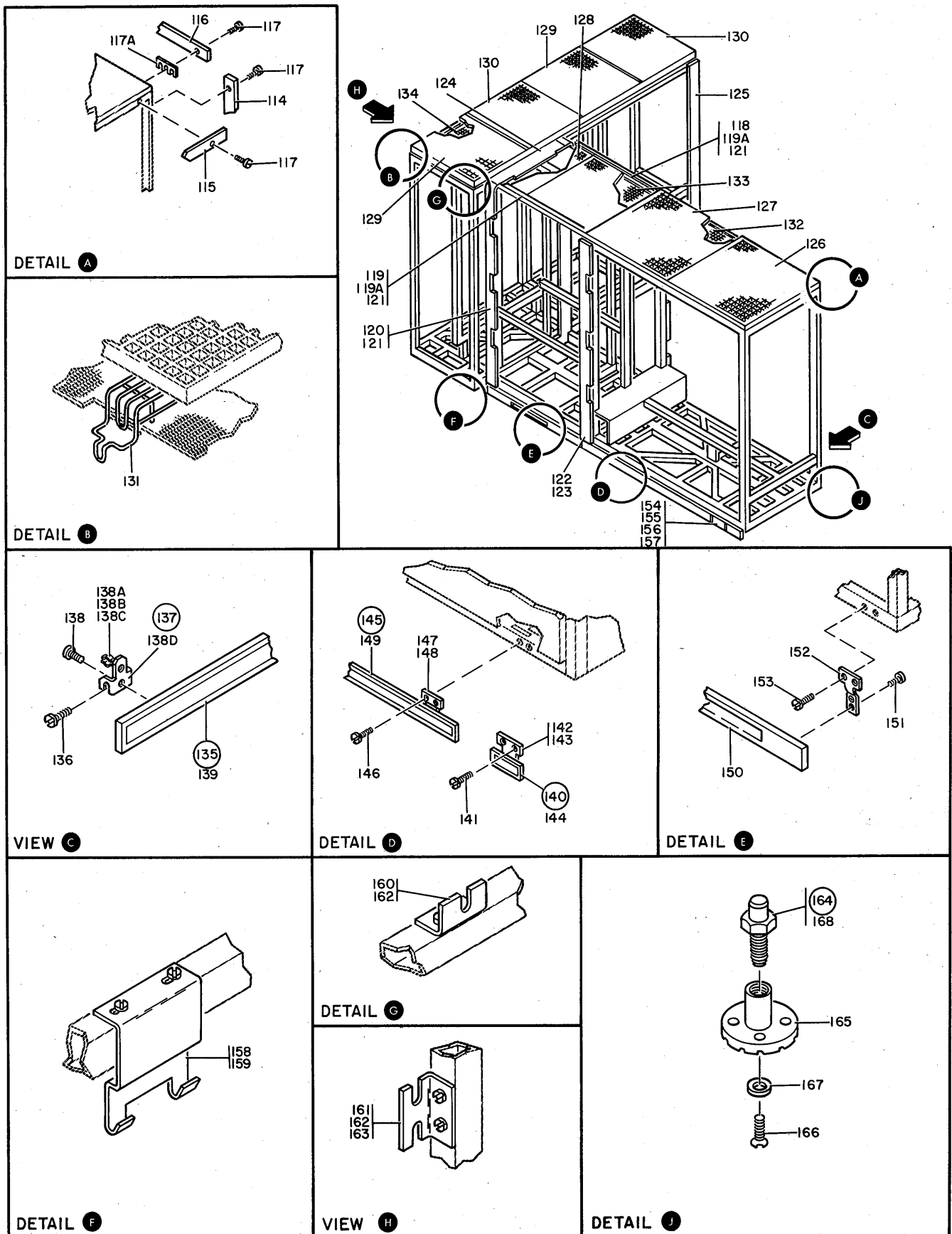

FIGURE 1. 7201-02 COVERS AND PANELS (SHEET 3 OF 3. INDEX NOS. 114-168)

LIST 1. 7201-02 COVERS AND PANELS

FIGURE- INDEX NUMBER	PART NUMBER	DESCRIPTION	UNITS PER ASM.	USABLE ON CODE
I -114	5393226	• TRIM	2	
-115	5372905	• TRIM-UPPER	1	
-116	5372866	• TRIM	2	
-117	731630	• SCREW, THD FORMING- 10-32 X 0.500 LG	ATT PT	23
-117A	5418186	• SHIM, SLOTTED- 1.0 X 1-3/4 X 1/32 THK		10
-118	5726138	• TRIM-UPPER		1
-119	5726020	• TRIM-UPPER RIGHT		1
-119A	5418186	• SHIM, SLOTTED- 1.0 X 1-3/4 X 1/32 THK		10
-120	5723657	• TRIM-CLOSURE L.H.		1
-120	5372987	• TRIM-CLOSURE RH		1
-121	332620	• SCREW, MACH-BIND HD 10-32 X 1/2 LG	ATT PT	16
-122	5726137	• TRIM-CLOSURE		2
-123	509772	• SCREW, MACH-BIND HD 10-32 X 7/16	ATT PT	16
-124	5372988	• TRIM-CLOSURE TOP		1
-125	5723817	• COVERPLATE		2
-126	5723600	• COVER-TOP FRAME		1
-127	5373180	• COVER		2
-128	5723199	• COVER-TOP FRAME		1
-129	5373178	• COVER, FRAME, 24X43		2
-130	5373179	• COVER		2
-131	5403786	• SUPPORT-GRID COVER		6
-132	5407424	• SCREEN		1
-133	5726154	• SCREEN-SSU		1
-134	5723819	• SCREEN		2
-135	5400448	• KICKPLATE ASSEMBLY		1
-136	731630	• SCREW, THD FORMING- 10-32 X 0.500 LG	ATT PT	4
-137	5372828	• BRACKET ASSEMBLY-KICKPLATE		2
-138	381741	• SCREW, THREAD FORM-PAN HD 8-32 X 3/8 LG	ATT PT	4
-138A	308789	• CLIP, SPRING TENSION-STYLUS HOLDER		1
-138B	38262	• SCREW, MACH-FIL H 4-40 X 1/4 LG	ATT PT	1
-138C	257984	• WASHER, LOCK-SPLIT 1/8 ID X 13/64 OD	ATT PT	1
-138D	5372829	• BRACKET-KICKPLATE		1
-139	5372831	• KICKPLATE, SIDE		1
-140	5782251	• KICKPLATE ASM-SHORT		1
-141	731630	• SCREW, THD FORMING- 10-32 X 0.500 LG	ATT PT	2
-142	5782245	• BRACKET		1
-143	381741	• SCREW, THREAD FORM-PAN HD 8-32 X 3/8 LG	ATT PT	4
-144	5782248	• PLATE		1
-145	5782250	• KICKPLATE ASM-LONG		1
-146	731630	• SCREW, THD FORMING- 10-32 X 0.500 LG	ATT PT	4
-147	5403879	• BRACKET KICKPLATE MTG		2
-148	381741	• SCREW, THREAD FORM-PAN HD 8-32 X 3/8 LG	ATT PT	4
-149	5782247	• PLATE		1
-150	5726134	• KICKPLATE-FRAME		2
-151	738378	• SCREW, THD FORMING, PAN HD, 8-32 X .250	ATT PT	8
-152	5403879	• BRACKET KICKPLATE MTG		4
-153	332620	• SCREW, MACH-BIND HD 10-32 X 1/2 LG	ATT PT	8
-154	5782246	• KICKPLATE-GATE SUPPORT		1
-155	3960	• NUT, PLAIN, HEX- 1/4-20 X 7/16 FL W	ATT PT	3
-156	3550	• WASHER, FL- 1/4 X 9/16 OD X 0.050 THK	ATT PT	3
-157	6935	• WASHER, LOCK-SPLIT 1/4 X 0.493 OD	ATT PT	3
-158	5373059	• BRACKET-COVER MTG		2
-159	34512	• SCREW, BIND. HD 8-32 X .375 LG	ATT PT	4
-160	5397883	• BRACKET		6
-161	5397884	• BRACKET, LOWER		6
-162	332620	• SCREW, MACH-BIND HD 10-32 X 1/2 LG	ATT PT	24
-163	5311086	• SCREW, SHOULDER, STOP, CARTRIDGE RETRACTION	ATT PT	6
-164	587875	• FOOT ASSEMBLY-LEVELING		8
-165	587874	• FOOT-ADJUSTABLE RUBBER BASE		1
-166	186036	• SCREW, MACH-FH 1/4-20 X 1/2 LG	ATT PT	1
-167	587866	• STOP-LEVELING FOOT	ATT PT	1
-168	587834	• STUD-LEVELING		1

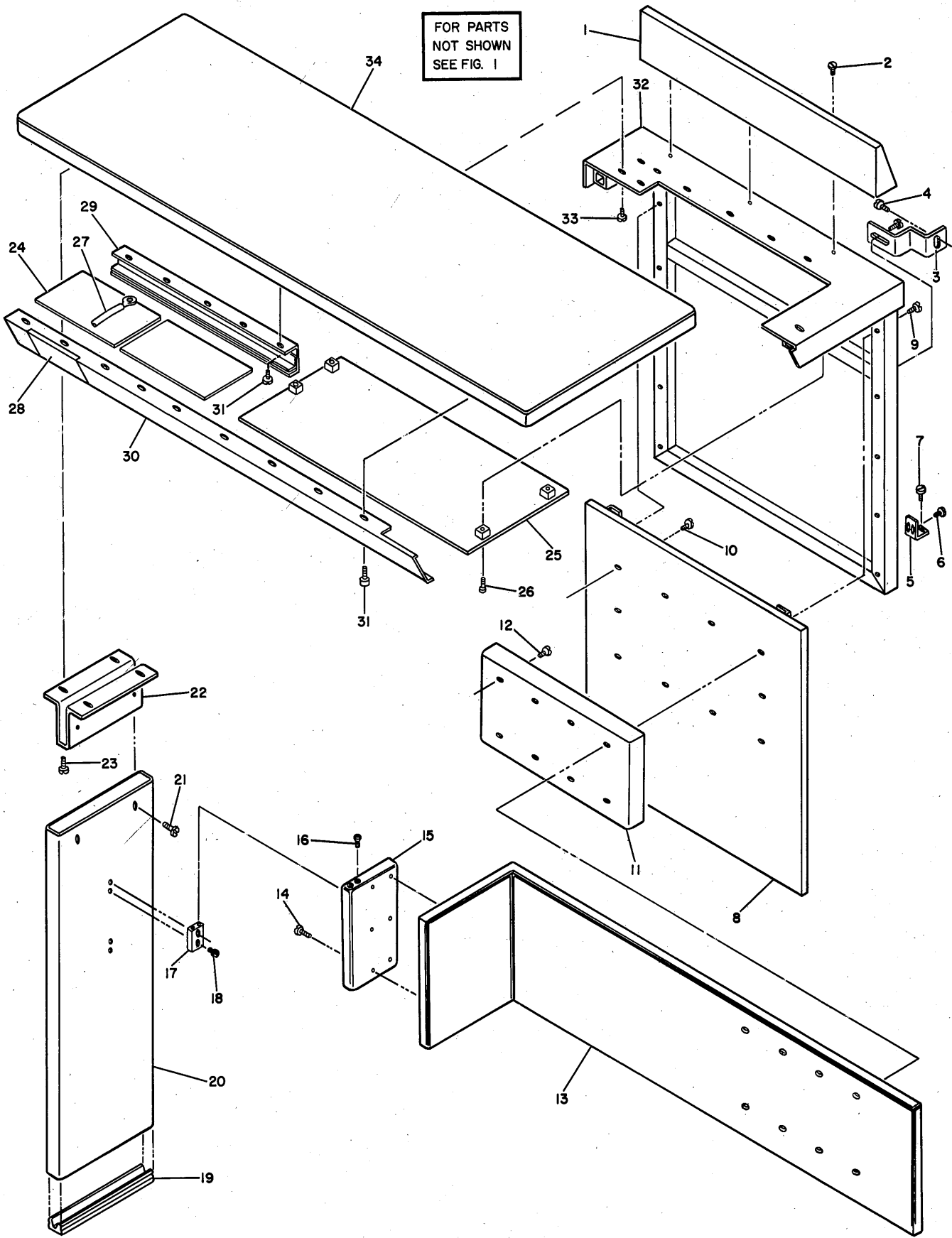

FIGURE 4. RH AND LH CONSOLE TABLE.

LIST 4. RH AND LH CONSOLE TABLE

FIGURE- INDEX NUMBER	PART NUMBER	DESCRIPTION	UNITS PER ASM.	USABLE ON CODE
4 -	5373130 NP	CONSOLE TABLE-RH		
-	5373131 NP	CONSOLE TABLE-LH		
		FOR NEXT HIGHER ASM,SEE FIG. 1-13		
- 1	5443261	• COVER,CONSOLE	1	
- 2	32042	• SCREW, MACH BIND. HD 10-32 X 3/8 LG. ATT PT	3	
- 3	5474732	• BRACKET-MTG	2	
- 4	32042	• SCREW, MACH BIND. HD 10-32 X 3/8 LG. ATT PT	4	
- 5	5373097	• BRACKET	2	
- 6	28413	• SCREW,MACH-BIND HD 10-32 X 5/16 LG ATT PT	4	
- 7	32042	• SCREW, MACH BIND. HD 10-32 X 3/8 LG. ATT PT	2	
- 8	5373128	• COVER-LOWER CONSOLE	1	
- 9	32042	• SCREW, MACH BIND. HD 10-32 X 3/8 LG. ATT PT	10	
- 10	601185	• SCREW,PAN HEAD- 10-16 X 1/2 LG	10	
- 11	5443252	• SPACER,FRONT	1	
- 12	83606	• SCREW,THD CTG-BIND HD 10-32 X 5/16 LG ATT PT	8	
- 13	5443265	• PANEL MODESTY-LH	1	
- 13	5443266	• PANEL MODESTY-RH	1	
- 14	83606	• SCREW,THD CTG-BIND HD 10-32 X 5/16 LG ATT PT	6	
- 15	5443262	• SPACER,SHORT END	1	
- 16	749089	• SCREW,MACH-FH CROSSTIE 10-32 X 1/2 LG ATT PT	4	
- 17	5349118	• BLOCK-MTG	2	
- 18	5677	• SCREW,MACH-BIND HD 10-32 X 3/4 LG ATT PT	4	
- 19	5349125	• GLIDE LEG	1	
- 20	5349116	• LEG-CONSOLE	1	
- 21	32042	• SCREW, MACH BIND. HD 10-32 X 3/8 LG.	2	
- 22	5349115	• BRACKET-MTG	1	
- 23	32042	• SCREW, MACH BIND. HD 10-32 X 3/8 LG. ATT PT	4	
- 24	5349152	• COVER,RACEWAY	2	
- 25	5443255	• COVER,RACEWAY-RH	1	
- 25	5443256	• COVER,RACEWAY-LH	1	
- 26	5677	• SCREW,MACH-BIND HD 10-32 X 3/4 LG ATT PT	4	
- 27	594234	• JUMPER ASSEMBLY FOR COMPONENT PARTS SEE FIG. 59-37A	AR	
- 28	5349174	• COVER-RAIL-RH	1	
- 28	5349195	• COVER-RAIL-LH	1	
- 29	5443254	• RAIL,COVER MOUNTING-RH	1	
- 29	5443253	• RAIL,COVER MOUNTING-LH	1	
- 30	5443264	• RAIL,RACEWAY COVER MOUNTING-RH	1	
- 30	5443263	• RAIL,RACEWAY COVER MOUNTING-LH	1	
- 31	32042	• SCREW, MACH BIND. HD 10-32 X 3/8 LG. ATT PT	14	
- 32	5373126	• FRAME-RH	1	
- 32	5373129	• FRAME-LH	1	
- 33	32042	• SCREW, MACH BIND. HD 10-32 X 3/8 LG. ATT PT	12	
- 34	5349114	• TABLE-TOP-RH	1	
- 34	5349192	• TABLE-TOP-LH	1	

FOR PARTS
NOT SHOWN
SEE FIG. 1

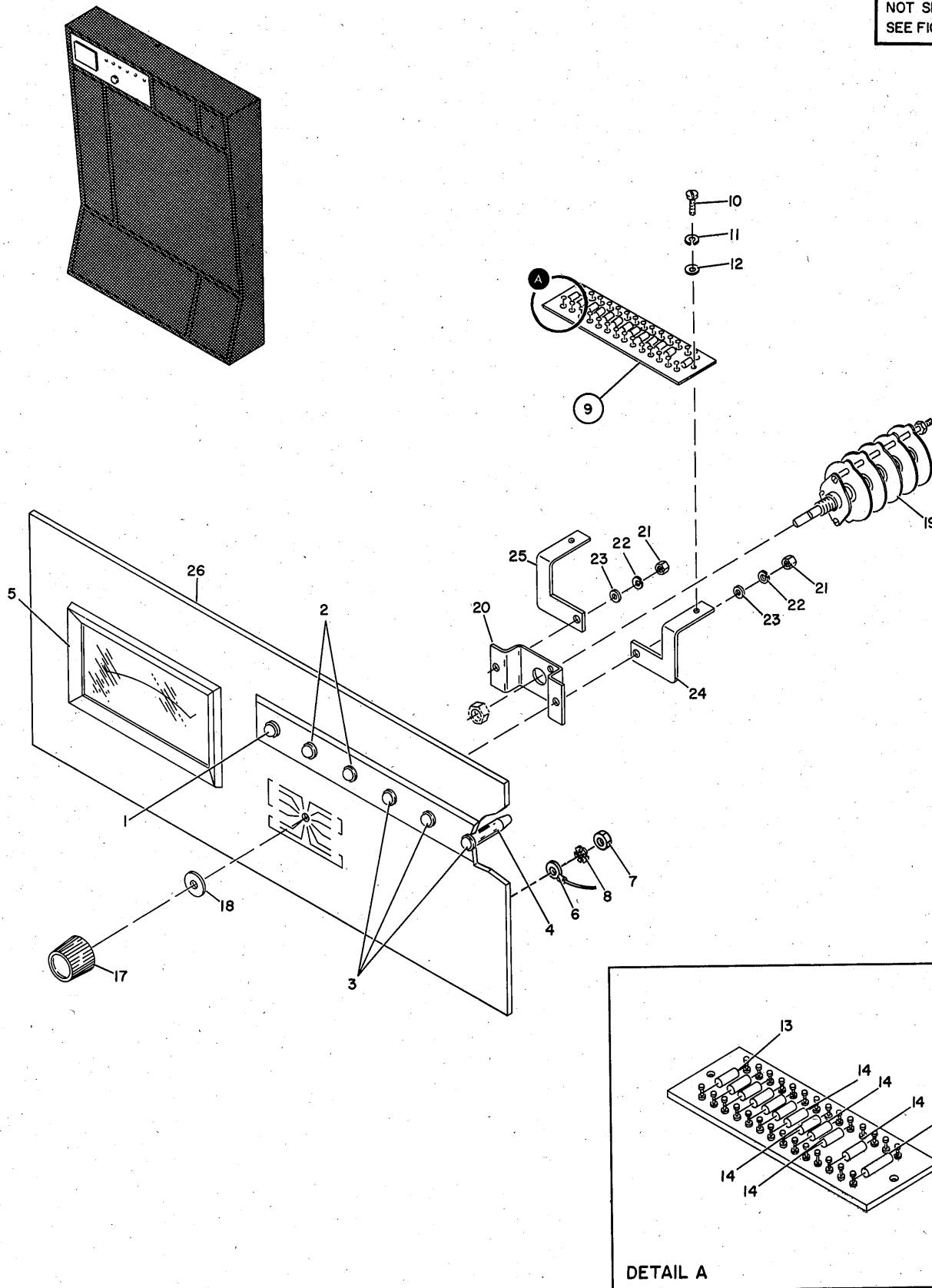
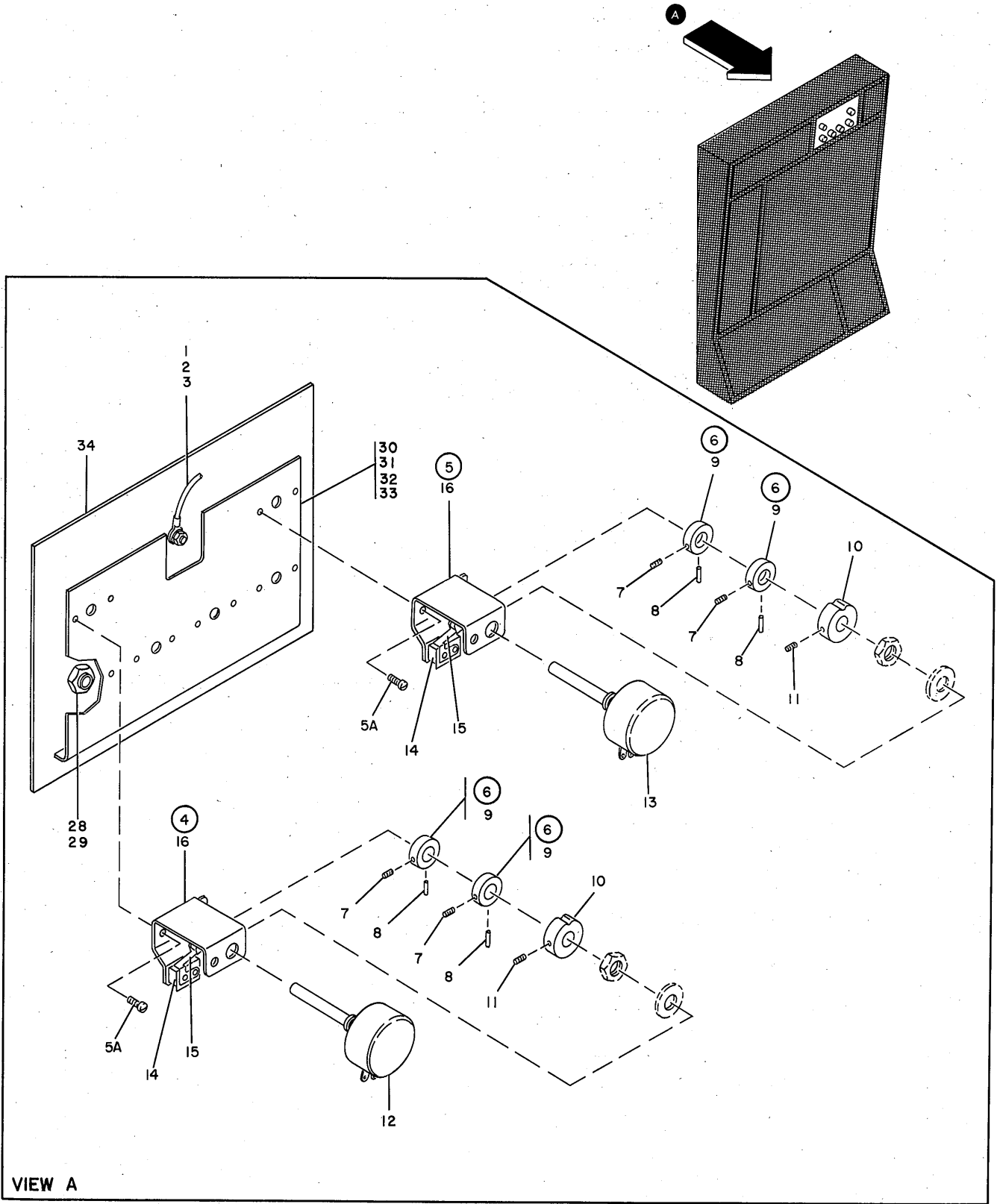

FIGURE 5. CE CONSOLE PANEL ASSEMBLY-A.

LIST 5. CE CONSOLE PANEL ASSEMBLY-A

FIGURE- INDEX NUMBER	PART NUMBER	DESCRIPTION				UNITS PER ASM.	USABLE ON CODE
		1	2	3	4		
5 -	5781320	PANEL A ASSEMBLY CE CONSOLE FOR NEXT HIGHER ASM,SEE FIG. 1-1				REF	
- 1	5353883	. INDICATOR ASM-AMBER-3 VOLT				1	
- 2	5353889	. INDICATOR ASM, CLEAR				2	
- 3	5353890	. INDICATOR ASM-RED-3 VOLT				3	
- 4	5353888	. HOUSING				6	
- 5	5276204	. VOLTMETER,0-10 DC				1	
- 6	5759582	. JUMPER ASM FOR COMPONENT PARTS SEE FIG. 59-36F				1	
- 7	257189	. NUT,HEX- 8-32				1	
- 8	55901	. WASHER,LOCK-EXT TEETH NO. 8 X 0.381 OD				1	
- 9	5781340	. RESISTOR BOARD ASM				1	
- 10	81693	. SCREW,MACH-BIND HD 6-32 X 3/8 LG				2	
- 11	6364	. WASHER,LOCK-SPLIT NO. 6 X 1/4 OD				2	
- 12	257986	. WASHER,FLAT NO. 6				2	
- 13	2111232	. . SEMICONDUCTOR DEVICE,DIODE-TYPE AM				6	
- 14	317429	. . RESISTOR,FXD,COMP- 1.3K P/M 5% 1/2W				5	
- 15	492425	. . RESISTOR				1	
- 16	5276366	. . TERMINAL BOARD-14 POSITION				1	
- 17	727454	. KNOB ASSEMBLY-MODE SWITCH				1	
- 18	5349203	. SPACER- 0.625 OD X 0.06 THK				1	
- 19	5214173	. SWITCH,ROTARY, 4 DECK 6 POSITION				1	
- 20	5781461	. BRACKET-SWITCH MTG				1	
- 21	257189	. NUT,HEX- 8-32				2	
- 22	1090873	. WASHER,LOCK,SPLIT RING- .168 ID, .296 OD				2	
- 23	22478	. WASHER,FL- 0.170 ID 0.375 OD 0.32 THK				2	
- 24	5276367	. BRACKET,TERMINAL BOARD,LEFT HAND				1	
- 25	5276368	. BRACKET,TERMINAL BOARD,RIGHT HAND				1	
- 26	5781366	. PANEL A-CE CONSOLE				1	

FOR PARTS
NOT SHOWN
SEE FIG. 1



VIEW A

FIGURE 6. CE CONSOLE PANEL ASSEMBLY-B.

LIST 6. CE CONSOLE PANEL ASSEMBLY-B

FIGURE-INDEX NUMBER	PART NUMBER	DESCRIPTION	UNITS PER ASM.	USABLE ON CODE
6 -	5781321	PANEL B ASSEMBLY CE CONSOLE	REF	
- 1	5759582	FOR NEXT HIGHER ASM,SEE FIG. 1-2 • JUMPER ASM	1	
		FOR COMPONENT PARTS SEE FIG. 59-36F		
- 2	257189	• NUT,HEX- 8-32	1	
- 3	55901	• WASHER,LOCK-EXT TEETH NO. 8 X 0.381 OD	1	
- 4	5781531	• DASHPOT ASM	1	
- 5	5781532	• DASHPOT ASM	5	
- 5A	58207	• SCREW,MACH-UNDRCT BIND HD 8-32 X 1/4 LG	12	
- 6	5737491	• • COLLAR ASSEMBLY	2	
- 7	257959	• • SETSCREW-SPLINE DR CUP PT 4-40 X 3/16 LG	2	
- 8	264998	• • • PIN,SPRING- 0.069 X 1/4 LG	1	
- 9	5753698	• • • COLLAR	1	
- 10	5276608	• • CAM,MARGINAL CHECK	1	
- 11	257959	• • SETSCREW-SPLINE DR CUP PT 4-40 X 3/16 LG	1	
- 12	5214624	• • RESISTOR,VARIABLE WIRE WOUND U/O ASM 5781531 ONLY	1	
- 13	5214623	• • RESISTOR,VARIABLE WIRE WOUND U/O ASM 5781532 ONLY	1	
- 14	808369	• • SWITCH,PRECISION-JAM DETECT	1	
- 15	5363960	• • ACTUATOR,SWITCH-INCLUDES HDWE AND INSUL	1	
- 16	5753697	• • BRACKET	1	
- 28	5383693	• INSERT-POT. ADJ	6	
- 29	518072	• NUT	6	
- 30	5781373	• BRACKET-POT MOUNTING	1	
- 31	257189	• NUT,HEX- 8-32	4	
- 32	1090873	• WASHER,LOCK,SPLIT RING- .168 ID, .296 OD	4	
- 33	22478	• WASHER,FL- 0.170 ID 0.375 OD 0.32 THK	4	
- 34	5781367	• PANEL B-CE CONSOLE	1	

FOR PARTS NOT SHOWN SEE FIG. 1

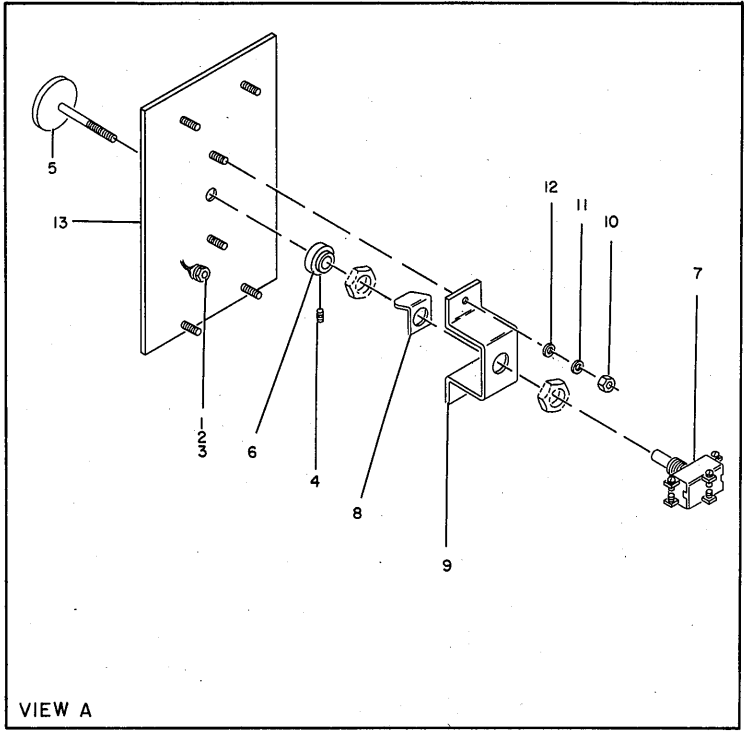
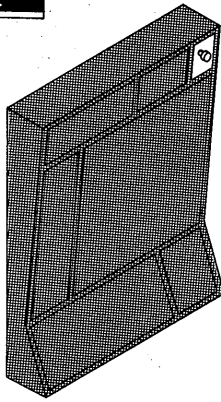
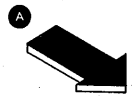

VIEW A

FIGURE 7. CE CONSOLE PANEL ASSEMBLY-C.

LIST 7. CE CONSOLE PANEL ASSEMBLY-C

FIGURE-INDEX NUMBER	PART NUMBER	DESCRIPTION	UNITS PER ASM.	USABLE ON CODE
7 -	5781322	PANEL C ASSEMBLY CE CONSOLE FOR NEXT HIGHER ASM, SEE FIG. 1-3	REF	
- 1	5759582	• JUMPER ASM	1	
- 2	257189	• NUT, HEX- 8-32	1	
- 3	55901	• WASHER, LOCK-EXT TEETH NO. 8 X 0.381 OD	1	
- 4	257965	• SETSCREW-SPLINE DR CUP PT 4-40 X 3/8 LG	1	
- 5	5383181	• KNOB ASSEMBLY-PULL	1	
- 6	482188	• COLLAR-PULL SWITCH DETENT	1	
- 7	482219	• SWITCH, PUSH PULL-DPDT	1	
- 8	479999	• SPRING, SAFETY	1	
- 9	5276231	• BRACKET, SWITCH	1	
- 10	257189	• NUT, HEX- 8-32	2	
- 11	1090873	• WASHER, LOCK, SPL IT RING- .168 ID, .296 OD	2	
- 12	22478	• WASHER, FL- 0.170 ID 0.375 OD 0.32 THK	2	
- 13	5781470	• PANEL C-CE CONSOLE	1	

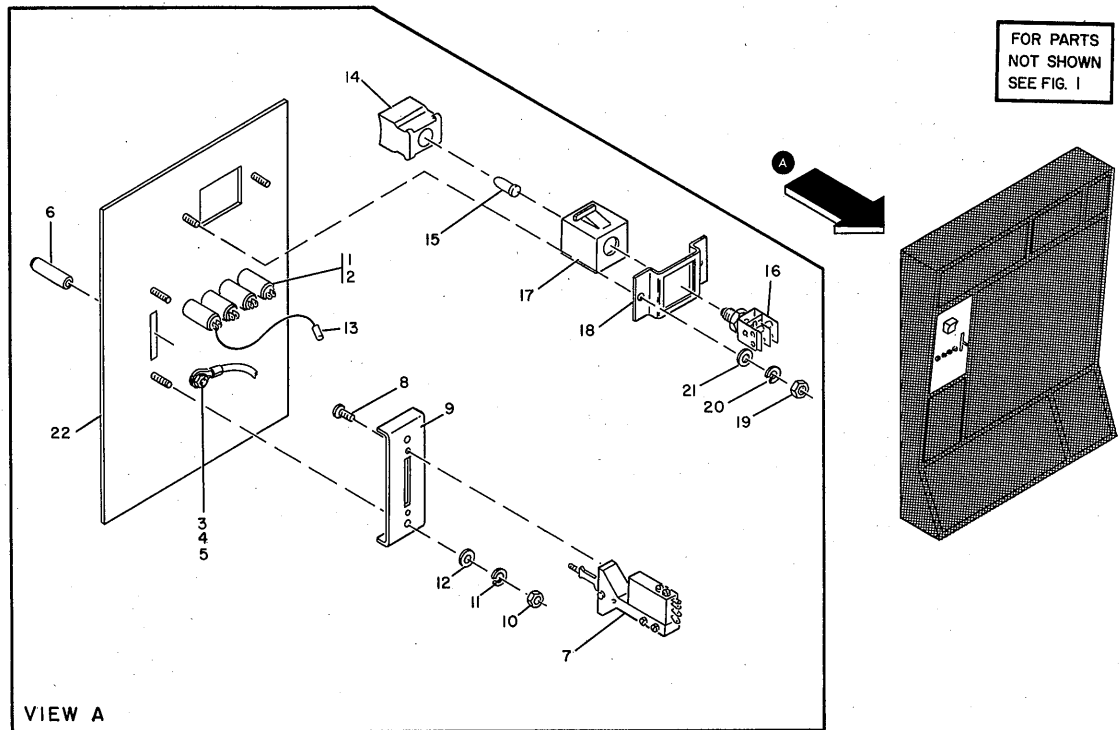
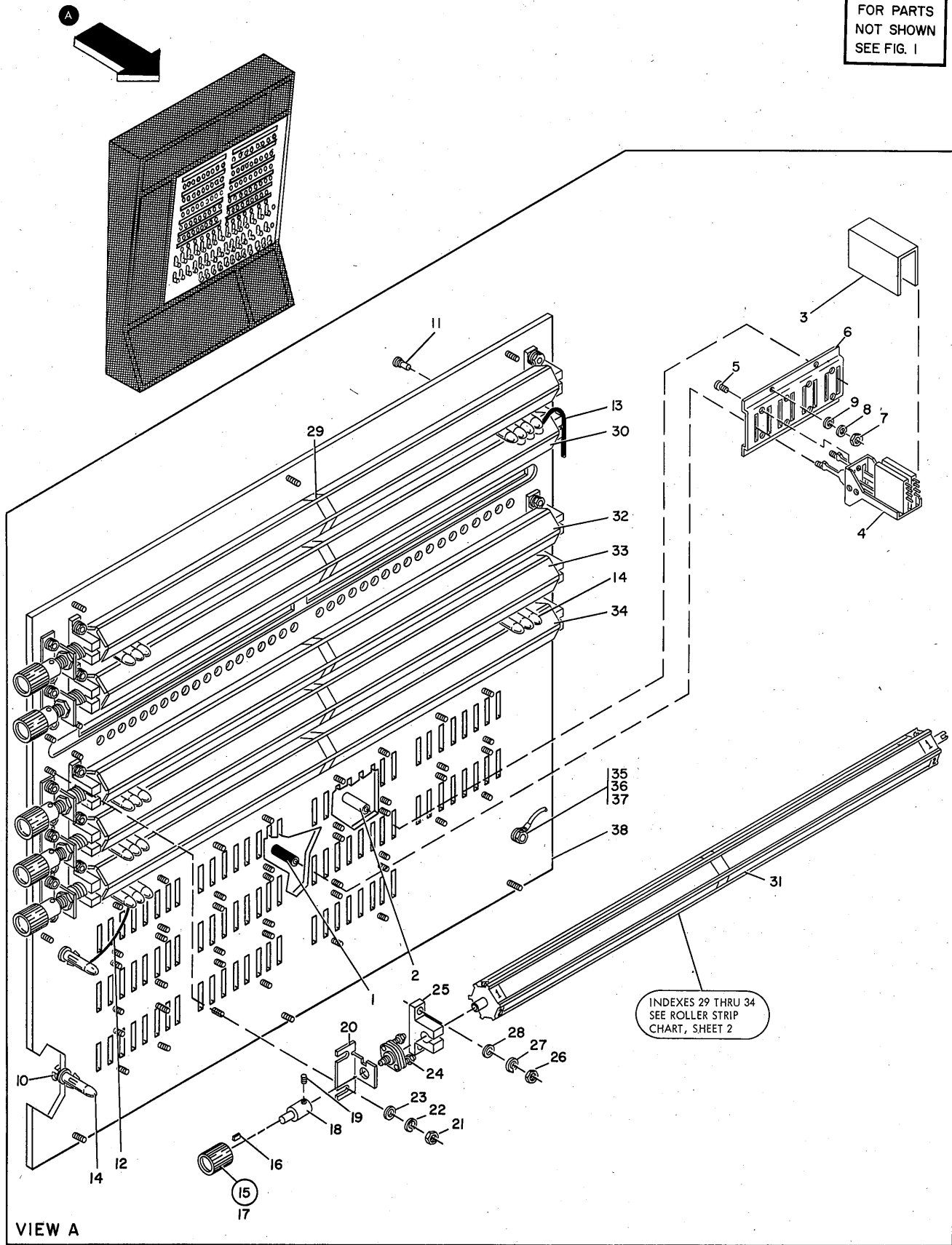

FIGURE 8. CE CONSOLE PANEL ASSEMBLY-D.

LIST 8. CE CONSOLE PANEL ASSEMBLY-D

FIGURE- INDEX NUMBER	PART NUMBER	DESCRIPTION	1 2 3 4				UNITS PER ASM.	USABLE ON CODE
8 -	5781323	PANEL D ASSEMBLY CE CONSOLE FOR NEXT HIGHER ASM, SEE FIG. 1-4					REF	
- 1	5353889	• INDICATOR ASM, CLEAR					4	
- 2	5353888	• HOUSING					4	
- 3	5759502	• JUMPER ASM FOR COMPONENT PARTS SEE FIG. 59-36F					1	
- 4	257189	• NUT, HEX- 8-32			ATT PT		1	
- 5	55901	• WASHER, LOCK-EXT TEETH NO. 8 X 0.381 OD			ATT PT		1	
- 6	5362315	• KNOB-WHITE					1	
- 7	5363964	• SWITCH, LEVER					1	
- 8	186712	• SCREW, MACH-BIND HD 3-48 X 3/16 LG			ATT PT		2	
- 9	5781375	• BRACKET-LEVER SWITCH					1	
- 10	257189	• NUT, HEX- 8-32			ATT PT		2	
- 11	1090873	• WASHER, LOCK, SPLIT RING- .168 ID, .296 OD			ATT PT		2	
- 12	22478	• WASHER, FL- 0.170 ID 0.375 OD 0.32 THK			ATT PT		2	
- 13	523176	• CONNECTOR, TWO WAY, WIRE SIZE 24-20					1	
- 14	5383203	• BUTTON					1	
- 15	369613	• LAMP, INCANDESCENT					2	
- 16	479309	• SWITCH, SENSITIVE- 2SPDT 250VAC- 5AMPS					1	
- 17	473629	• HOUSING-SWITCH AND LAMP					1	
- 18	5270142	• BRACKET-SWITCH					1	
- 19	257189	• NUT, HEX- 8-32			ATT PT		2	
- 20	1090873	• WASHER, LOCK, SPLIT RING- .168 ID, .296 OD			ATT PT		2	
- 21	22478	• WASHER, FL- 0.170 ID 0.375 OD 0.32 THK			ATT PT		2	
- 22	5781368	• PANEL D-CE CONSOLE					1	

FOR PARTS
NOT SHOWN
SEE FIG. 1



INDEXES 29 THRU 34
SEE ROLLER STRIP
CHART, SHEET 2

FIGURE 9. CE CONSOLE PANEL ASSEMBLY E. (SHEET 1 OF 2, INDEX NOS. 1-38)

LIST 9. CE CONSOLE PANEL ASSEMBLY E

7201 MODEL 02
ROLLER SWITCH INDICATOR PANEL "E"
ROLLER ASSEMBLIES AND DECALS

See Figure 9

Index No.	Roller No.	Position On Roller	Roller Part No.		Left Side	Right Side		
			Roller Part No.	Left Side				
29	1	1	5781471	5781760	5781764			
		2					5781761	5781765
		3					5732355	5732361
		4					5782284	5782285
		5					5781762	5781766
		6					5781763	5781767
30	2	1	5781472	5781768	5781773			
		2					5781769	5781774
		3					5732367	5732371
		4					5781770	5781809
		5					5781771	5781775
		6					5781772	5781815
31	3	1	5781473	5781776	5781780			
		2					5732374	5732379
		3					5732375	5732380
		4					5781777	5781814
		5					5781778	5781781
		6					5781779	5781782
32	4	1	5781474	5732383	5781785			
		2					5732384	5732389
		3					5732385	5732390
		4					5781783	5781786
		5					5732387	5781787
		6					5781784	5781788
33	5	1	5781475	5781789	5781794			
		2					5781790	5781795
		3					5732395	5732399
		4					5781791	5781796
		5					5781792	5781797
		6					5781793	5781798
34	6	1	5781476	5732401	5732405			
		2					5732402	5732406
		3					5781799	5781803
		4					5781800	5781804
		5					5781801	5781805
		6					5781802	5781806

FIGURE-INDEX NUMBER	PART NUMBER	DESCRIPTION				UNITS PER ASM.	USABLE ON CODE
		1	2	3	4		
9 -	5781324	PANEL E ASSEMBLY CE CONSOLE FOR NEXT HIGHER ASM, SEE FIG. 1-5				REF	
- 1	5362314	. KNOB-BLACK				4	
- 2	5362315	. KNOB-WHITE				4	
- 3	5419406	. DUST COVER				44	
- 4	5349003	. SWITCH, LEVER-3 POLE DT				44	
- 5	91373	. SCREW, MACH-BIND HD 3-48 X 0.250 LG				ATT PT	88
- 6	5276218	. BRACKET, LEVER SWITCH				ATT PT	11
- 7	257189	. NUT, HEX- 8-32				ATT PT	44
- 8	1090873	. WASHER, LOCK, SPLIT RING- .168 ID, .296 OD				ATT PT	44
- 9	22478	. WASHER, FL- 0.170 ID 0.375 OD 0.32 THK				ATT PT	44
- 10	5353890	. INDICATOR ASM-RED-3 VOLT				ATT PT	2
- 11	5353889	. INDICATOR ASM, CLEAR					216
- 12	5276348	. LEAD, ELECTRICAL FOR COMPONENT PARTS SEE FIG. 59-6					1
- 13	5276347	. LEAD, ELECTRICAL AND -10 FOR COMPONENT PARTS SEE FIG. 59-6					5
- 14	5353888	. HOUSING					218
- 15	482221	. KNOB ASSEMBLY, ROTARY					6
- 16	482195	. SPRING-CONTROL KNOB					1
- 17	482217	. KNOB ASSEMBLY, ROTARY					1
- 18	5276227	. ADAPTER, ROTARY SWITCH					6
- 19	257957	. SETSCREW-SPLINE DR CUP PT 4-40 X 1/8 LG				ATT PT	6
- 20	5276222	. BRACKET, SWITCH					6
- 21	257189	. NUT, HEX- 8-32				ATT PT	12
- 22	1090873	. WASHER, LOCK, SPLIT RING- .168 ID, .296 OD				ATT PT	12
- 23	22478	. WASHER, FL- 0.170 ID 0.375 OD 0.32 THK				ATT PT	12
- 24	5276216	. SWITCH, ROTARY					6
- 25	5276644	. BLOCK, ROLLER BEARING					12
- 26	257189	. NUT, HEX- 8-32				ATT PT	24
- 27	1090873	. WASHER, LOCK, SPLIT RING- .168 ID, .296 OD				ATT PT	24
- 28	22478	. WASHER, FL- 0.170 ID 0.375 OD 0.32 THK				ATT PT	24
- 29	5781471	. ROLLER ASM, FORMAT I					1
- 30	5781472	. ROLLER ASM, FORMAT II					1
- 31	5781473	. ROLLER ASM, FORMAT III					1
- 32	5781474	. ROLLER ASM, FORMAT IV					1
- 33	5781475	. ROLLER ASM, FORMAT V					1
- 34	5781476	. ROLLER ASM, FORMAT VI					1
- 35	5759502	. JUMPER ASM FOR COMPONENT PARTS SEE FIG. 59-36F					1
- 36	257189	. NUT, HEX- 8-32				ATT PT	1
- 37	55901	. WASHER, LOCK-EXT TEETH NO. 8 X 0.381 OD				ATT PT	1
- 38	5781369	. PANEL E-CE CONSOLE					1

FIGURE 9. CE CONSOLE PANEL ASSEMBLY E. (SHEET 2 OF 2. ROLLER STRIP CHART)

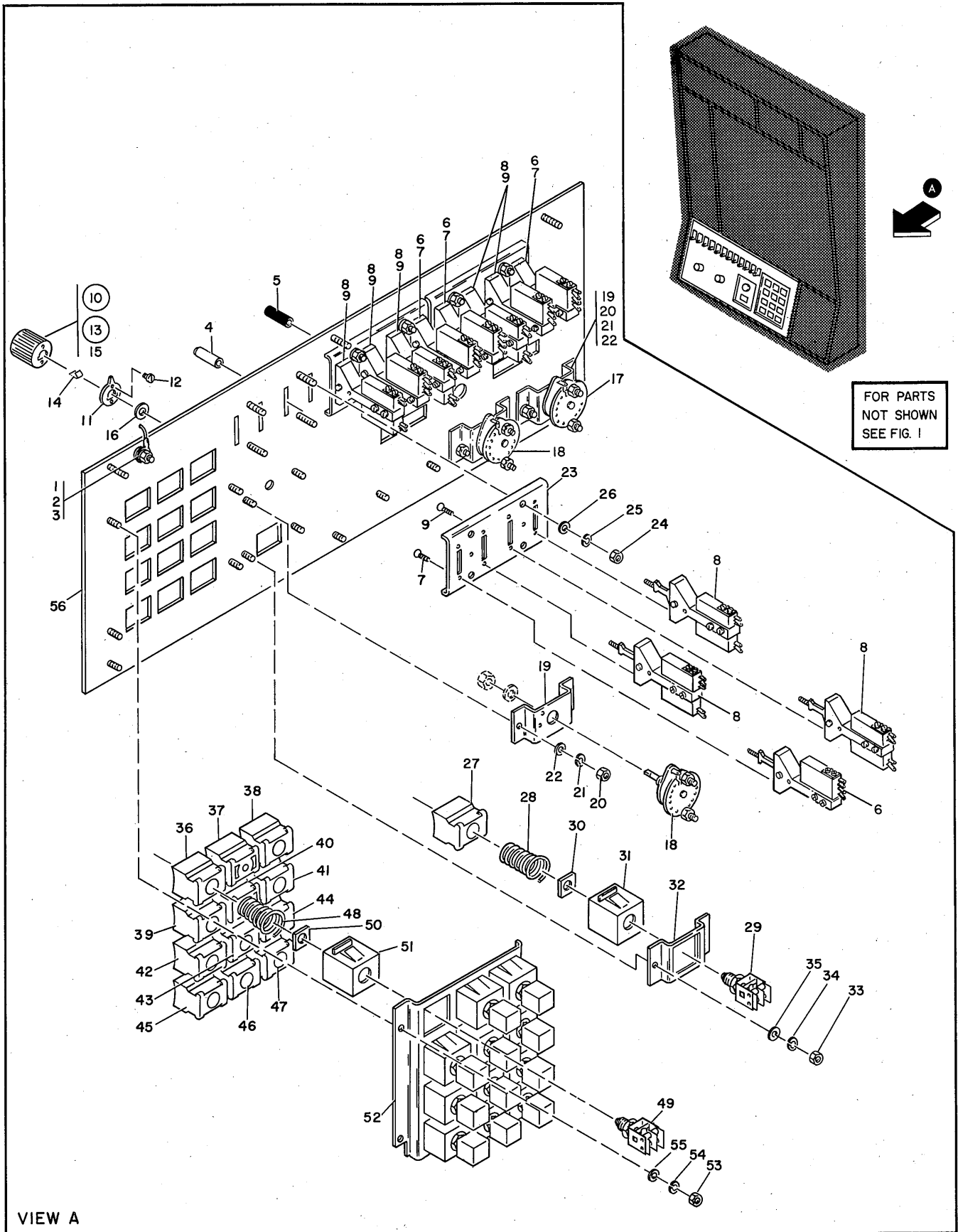

FIGURE 10. CE CONSOLE PANEL ASSEMBLY-F.

LIST 10. CE CONSOLE PANEL ASSEMBLY-F

FIGURE- INDEX NUMBER	PART NUMBER	DESCRIPTION	UNITS PER ASM.	USABLE ON CODE
10 -	5781325	PANEL F ASSEMBLY CE CONSOLE FOR NEXT HIGHER ASM,SEE FIG. 1-6	REF	
- 1	5759502	. JUMPER ASM	1	
		FOR COMPONENT PARTS SEE FIG. 59-36F		
- 2	257189	. NUT,HEX- 8-32	ATT PT	1
- 3	55901	. WASHER,LOCK-EXT TEETH NO. 8 X 0.381 OD	ATT PT	1
- 4	5362315	. KNOB-WHITE		9
- 5	5362314	. KNOB-BLACK		3
- 6	5349002	. SWITCH,LEVER		4
- 7	91373	. SCREW,MACH-BIND HD 3-48 X 0.250 LG	ATT PT	10
- 8	5276332	. SWITCH,LEVER		8
- 9	91373	. SCREW,MACH-BIND HD 3-48 X 0.250 LG	ATT PT	14
- 10	727454	. KNOB ASSEMBLY-MODE SWITCH		3
- 11	725379	. . POINTER		1
- 12	1090623	. . SCREW-SELF TAPPING, 3/16 LG.	ATT PT	2
- 13	482221	. . . KNOB ASSEMBLY,ROTARY		1
- 14	482195	. . . SPRING-CONTROL KNOB		1
- 15	482217	. . . KNOB ASSEMBLY,ROTARY		1
- 16	5349203	. SPACER- 0.625 OD X 0.06 THK		3
- 17	5796431	. SWITCH,ROTARY 1 DECK 2 POSITION		1
- 18	5276328	. SWITCH,ROTARY		2
- 19	5276229	. BRACKET-SWITCH MOUNTING		3
- 20	257189	. NUT,HEX- 8-32	ATT PT	6
- 21	1090873	. WASHER,LOCK,SPLIT RING- .168 ID, .296 OD	ATT PT	6
- 22	22478	. WASHER,FL- 0.170 ID 0.375 OD 0.32 THK	ATT PT	6
- 23	5276219	. BRACKET,LEVER SWITCH		3
- 24	257189	. NUT,HEX- 8-32	ATT PT	12
- 25	1090873	. WASHER,LOCK,SPLIT RING- .168 ID, .296 OD	ATT PT	12
- 26	22478	. WASHER,FL- 0.170 ID 0.375 OD 0.32 THK	ATT PT	12
- 27	5350020	. BUTTON,START-ENGLISH		1
- 28	5311440	. SPRING,BUTTON		1
- 29	551687	. SWITCH,PUSHBUTTON		1
- 30	5311437	. NUT,SWITCH 0.469-32	ATT PT	1
- 31	5373660	. HOUSING-SWITCH AND LIGHT		1
- 32	5276497	. BRACKET-PUSHBUTTON SWITCH MTG		1
- 33	257189	. NUT,HEX- 8-32	ATT PT	2
- 34	1090873	. WASHER,LOCK,SPLIT RING- .168 ID, .296 OD	ATT PT	2
- 35	22478	. WASHER,FL- 0.170 ID 0.375 OD 0.32 THK	ATT PT	2
- 36	824471	. LENS, CHECK RESET		1
- 37	2495641	. BUTTON		1
- 38	5276181	. BUTTON,SYSTEM RESET		1
- 39	5276188	. BUTTON,R.O.S. TRANSFER		1
- 40	5399632	. BUTTON-OPAQUE		1
- 41	5363966	. BUTTON,PSW RESTART		1
- 42	824466	. BUTTON, DISPLAY, BLUE		1
- 43	824467	. BUTTON, STORE, BLUE		1
- 44	5276183	. BUTTON,SET IC		1
- 45	5276187	. BUTTON,LOGOUT		1
- 46	483982	. BUTTON-CBM-BLUE		1
- 47	749033	. BUTTON-STOP		1
- 48	5311440	. SPRING,BUTTON		12
- 49	551687	. SWITCH,PUSHBUTTON		12
- 50	5311437	. NUT,SWITCH 0.469-32	ATT PT	12
- 51	5373660	. HOUSING-SWITCH AND LIGHT		12
- 52	5276239	. BRACKET,MOUNTING,PUSH BUTTON SWITCH		1
- 53	257189	. NUT,HEX- 8-32	ATT PT	4
- 54	1090873	. WASHER,LOCK,SPLIT RING- .168 ID, .296 OD	ATT PT	4
- 55	22478	. WASHER,FL- 0.170 ID 0.375 OD 0.32 THK	ATT PT	4
- 56	5781370	. PANEL F-CE CONSOLE		1

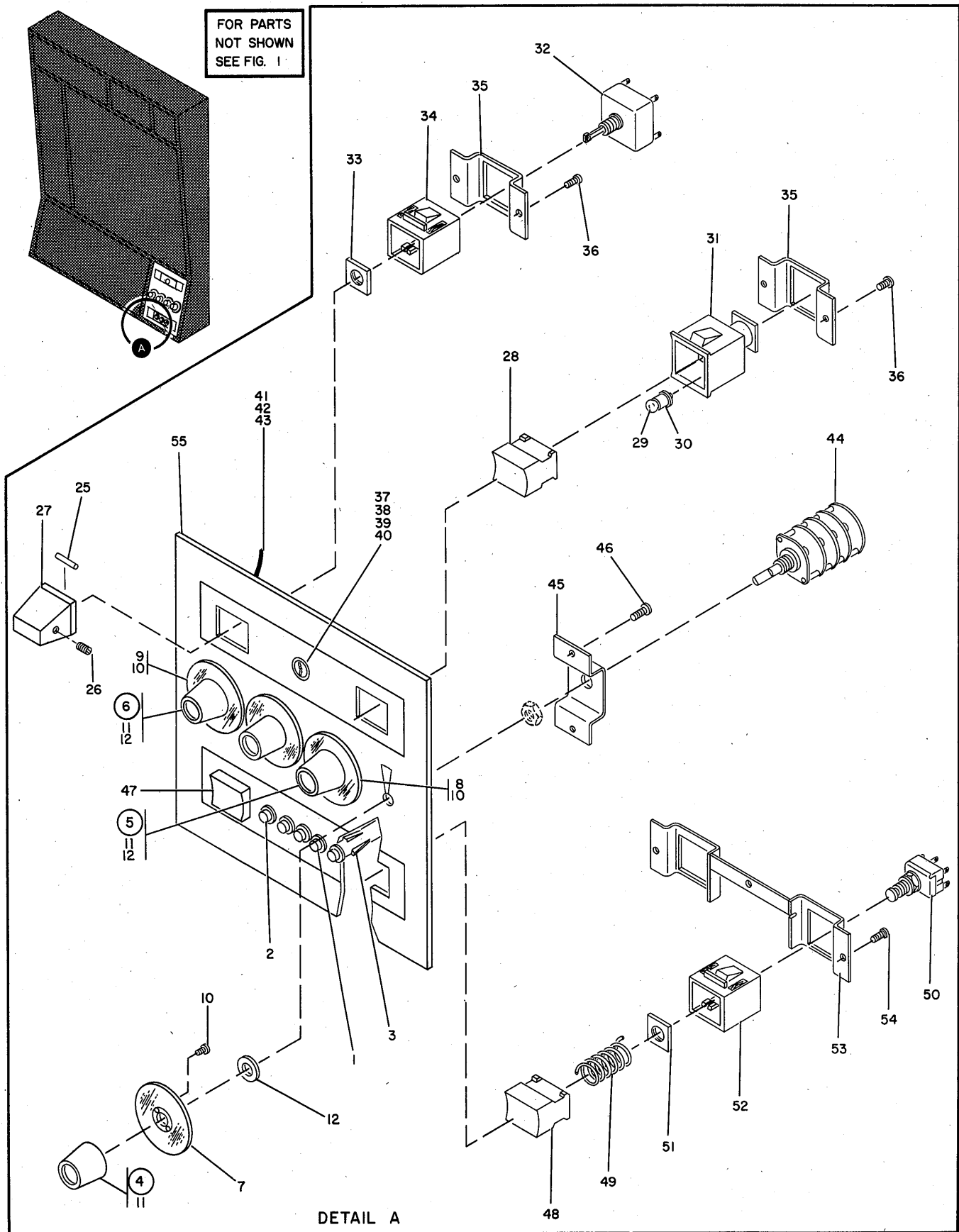
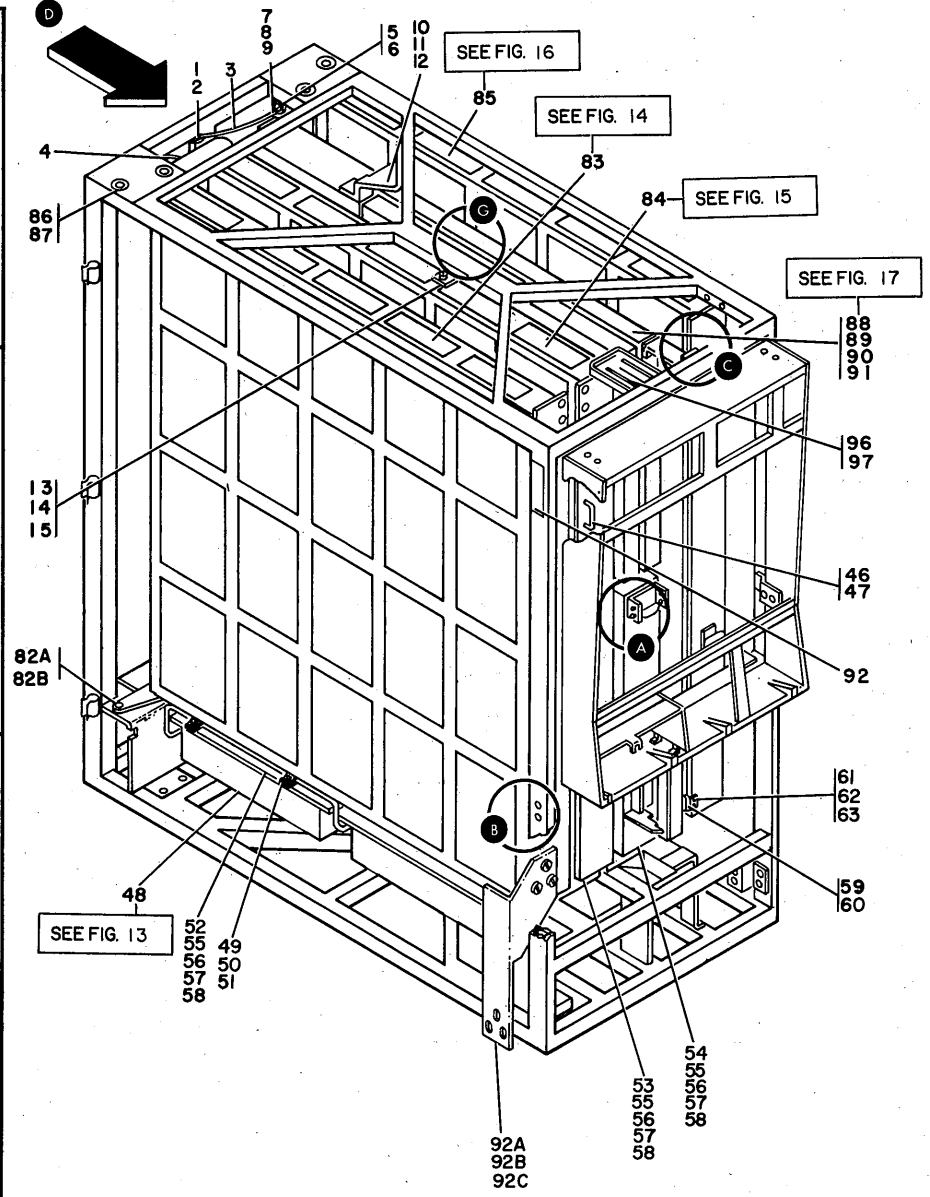
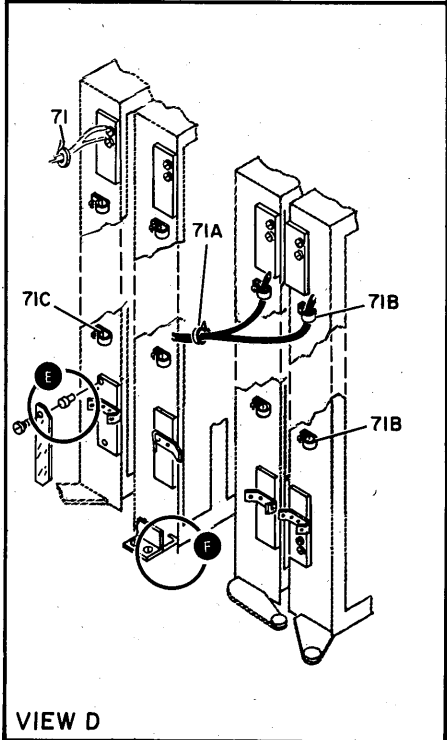
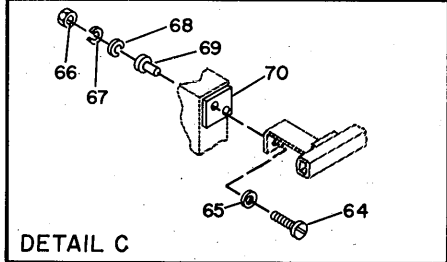
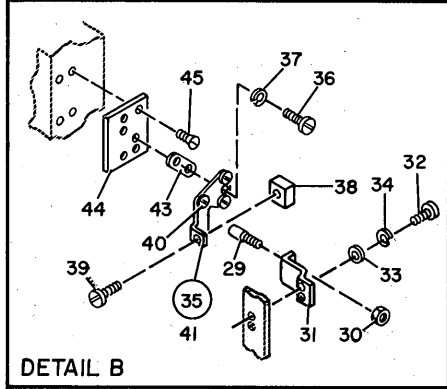
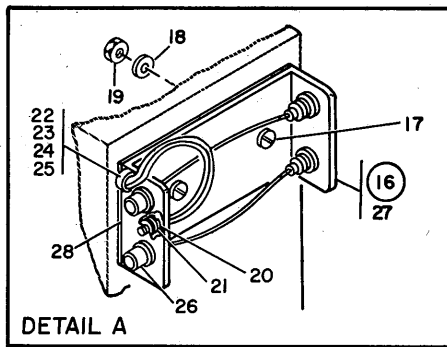

FIGURE 11. CE CONSOLE PANEL ASSEMBLY-G.

LIST 11. CE CONSOLE PANEL ASSEMBLY-G

FIGURE- INDEX NUMBER	PART NUMBER	DESCRIPTION				UNITS PER ASM.	USABLE ON CODE
		1	2	3	4		
11 -	5781326	PANEL G ASSEMBLY CE CONSOLE FOR NEXT HIGHER ASM, SEE FIG. 1-7				REF	
- 1	5353883	. INDICATOR ASM-AMBER-3 VOLT				1	
- 2	5353889	. INDICATOR ASM, CLEAR				4	
- 3	5353888	. HOUSING				5	
- 4	5349219	. KNOB AND DIAL ASM- 16 POS				2	
- 5	5383166	. KNOB AND DIAL ASM- 11 POS				1	
- 6	5781463	. KNOB AND DIAL ASM- 10 POSITION				1	
- 7	5349217	. . DIAL, 16 POS				1	
- 8	5383279	. . DIAL, 11 POSITION				1	
- 9	5781462	. . DIAL- 10 POSITION				1	
- 10	1090623	. . SCREW-SELF TAPPING, 3/16 LG. ATT PT				2	
- 11	482221	. . KNOB ASSEMBLY, ROTARY				1	
- 12	5211036	. SPACER-TEFLON 0.255 ID 5/8 OD 0.060 THK				4	
- 25	5382447	. KEY				1	
- 26	1092177	. SCREW, MACH-SET 4-40 X 3/16 LG ATT PT				2	
- 27	5311421	. COVER, TOGGLE SWITCH				1	
- 28	5711771	. BUTTON-INDICATOR POWER SEQUENCE COMPLETE				1	
- 29	2414970	. LAMP, INCANDESCENT				1	
- 30	827840	. SOCKET, SINGLE CONTACT, BAYONET BASE				1	
- 31	5373660	. HOUSING-SWITCH AND LIGHT				1	
- 32	5311439	. SWITCH, TOGGLE DPDT				1	
- 33	5311437	. NUT, SWITCH 0.469-32 ATT PT				1	
- 34	5373660	. HOUSING-SWITCH AND LIGHT				1	
- 35	5363987	. PLATE-SWITCH				2	
- 36	186759	. SCREW, MACH-BIND HD 8-32 X 5/16 LG ATT PT				4	
- 37	5213492	. SWITCH-DPDT				1	
- 38	81693	. SCREW, MACH-BIND HD 6-32 X 3/8 LG ATT PT				2	
- 39	6364	. WASHER, LOCK-SPLIT NO. 6 X 1/4 OD ATT PT				2	
- 40	257986	. WASHER, FLAT NO. 6 ATT PT				2	
- 41	5759502	. JUMPER ASM				1	
- 42	257189	FOR COMPONENT PARTS SEE FIG. 59-36F . NUT, HEX- 8-32 ATT PT				1	
- 43	55901	. WASHER, LOCK-EXT TEETH NO. 8 X 0.381 OD ATT PT				1	
- 44	5270179	. SWITCH, ROTARY-16 POS				4	
- 45	5363991	. BRACKET-SWITCH MTG				4	
- 46	186759	. SCREW, MACH-BIND HD 8-32 X 5/16 LG ATT PT				8	
- 47	5349961	. BUTTON, INTERRUPT				1	
- 48	5276180	. BUTTON, LOAD				1	
- 49	5311440	. SPRING, BUTTON				2	
- 50	551687	. SWITCH, PUSHBUTTON				2	
- 51	5311437	. NUT, SWITCH 0.469-32 ATT PT				2	
- 52	5373660	. HOUSING-SWITCH AND LIGHT				2	
- 53	5383167	. BRACKET-SWITCH MTG				1	
- 54	186759	. SCREW, MACH-BIND HD 8-32 X 5/16 LG ATT PT				3	
- 55	5781371	. PANEL				1	



SEE LIST 58
FOR CABLES

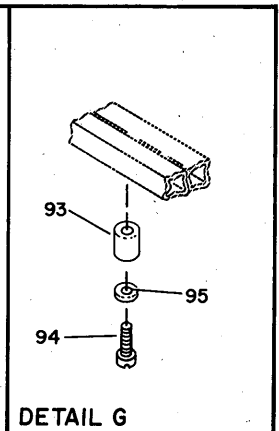
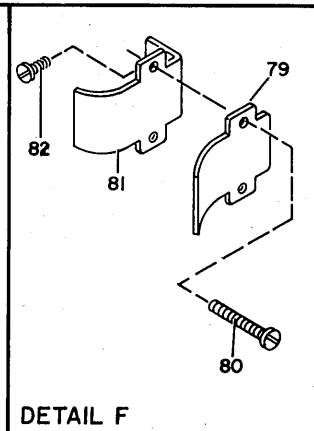
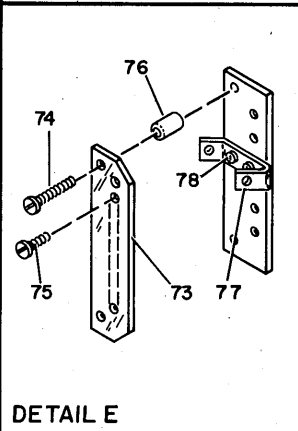

FIGURE 12. CPU FINAL ASSEMBLY-FRAME 02. (SHEET 1 OF 2, INDEX NOS. 1-97)

LIST 12. CPU FINAL ASSEMBLY-FRAME 02

FIGURE- INDEX NUMBER	PART NUMBER	DESCRIPTION	UNITS PER ASM.	USABLE ON CODE
12 -	5781301	CPU FINAL ASSEMBLY-FRAME 01	REF	
- 1	5319854	• SCREW, THD CUTTING-HEX HD 8-32 X 0.375 LG	1	
- 2	55901	• WASHER, LOCK-EXT TEETH NO. 8 X 0.381 OD	1	
- 3	5782240	• JUMPER ASM FOR COMPONENT PARTS SEE FIG. 59-34A	1	
- 4	5782239	• JUMPER ASSEMBLY FOR COMPONENT PARTS SEE FIG. 59-34A	2	
- 5	28413	• SCREW, MACH-BIND HD 10-32 X 5/16 LG	3	ATT PT
- 6	56079	• WASHER, LOCK-EXT T. .195 ID .410 OD	3	ATT PT
- 7	5240501	• STRAP, BONDING, 2.63 IN LG	1	
- 8	5319888	• SCREW, SELF TAPPING, 10-32 X .625 LONG	1	ATT PT
- 9	2125974	• WASHER, INT TOOTH, .200 ID X .562 OD	2	ATT PT
- 10	5372743	• BRACKET, RUS GATE	1	
- 11	75449	• SCREW, CAP, SOC HD- 10-32 X 3/8 LG	2	ATT PT
- 12	5319888	• SCREW, SELF TAPPING, 10-32 X .625 LONG	2	ATT PT
- 13	5353288	• BRACKET, ANGLE-BUMPER	1	
- 14	52580	• SCREW, MACH-FLAT CSK HD 10-32 X 0.750 LG	3	ATT PT
- 15	11598	• NUT, PLAIN-HEX 10-32 X 3/8 FL W	3	ATT PT
- 16	5737686	• SYNC ASSEMBLY	1	
- 17	532991	• SCREW	2	ATT PT
- 18	45690	• WASHER, FL - NO.10 X 7/16 OD X 1/32 THK	4	ATT PT
- 19	11598	• NUT, PLAIN-HEX 10-32 X 3/8 FL W	2	ATT PT
- 20	81693	• SCREW, MACH-BIND HD 6-32 X 3/8 LG	1	
- 21	56722	• WASHER, LOCK-EXT TEETH NO. 6	1	
- 22	357433	• CLAMP, LOOP- 0.187 ID 0.203 DIA MTG HOLE	1	
- 23	38235	• SCREW, MACH-BIND HD 6-32 X 0.312 LG	1	ATT PT
- 24	6364	• WASHER, LOCK-SPLIT NO. 6 X 1/4 OD	1	ATT PT
- 25	257986	• WASHER, FLAT NO. 6	1	ATT PT
- 26	5112828	• CABLE CONNECTOR	4	
- 27	5737685	• BRACKET-SYNC POINT	1	
- 28	5737684	• INSULATOR	1	
- 29	5353339	• STUD-GATE LATCH	2	
- 30	24107	• NUT, PLAIN, HEX- 3/8 X 9/16 FL W	2	
- 31	5353278	• BRACKET, MOUNTING, STUD	2	
- 32	332620	• SCREW, MACH-BIND HD 10-32 X 1/2 LG	4	ATT PT
- 33	45690	• WASHER, FL - NO.10 X 7/16 OD X 1/32 THK	4	ATT PT
- 34	9092	• WASHER-LOCK, SPLIT RING, .194 ID .3370D	4	ATT PT
- 35	5353281	• HANDLE ASSEMBLY, GATE LATCH, LH	1	
- 35	5353282	• HANDLE ASSEMBLY, GATE LATCH, RH	1	
- 36	5403812	• SCREW, SHOULDER- 10-32 X 3/8 THD	2	ATT PT
- 37	56121	• WASHER, LOCK-INT TEETH NO. 10 X 0.381 OD	2	ATT PT
- 38	5353336	• KNOB-LATCH	1	
- 39	119	• SCREW, MACH-FL CSK HD 8-32 X 1/2 LG	1	ATT PT
- 40	5353337	• SCREW-GATE HANDLE CPU- 70	3	
- 41	5353335	• HANDLE-GATE LATCH, RH	1	
- 41	5353028	• HANDLE-GATE LATCH L.H.	1	
- 43	5353277	• LINK, RIGID	2	
- 44	5353280	• PLATE, STRIKER	2	
- 45	5372858	• SCREW, HEX HD 10-32 X .50 LG	8	ATT PT
- 46	319300	• HANDLE	1	
- 47	32042	• SCREW, MACH BIND. HD 10-32 X 3/8 LG.	2	ATT PT
- 48	5357002	• COOLING UNIT FOR DETAIL BREAKDOWN, SEE FIGURE 13	8	
- 49	188555	• CLAMP, LOOP- 5/16 ID 9/64 DIA MTG HOLE	8	
- 50	79778	• SCREW-SELF TAPPING NO. 6-32 X 5/16 LG	8	ATT PT
- 51	56722	• WASHER, LOCK-EXT TEETH NO. 6	8	ATT PT
- 52	5733979	• HEADER-GATE A	1	
- 53	5753531	• HEADER ASSEMBLY, GATE B	1	
- 54	5357036	• HEADER ASSEMBLY	2	
- 55	34512	• SCREW, BIND.HD 8-32 X .375 LG	16	ATT PT
- 56	55901	• WASHER, LOCK-EXT TEETH NO. 8 X 0.381 OD	16	ATT PT
- 57	45690	• WASHER, FL - NO.10 X 7/16 OD X 1/32 THK	16	ATT PT
- 58	349736	• SEAL	4	
- 59	5353107	• BUMPER, GATE	1	
- 60	34512	• SCREW, BIND.HD 8-32 X .375 LG	2	ATT PT
- 61	5353171	• BRACKET, ANGLE	1	
- 62	34512	• SCREW, BIND.HD 8-32 X .375 LG	2	ATT PT
- 63	22478	• WASHER, FL- 0.170 ID 0.375 OD 0.32 THK	2	ATT PT
- 64	110286	• SCREW-MACHINE	2	
- 65	256463	• WASHER, FLAT, 7/16 OD X 0.250 ID X 0.031	2	
- 66	55586	• NUT, CHECK, HEX-1/4-20 X 1/8 FL W	2	
- 67	6935	• WASHER, LOCK-SPLIT 1/4 X 0.493 OD	2	
- 68	3550	• WASHER, FL- 1/4 X 9/16 OD X 0.050 THK	2	
- 69	5703002	• BUSHING	2	

LIST 12. CPU FINAL ASSEMBLY-FRAME 02

FIGURE- INDEX NUMBER	PART NUMBER	DESCRIPTION	UNITS PER ASM.	USABLE ON CODE
12 -	70	5703003	• SPACER	1
- 71	760221	• TIE, CABLE	AR	
- 71A	556450	• CLAMP-ADJUSTABLE CABLE	4	
- 71B	2102368	• CLAMP, LOOP- 0.880 ID 0.200 DIA MTG HOLE	3	
- 71C	2102369	• CLAMP, LOOP- 1.230 ID 0.200 DIA MTG HOLE	3	
- 73	811534	• COVER	2	
- 74	438581	• SCREW, MACH-FIL H 8-32 X 2 LG	4	ATT PT
- 75	2031	• SCREW, MACH-FIL H 8-32 X 5/8 LG	4	ATT PT
- 76	504318	• SPACER- 0.218 ID X 0.343 OD X 1.250 THK	4	
- 77	5271878	• TERMINAL	AR	
- 78	5736024	• SCREW, MACH-FIL H UNDERCUT 8-32 X 3/8 LG	AR	ATT PT
- 79	815217	• BACKPLATE, CLAMP	1	
- 80	438582	• SCREW, MACH-FIL H 8-32 X 2-1/4 LG	2	ATT PT
- 81	815214	• PLATE-BACK	1	
- 82	813706	• SCREW, SELF TAPPING- WASH HD 10-32 X 3/8	2	ATT PT
- 82A	5353026	• PIN-HINGE	1	
- 82B	5782296	• COLLAR	1	
- 83	5781307	• A GATE ASSEMBLY FOR DETAIL BREAKDOWN SEE FIGURE 14	1	
- 84	5781308	• B GATE ASSEMBLY FOR DETAIL BREAKDOWN SEE FIGURE 15	1	
- 85	5781310	• E GATE ASSEMBLY FOR DETAIL BREAKDOWN SEE FIGURE 16	1	
- 86	5353026	• PIN-HINGE	6	ATT PT
- 87	32042	• SCREW, MACH BIND. HD 10-32 X 3/8 LG.	6	ATT PT
- 88	NO NO.	• C/D GATE ASSEMBLY FOR DETAIL BREAKDOWN SEE FIGURE 17	NP	
- 89	36844	• SCREW, CAP-HEX HD SLOTTED 1/4-20 X 5/8 LG	4	ATT PT
- 90	6935	• WASHER, LOCK-SPLIT 1/4 X 0.493 OD	4	ATT PT
- 91	3550	• WASHER, FL- 1/4 X 9/16 OD X 0.050 THK	4	ATT PT
- 92	2569395	• LABEL-WARNING	2	
- 92A	5782244	• SUPPORT, GATE	1	
- 92B	322028	• SCREW, MACH-BIND HD 1/4-20 X 3/4 LG	3	ATT PT
- 92C	3550	• WASHER, FL- 1/4 X 9/16 OD X 0.050 THK	3	ATT PT
- 93	5353027	• BUMPER-FRAME	1	
- 94	5372859	• SCREW	1	ATT PT
- 95	45690	• WASHER, FL - NO.10 X 7/16 OD X 1/32 THK	1	ATT PT
- 96	5372711	• TRACK, CONSOLE	1	
- 97	5319888	• SCREW, SELF TAPPING, 10-32 X .625 LONG	4	ATT PT

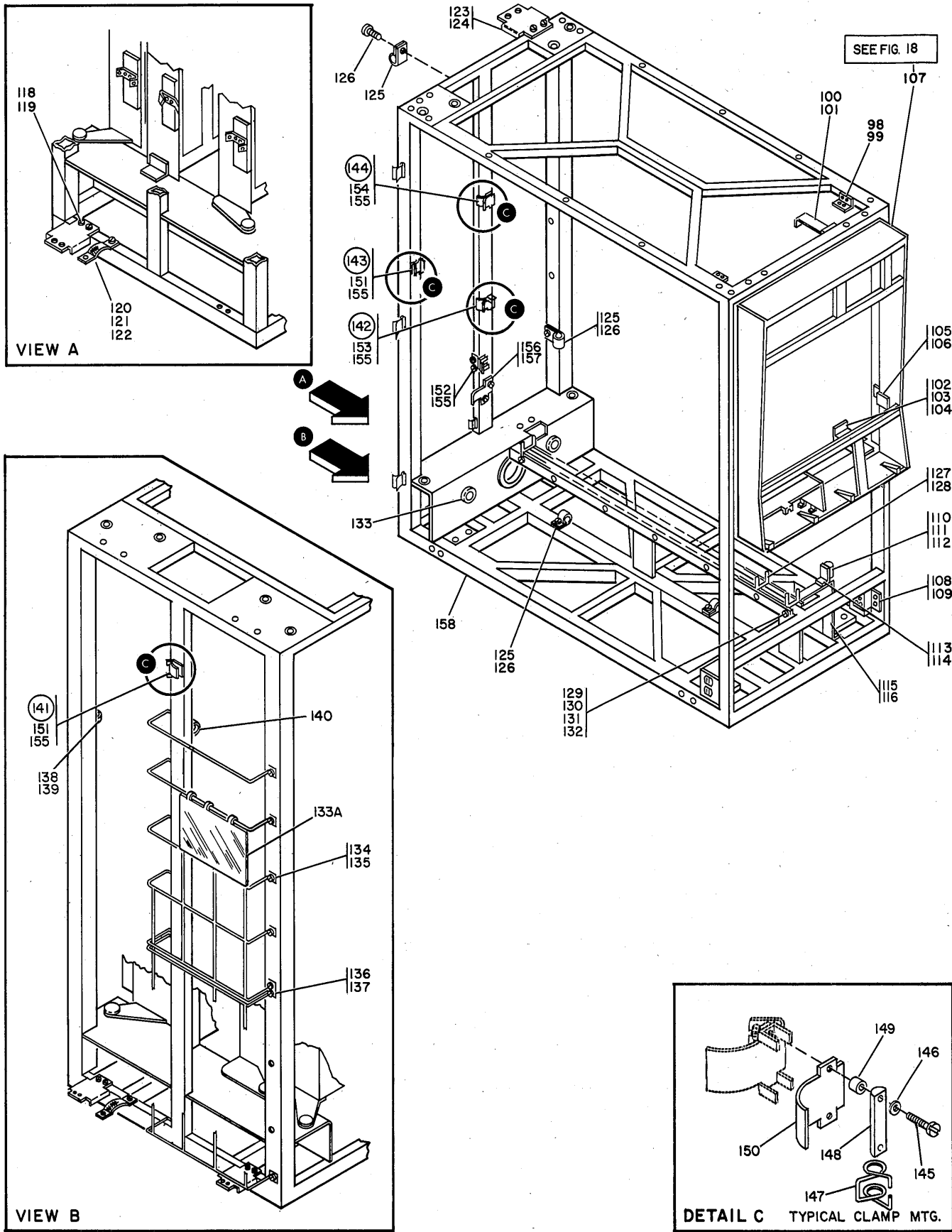

FIGURE 12. CPU FINAL ASSEMBLY-FRAME 02. (SHEET 2 OF 2, INDEX NOS. 98-158)

LIST 12. CPU FINAL ASSEMBLY-FRAME 02

FIGURE- INDEX NUMBER	PART NUMBER	DESCRIPTION	UNITS PER ASM.	USABLE ON CODE
12 - 98	5372716	. BRACKET,ANGLE	2	
- 99	5319888	. SCREW, SELF TAPPING, 10-32 X .625 LONG ATT PT	4	
-100	5372746	. BRACKET,DOUBLE ANGLE,ROS GATE	1	
-101	5319888	. SCREW, SELF TAPPING, 10-32 X .625 LONG ATT PT	2	
-102	5372712	. BRACKET,CONSOLE SLIDE	2	
-103	32042	. SCREW, MACH BIND. HD 10-32 X 3/8 LG. ATT PT	4	
-104	99	. SCREW,MACH-FL CSK HD 10-32 X 3/8 LG ATT PT	2	
-105	5372715	. BRACKET,DOUBLE ANGLE,CONSOLE MOUNTING	2	
-106	32042	. SCREW, MACH BIND. HD 10-32 X 3/8 LG. ATT PT	6	
-107	5781329	. CPU PANEL ASSEMBLY FOR DETAIL BREAKDOWN SEE FIGURE 18	1	
-108	5397869	. BRACKET	2	
-109	332620	. SCREW,MACH-BIND HD 10-32 X 1/2 LG ATT PT	4	
-110	5353107	. BUMPER, GATE	1	
-111	34512	. SCREW,BIND.HD 8-32 X .375 LG ATT PT	2	
-112	22478	. WASHER,FL- 0.170 ID 0.375 OD 0.32 THK ATT PT	2	
-113	5353287	. BRACKET,ANGLE-BUMPER	1	
-114	34512	. SCREW,BIND.HD 8-32 X .375 LG ATT PT	2	
-115	5353199	. BRACKET-GATE SUPPORT	1	
-116	5319888	. SCREW, SELF TAPPING, 10-32 X .625 LONG ATT PT	3	
-118	5372797	. BRACKET	2	
-119	813706	. SCREW,SELF TAPPING- WASH HD 10-32 X 3/8 ATT PT	4	
-120	5240500	. STRAP	1	
-121	813706	. SCREW,SELF TAPPING- WASH HD 10-32 X 3/8 ATT PT	1	
-122	56079	. WASHER,LOCK-EXT T .195 ID .410 OD ATT PT	1	
-123	5372797	. BRACKET	2	
-124	813706	. SCREW,SELF TAPPING- WASH HD 10-32 X 3/8 ATT PT	4	
-125	2102365	. CLAMP,LOOP- 0.330 ID 0.170 DIA MTG HOLE	8	
-126	332620	. SCREW,MACH-BIND HD 10-32 X 1/2 LG ATT PT	8	
-127	5397697	. WIREWAY	1	
-128	811427	. STRAP,CABLE	7	
-129	438602	. SCREW,MACH-BIND HD 10-32 X 1-1/2 LG ATT PT	7	
-130	45690	. WASHER, FL - NO.10 X 7/16 OD X 1/32 THK ATT PT	7	
-131	9092	. WASHER-LOCK,SPLIT RING, .194 ID .337OD ATT PT	7	
-132	11598	. NUT,PLAIN-HEX 10-32 X 3/8 FL W ATT PT	7	
-133	334012	. CHANNEL-RUBBER	AR	
-133A	5781893	. CABLE GUARD	1	
-134	5781352	. PANEL-SEQUENCING-UPPER	1	
-135	32042	. SCREW, MACH BIND. HD 10-32 X 3/8 LG. ATT PT	10	
-136	5781353	. PANEL-SEQUENCING-LOWER	1	
-137	32042	. SCREW, MACH BIND. HD 10-32 X 3/8 LG. ATT PT	8	
-138	1127180	. CLAMP,LOOP- 1-1/8 ID 0.199 MTG HOLE	1	
-139	332620	. SCREW,MACH-BIND HD 10-32 X 1/2 LG ATT PT	1	
-140	5716291	. CLAMP, LOOP-CUSHIONED	1	
-141	815224	. PLATE ASM,0-0.43 CABLE BUILD-UP	4	
-142	815226	. PLATE ASM,0.95-1.50 CABLE BUILD-UP	5	
-143	815225	. PLATE ASM,0.44-0.94 CABLE BUILD-UP	3	
-144	5781838	. CLAMP ASSEMBLY-FRONT	2	
-145	815173	. . SCREW,CLAMP-HEX 90C HD 8-32 X 1.250 LG USED ON ASM 815224 ONLY	2	
-145	815175	. . SCREW,CLAMP-HEX SOC HD 8-32 X 2.250 LG USED ON ASM 815226 ONLY	2	
-145	815174	. . SCREW,CLAMP-HEX SOC HD 8-32 X 1.750 LG USED ON ASM 815225 ONLY	2	
-145	586711	. . SCREW-FILLESTER HEAD MACH 8 X 32 USED ON ASM 5781838 ONLY	2	
-146	815210	. . RING, RETAINING USED ON ASMS 815224 AND 815225 ONLY	2	
-146	816649	. . RETAINER USED ON ASMS 815226 AND 5781838 ONLY	2	
-147	813321	. . SPRING,TORSION- 2 RH AND 2 LH FULL TURNS	1	
-148	815220	. . BAR	1	
-149	815219	. . SPACER	1	
-150	815217	. . BACKPLATE,CLAMP	1	
-151	815288	. BACKPLATE	7	
-152	815290	. BACKPLATE-CABLE CLAMP	1	
-153	815214	. PLATE-BACK	4	
-154	5781828	. BACKPLATE	2	
-155	813706	. SCREW,SELF TAPPING- WASH HD 10-32 X 3/8 ATT PT	AR	
-156	2716280	. PLATE	17	
-157	507796	. SCREW,MACH-BIND HD 10-32 X 1 LG ATT PT	34	
-158	5781460	. FRAME-CPU	1	

FOR PARTS
NOT SHOWN
SEE FIG. 12,
23,24

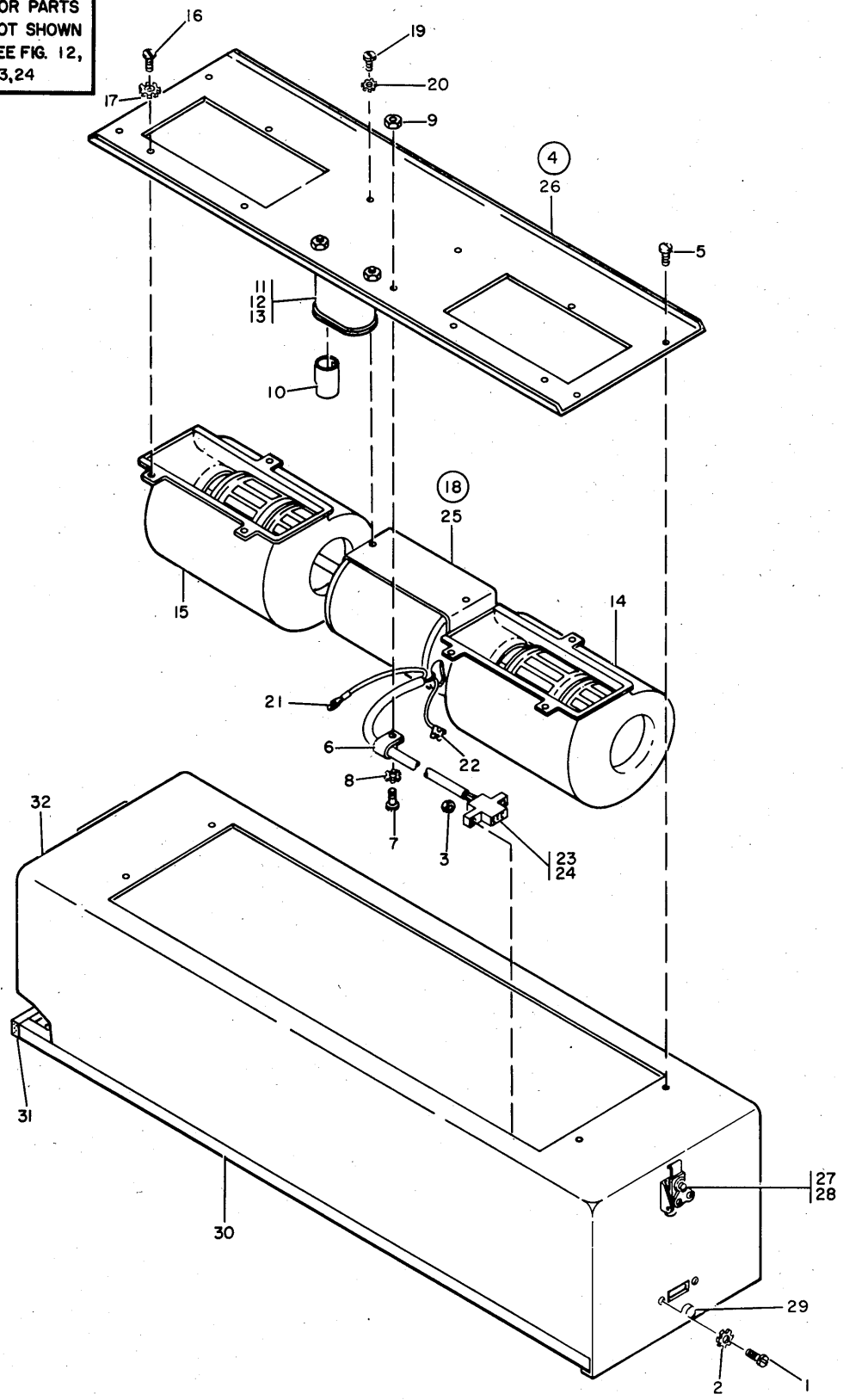
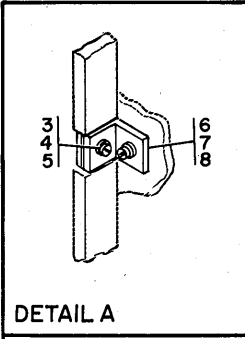
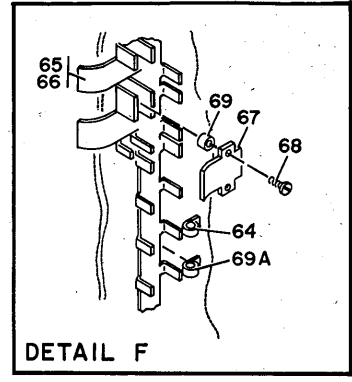
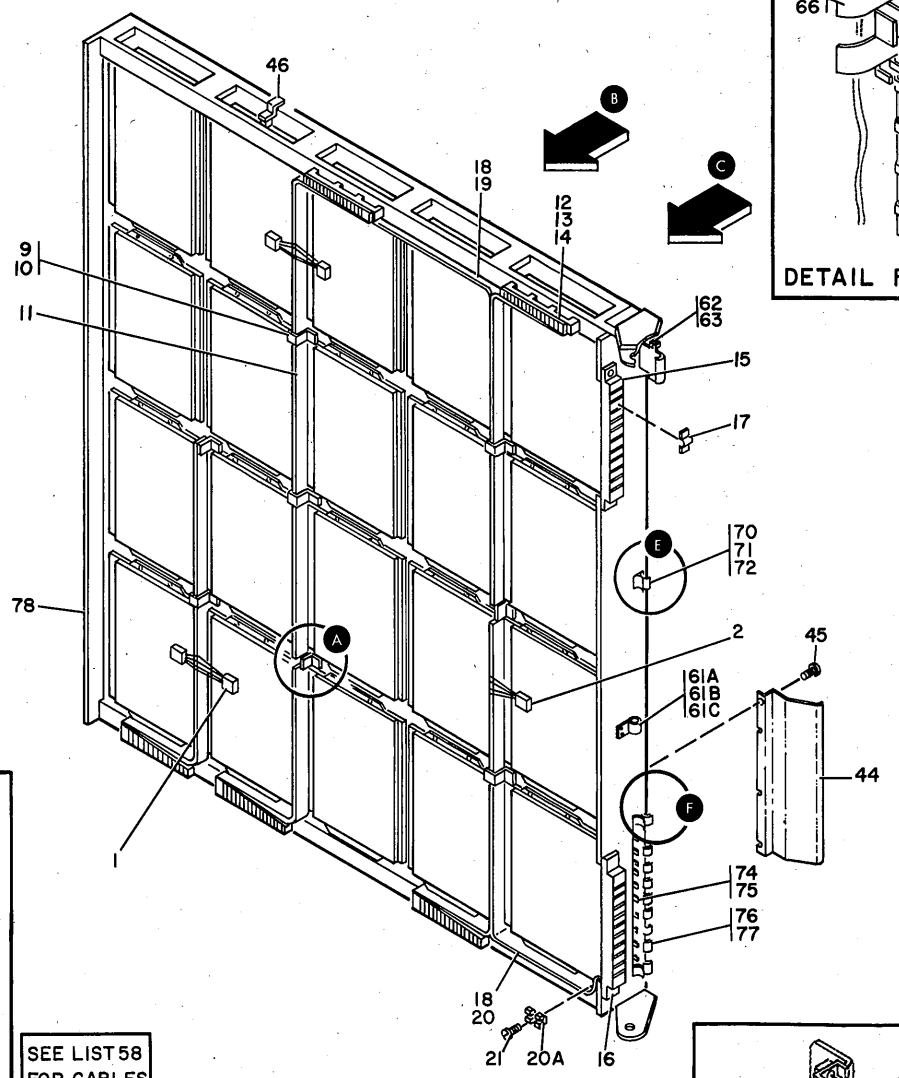

FIGURE 13. COOLING UNIT ASSEMBLY.

LIST 13. COOLING UNIT ASSEMBLY

FIGURE- INDEX NUMBER	PART NUMBER	DESCRIPTION				UNITS PER ASM.	USABLE ON CODE
		1	2	3	4		
13 -	5357002	COOLING UNIT ASSEMBLY-50/60 HZ FOR NEXT HIGHER ASM,SEE FIG. 12-48, 23-17 AND 24-33				REF	
- 1	322065	. SCREW,MACH-BIND HD 6-32 X 5/8 LG				2	
- 2	56722	. WASHER,LOCK-EXT TEETH NO. 6				2	
- 3	257187	. NUT,PLAIN,HEX- 6-32 X 3/8 FL W				2	
- 4	5357005	. BLOWER ASSEMBLY- 60 AND 50 HZ				1	
- 5	740501	. SCREW,MACH-HEX HD 6-32 X 0.250 LG		ATT PT	4		
- 6	804109	. CLAMP,LOOP- 3/8 ID 0.173 DIA MTG HOLE				1	
- 7	81693	. SCREW,MACH-BIND HD 6-32 X 3/8 LG		ATT PT	1		
- 8	56722	. WASHER,LOCK-EXT TEETH NO. 6		ATT PT	1		
- 9	257187	. NUT,PLAIN,HEX- 6-32 X 3/8 FL W		ATT PT	1		
- 10	526378	. CAP-INSULATION				2	
- 11	5357137	. CAPACITOR,P DIELEC- 30UF PM 10% 370V AC				1	
- 12	11598	. NUT,PLAIN-HEX 10-32 X 3/8 FL W		ATT PT	2		
- 13	56079	. WASHER,LOCK-EXT T .195 ID .410 OD				2	
- 14	5357145	. SCROLL AND WHEEL ASSEMBLY, RIGHT HAND				1	
- 15	5357144	. SCROLL AND WHEEL ASSEMBLY, LEFT HAND				1	
- 16	81693	. SCREW,MACH-BIND HD 6-32 X 3/8 LG		ATT PT	6		
- 17	56722	. WASHER,LOCK-EXT TEETH NO. 6		ATT PT	6		
- 18	5357020	. MOTOR AND CONNECTOR ASSEMBLY				1	
- 19	130434	. SCREW-MACH,SLOTTED HEX HD NO.10-32 X.375		ATT PT	2		
- 20	56079	. WASHER,LOCK-EXT T .195 ID .410 OD		ATT PT	2		
- 21	253740	. TERMINAL-RING,10-12 AWG,#6 HOLE,INS				1	
- 22	517913	. TERMINAL,SLIP ON-18-16 AWG				3	
- 23	5353853	. HOUSING				1	
- 24	5353854	. CONTACT, MALE 16-20 WIRE				3	
- 25	5357021	. MOTOR ASM- 3350 RPM 0.06 HP SP 50/60 CY				1	
- 26	5357012	. PLATE-DUPLEX MOUNTING				1	
- 27	5349888	. LATCH				1	
- 28	5357136	. SCREW,PAN HD-SELF TAP 4-40 X .187 LG		ATT PT	2		
- 29	5357135	. CATCH				1	
- 30	5357013	. FILTER,AIR				1	
- 31	599557	. SEAL				AR	
- 32	5357011	. HOUSING-DUPLEX BLOWER				1	

FOR PARTS
NOT SHOWN
SEE FIG. 12
SHEET 1



SEE LIST 58
FOR CABLES

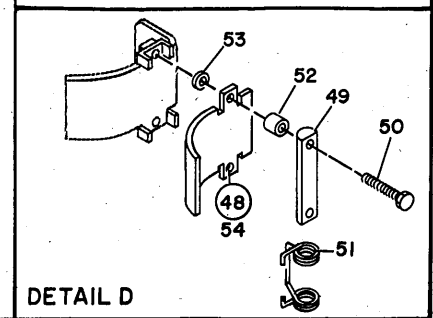
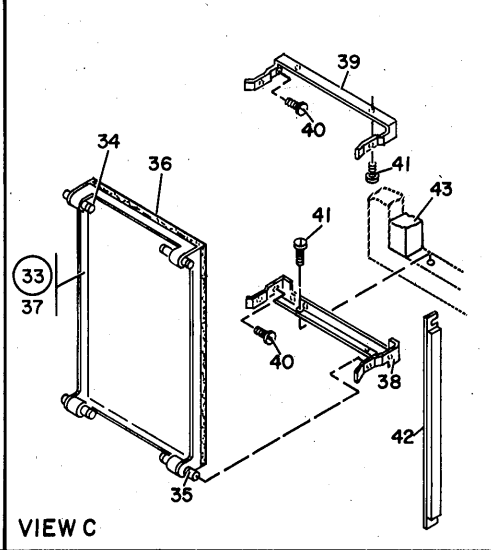
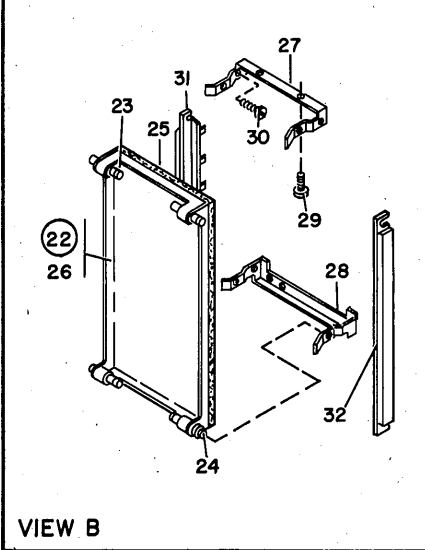
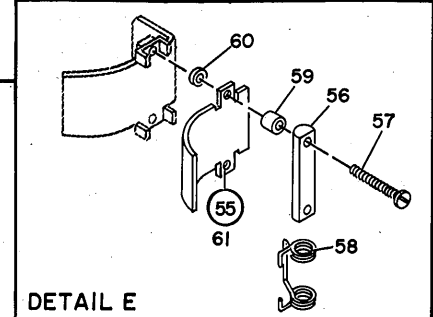

FIGURE 14. A GATE ASSEMBLY

LIST 14. A GATE ASSEMBLY

FIGURE- INDEX NUMBER	PART NUMBER	DESCRIPTION	UNITS PER ASM.	USABLE ON CODE
14 -	5781307	A GATE ASSEMBLY	REF	
- 1	811621	FOR NEXT HIGHER ASM, SEE FIGURE 12-83 • CROSSOVER ASSEMBLY	40	
- 2	811483	FOR COMPONENT PARTS SEE FIG. 59-46 • CROSSOVER ASSEMBLY	20	
- 3	5356580	FOR COMPONENT PARTS SEE FIG. 59-50 • SCREW, MACH-BIND HD 4-40 X 1/2 LG	3	
- 4	815039	• WASHER, FL-NO 4 X 1/8 ID X 1/4 OD	3	
- 5	5373223	• NUT, PLAIN, HEX- 4-40 X 0.250 FL W	3	
- 6	811742	• SUPPORT	3	
- 7	811426	• SCREW, MACH-PAN HD 6-32 X 3/8 IN. LG	3	ATT PT
- 8	2129550	• WASHER, FLAT- 5/16 OD 5/32 ID 1/32 THK	3	ATT PT
- 9	815946	• STRAP ASSEMBLY-BUS	6	
- 10	811426	• SCREW, MACH-PAN HD 6-32 X 3/8 IN. LG	12	ATT PT
- 11	811520	• BUS ASSEMBLY, VERT., 2 BOARD	6	
- 12	811481	• SCREW, MACH- 6-32 X 1/4 LG	72	
- 13	811476	• TERMINAL BLOCK, BUS TO BUS	6	
- 14	38391	• SCREW MACHINE, FIL HD	12	ATT PT
- 15	5779917	• MARKER STRIP	1	
- 16	5779915	• MARKER STRIP	1	
- 17	811576	• JUMPER-BUS 4 POSITION	2	
- 18	811442	• SEAL	8	
- 19	811515	• BUS ASSEMBLY, HORIZ. GRP 1, 4 BOARD	1	
- 20	811517	• BUS ASSEMBLY, HORIZ. GRP 2, 4 BOARD	1	
- 20A	813179	• CLAMP-BOARD	160	
- 21	811417	• SCREW, HEX SOCKET H- 6-32 X 1/2 LG	160	ATT PT
- 22	5728866	• COVER ASSEMBLY	4	
- 23	815963	• . CATCH-PULL	4	
- 24	815964	• . SPACER-HINGE	4	
- 25	5728864	• . FOAM-BACKING	1	
- 26	5728865	• . COVER	1	
- 27	5728863	• BRACKET-HINGE UPPER	4	
- 28	5728862	• BRACKET-HINGE LOWER	4	
- 29	811417	• SCREW, HEX SOCKET H- 6-32 X 1/2 LG	16	ATT PT
- 30	55726	• SCREW, MACH-BIND HD 6-32 X .188 LG	16	ATT PT
- 31	5353087	• BRACKET, DOUBLE ANGLE	4	
- 32	811881	• RETAINER ASSEMBLY	4	
- 33	811873	• COVER ASSEMBLY, CARD	16	
- 34	815963	• . CATCH-PULL	4	
- 35	815964	• . SPACER-HINGE	4	
- 36	815263	• . BACKING, FOAM	1	
- 37	811872	• . COVER	1	
- 38	811858	• BRACKET-HINGE	16	
- 39	811859	• BRACKET	16	
- 40	811417	• SCREW, HEX SOCKET H- 6-32 X 1/2 LG	64	ATT PT
- 41	55726	• SCREW, MACH-BIND HD 6-32 X .188 LG	64	ATT PT
- 42	811881	• RETAINER ASSEMBLY	32	
- 43	811442	• SEAL	AR	
- 44	5782086	• COVER-COAX CABLE	4	
- 45	5319854	• SCREW, THD CUTTING-HEX HD 8-32 X 0.375 LG	12	ATT PT
- 46	2573012	• SWITCH ASM	2	
- 48	815226	• PLATE ASM, 0.95-1.50 CABLE BUILD-UP	2	
- 49	815220	• . BAR	1	
- 50	815175	• . SCREW, CLAMP-HEX SOC HD 8-32 X 2.250 LG	2	ATT PT
- 51	813321	• . SPRING, TORSION- 2 RH AND 2 LH FULL TURNS	1	
- 52	815219	• . SPACER	2	
- 53	816649	• . RETAINER	2	
- 54	815217	• . BACKPLATE, CLAMP	1	
- 55	5781838	• CLAMP ASSEMBLY-FRONT	2	
- 56	815220	• . BAR	1	
- 57	586711	• . SCREW-FILLESTER HEAD MACH 8 X 32	2	ATT PT
- 58	813321	• . SPRING, TORSION- 2 RH AND 2 LH FULL TURNS	1	
- 59	815219	• . SPACER	2	
- 60	816649	• . RETAINER	2	
- 61	815217	• . BACKPLATE, CLAMP	1	
- 61A	2102368	• CLAMP, LOOP- 0.880 ID 0.200 DIA MTG HOLE	1	
- 61B	257189	• NUT, HEX- 8-32	1	ATT PT
- 61C	22478	• WASHER, FL- 0.170 ID 0.375 OD 0.32 THK	1	ATT PT

LIST 14. A GATE ASSEMBLY

FIGURE- INDEX NUMBER	PART NUMBER	DESCRIPTION	UNITS PER ASM.	USABLE ON CODE
14 - 62	815214	• PLATE-BACK	1	
- 63	813706	• SCREW, SELF TAPPING- WASH HD 10-32 X 3/8	2	ATT PT
- 64	356742	• CLAMP, LOOP- 0.250 ID 0.177 DIA MTG HOLE	4	
- 65	815166	• PLATE	4	
- 66	2191737	• SCREW, MACHINE	12	ATT PT
- 67	815217	• BACKPLATE, CLAMP	20	
- 68	2384	• SCREW, MACH-FIL H 8-32 X 1 IN LG.	30	ATT PT
- 69	5781840	• SPACER	12	
- 69A	2102368	• CLAMP, LOOP- 0.880 ID 0.200 DIA MTG HOLE	1	
- 70	5781828	• BACKPLATE	2	
- 71	2191737	• SCREW, MACHINE	2	ATT PT
- 72	5781840	• SPACER	1	
- 74	815214	• PLATE-BACK	2	
- 75	813706	• SCREW, SELF TAPPING- WASH HD 10-32 X 3/8	4	ATT PT
- 76	815217	• BACKPLATE, CLAMP	1	
- 77	438582	• SCREW, MACH-FIL H 8-32 X 2-1/4 LG	2	ATT PT
- 78	5728952	• GATE ASM-BOARD 2 HIGH OUTER	1	

FOR PARTS
NOT SHOWN
SEE FIG. 12
SHEET 1

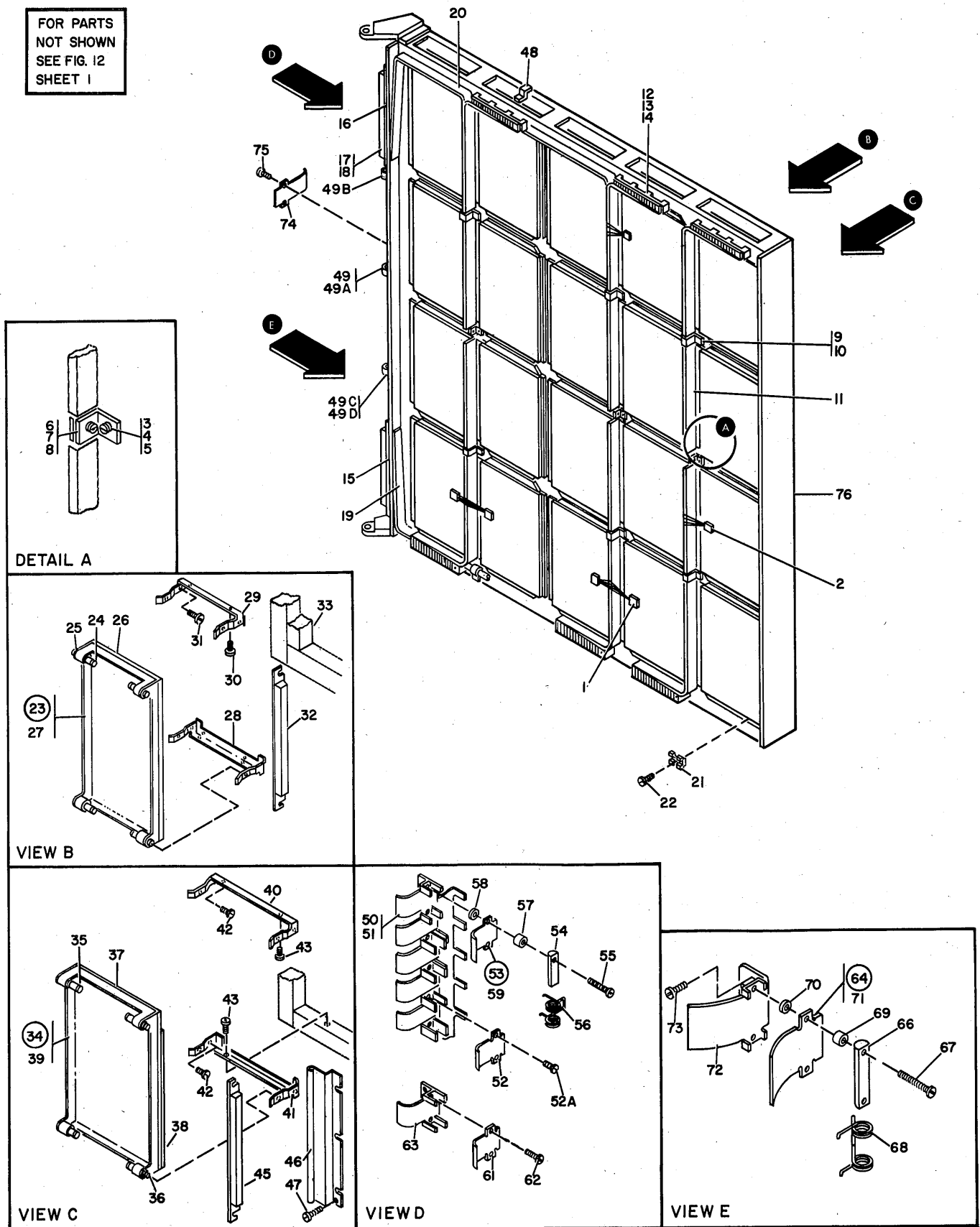

FIGURE 15. 8 GATE ASSEMBLY

LIST 15. B GATE ASSEMBLY

FIGURE- INDEX NUMBER	PART NUMBER	DESCRIPTION	UNITS PER ASM.	USABLE ON CODE
15 -	5781308	B GATE ASSEMBLY	REF	
- 1	811621	FOR NEXT HIGHER ASM, SEE FIGURE 12-84 • CROSSOVER ASSEMBLY	40	
- 2	811483	FOR COMPONENT PARTS SEE FIG. 59-46 • CROSSOVER ASSEMBLY FOR COMPONENT PARTS SEE FIG. 59-50	20	
- 3	5356580	• SCREW, MACH-BIND HD 4-40 X 1/2 LG	3	
- 4	815039	• WASHER, FL-NO 4 X 1/8 ID X 1/4 OD	3	
- 5	5373223	• NUT, PLAIN, HEX- 4-40 X 0.250 FL W	3	
- 6	811742	• SUPPORT	3	
- 7	811426	• SCREW, MACH-PAN HD 6-32 X 3/8 IN. LG	3	ATT PT
- 8	2129550	• WASHER, FLAT- 5/16 OD 5/32 ID 1/32 THK	3	ATT PT
- 9	815946	• STRAP ASSEMBLY-BUS	6	
- 10	811426	• SCREW, MACH-PAN HD 6-32 X 3/8 IN. LG	12	ATT PT
- 11	811520	• BUS ASSEMBLY, VERT., 2 BOARD	6	
- 12	811481	• SCREW, MACH- 6-32 X 1/4 LG	72	
- 13	811476	• TERMINAL BLOCK, BUS TO BUS	6	
- 14	38391	• SCREW MACHINE, FIL HD	12	ATT PT
- 15	5779915	• MARKER STRIP	1	
- 16	5779917	• MARKER STRIP	1	
- 17	811576	• JUMPER-BUS 4 POSITION	2	
- 18	811422	• SCREW, HEX H- 8-32 X 0.625 LG	8	ATT PT
- 19	811515	• BUS ASSEMBLY, HORIZ. GRP 1, 4 BOARD	1	
- 20	811517	• BUS ASSEMBLY, HORIZ. GRP 2, 4 BOARD	1	
- 21	813179	• CLAMP-BOARD	160	
- 22	811417	• SCREW, HEX SOCKET H- 6-32 X 1/2 LG	160	ATT PT
- 23	811873	• COVER ASSEMBLY, CARD	19	
- 24	815963	• CATCH-PULL	4	
- 25	815964	• SPACER-HINGE	4	
- 26	815263	• BACKING, FOAM	1	
- 27	811872	• COVER	1	
- 28	811858	• BRACKET-HINGE	19	
- 29	811859	• BRACKET	19	
- 30	811417	• SCREW, HEX SOCKET H- 6-32 X 1/2 LG	76	ATT PT
- 31	55726	• SCREW, MACH-BIND HD 6-32 X .188 LG	76	ATT PT
- 32	811881	• RETAINER ASSEMBLY	38	
- 33	811442	• SEAL	38	
- 34	5353219	• COVER ASSEMBLY, CARD	1	
- 35	815963	• CATCH-PULL	4	
- 36	815964	• SPACER-HINGE	4	
- 37	5353224	• FILLER, CARD COVER	1	
- 38	5765748	• STRIP, FOAM	2	
- 39	5353218	• COVER, CARD RACEWAY	1	
- 40	5353217	• BRACKET, HINGE, UPPER	1	
- 41	5353216	• BRACKET, HINGE, LOWER	1	
- 42	811417	• SCREW, HEX SOCKET H- 6-32 X 1/2 LG	4	ATT PT
- 43	55726	• SCREW, MACH-BIND HD 6-32 X .188 LG	4	ATT PT
- 44	811881	• RETAINER ASSEMBLY	1	
- 45	5737411	• COVER-SUPPORT	1	
- 46	5319854	• SCREW, THD CUTTING-HEX HD 8-32 X 0.375 LG	3	ATT PT
- 47	2573012	• SWITCH ASM	2	
- 48	356742	• CLAMP, LOOP- 0.250 ID 0.177 DIA MTG HOLE	1	
- 49A	813706	• SCREW, SELF TAPPING- WASH HD 10-32 X 3/8	1	ATT PT
- 49B	2102368	• CLAMP, LOOP- 0.880 ID 0.200 DIA MTG HOLE	1	
- 49C	2102369	• CLAMP, LOOP- 1.230 ID 0.200 DIA MTG HOLE	1	
- 49D	813706	• SCREW, SELF TAPPING- WASH HD 10-32 X 3/8	1	ATT PT
- 50	815166	• PLATE	1	
- 51	813706	• SCREW, SELF TAPPING- WASH HD 10-32 X 3/8	AR	ATT PT
- 52	815217	• BACKPLATE, CLAMP	1	
- 52A	2384	• SCREW, MACH-FIL H 8-32 X 1 IN LG.	2	ATT PT
- 53	5781838	• CLAMP ASSEMBLY-FRONT	1	
- 54	815220	• BAR	1	
- 55	586711	• SCREW-FILLESTER HEAD MACH 8 X 32	2	ATT PT
- 56	813321	• SPRING, TORSION- 2 RH AND 2 LH FULL TURNS	1	
- 57	815219	• SPACER	2	
- 58	816649	• RETAINER	2	
- 59	815217	• BACKPLATE, CLAMP	1	
- 61	5781828	• BACKPLATE	1	
- 62	813706	• SCREW, SELF TAPPING- WASH HD 10-32 X 3/8	2	ATT PT
- 63	815289	• BACKPLATE-CABLE CLAMP 45 DEG	2	

LIST 15. B GATE ASSEMBLY

FIGURE- INDEX NUMBER	PART NUMBER	DESCRIPTION	UNITS PER ASM.	USABLE ON CODE
15 - 64	815226	• PLATE ASM, 0.95-1.50 CABLE BUILD-UP	2	
- 66	815220	• BAR	1	
- 67	815175	• SCREW, CLAMP-HEX SOC HD 8-32 X 2.250 LG	2	ATT PT
- 68	813321	• SPRING, TORSION- 2 RH AND 2 LH FULL TURNS	1	
- 69	815219	• SPACER	2	
- 70	816649	• RETAINER	2	
- 71	815217	• BACKPLATE, CLAMP	1	
- 72	815214	• PLATE-BACK	2	
- 73	813706	• SCREW, SELF TAPPING- WASH HD 10-32 X 3/8	2	ATT PT
- 74	815217	• BACKPLATE, CLAMP	2	
- 75	2384	• SCREW, MACH-FIL H 8-32 X 1 IN LG.	4	ATT PT
- 76	5781831	• GATE ASM-BOARD 2 HIGH INNER	1	

FOR PARTS
NOT SHOWN
SEE FIG. 12
SHEET 1

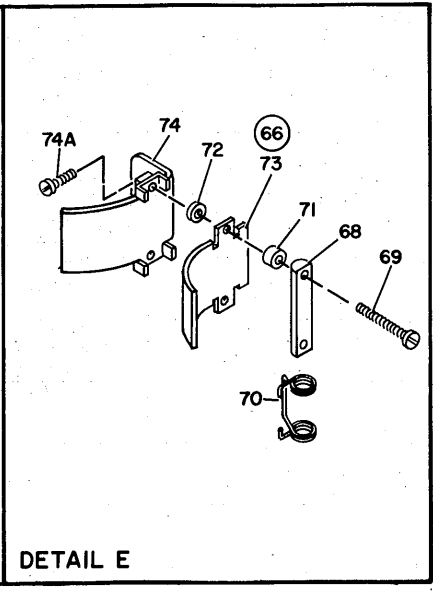
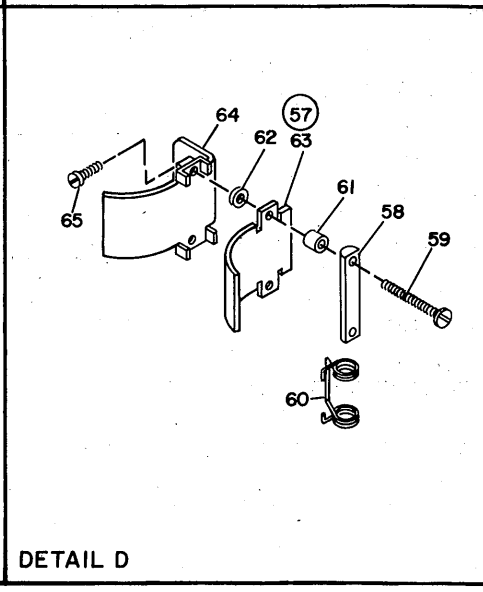
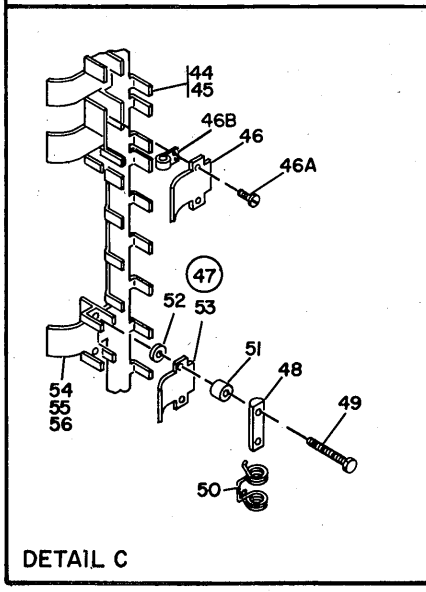
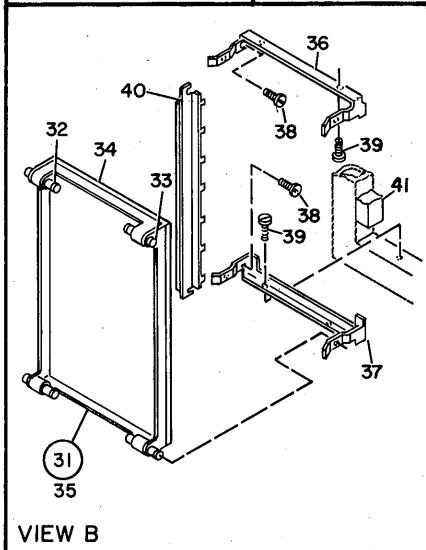
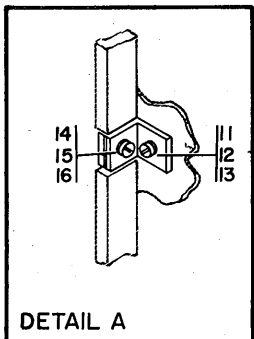
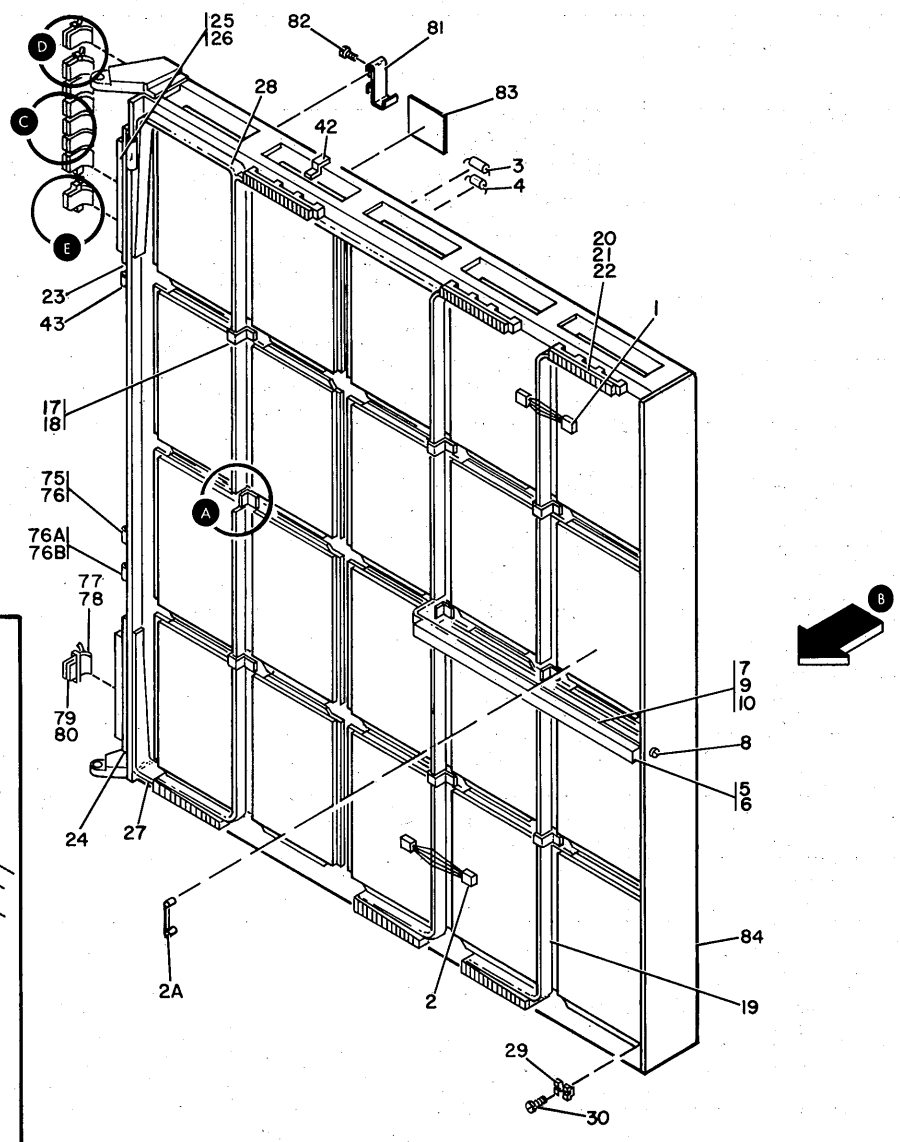

FIGURE 16. E GATE ASSEMBLY.

LIST 16. E GATE ASSEMBLY

FIGURE- INDEX NUMBER	PART NUMBER	DESCRIPTION	UNITS PER ASM.	USABLE ON CODE
16 -	5781310	E GATE ASSEMBLY	REF	
- 1	811483	FOR NEXT HIGHER ASM, SEE FIGURE 12-85 • CROSSOVER ASSEMBLY	20	
- 2	811621	FOR COMPONENT PARTS SEE FIG. 59-50 • CROSSOVER ASSEMBLY FOR COMPONENT PARTS SEE FIG. 59-46	40	
- 2A	815080	• STRAP	4	
- 3	5781837	• CAPACITOR ASM	1	
- 4	5781842	• CAPACITOR ASM	1	
- 5	5393093	• RAIL,RUB	1	
- 6	34512	• SCREW,BIND,HD 8-32 X .375 LG	4	ATT PT
- 7	5393095	• BRACKET,RAIL	1	
- 8	34512	• SCREW,BIND,HD 8-32 X .375 LG	1	ATT PT
- 9	734483	• SCREW,PAN HD- 6-32 X 0.380 LG	1	ATT PT
- 10	257986	• WASHER,FLAT NO. 6	1	ATT PT
- 11	5356580	• SCREW,MACH-BIND HD 4-40 X 1/2 LG	3	
- 12	815039	• WASHER,FL-NO 4 X 1/8 ID X 1/4 OD	3	
- 13	5373223	• NUT,PLAIN,HEX- 4-40 X 0.250 FL W	3	
- 14	811742	• SUPPORT	3	
- 15	811426	• SCREW,MACH-PAN HD 6-32 X 3/8 IN. LG	3	ATT PT
- 16	2129550	• WASHER,FLAT- 5/16 OD 5/32 ID 1/32 THK	3	ATT PT
- 17	815946	• STRAP ASSEMBLY-BUS	6	
- 18	811426	• SCREW,MACH-PAN HD 6-32 X 3/8 IN. LG	12	ATT PT
- 19	811520	• BUS ASSEMBLY, VERT., 2 BOARD	6	
- 20	811481	• SCREW,MACH- 6-32 X 1/4 LG	72	
- 21	811476	• TERMINAL BLOCK,BUS TO BUS	6	
- 22	38391	• SCREW MACHINE,FIL HD	12	ATT PT
- 23	5779917	• MARKER STRIP	1	
- 24	5779915	• MARKER STRIP	1	
- 25	811576	• JUMPER-BUS 4 POSITION	2	
- 26	811422	• SCREW,HEX H- 8-32 X 0.625 LG	6	ATT PT
- 27	811515	• BUS ASSEMBLY, HORIZ. GRP 1, 4 BOARD	1	
- 28	811517	• BUS ASSEMBLY, HORIZ. GRP 2, 4 BOARD	1	
- 29	813179	• CLAMP-BOARD	160	
- 30	811417	• SCREW,HEX SOCKET H- 6-32 X 1/2 LG	160	ATT PT
- 31	811877	• COVER ASSEMBLY-CARD	20	
- 32	815963	• CATCH-PULL	4	
- 33	815964	• SPACER-HINGE	4	
- 34	815263	• BACKING, FOAM	1	
- 35	811876	• COVER,CARD	1	
- 36	811863	• BRACKET-UPPER HINGE	20	
- 37	811862	• BRACKET-LOWER HINGE	20	
- 38	811417	• SCREW,HEX SOCKET H- 6-32 X 1/2 LG	80	ATT PT
- 39	55726	• SCREW,MACH-BIND HD 6-32 X .188 LG	80	ATT PT
- 40	811881	• RETAINER ASSEMBLY	40	
- 41	811442	• SEAL	40	
- 42	2573012	• SWITCH ASM	2	
- 43	356742	• CLAMP,LOOP- 0.250 ID 0.177 DIA MTG HOLE	2	
- 44	815166	• PLATE	1	
- 45	813706	• SCREW,SELF TAPPING- WASH HD 10-32 X 3/8	3	ATT PT
- 46	815217	• BACKPLATE,CLAMP	2	
- 46A	2384	• SCREW,MACH-FIL H 8-32 X 1 IN LG.	4	
- 46B	2102368	• CLAMP,LOOP- 0.880 ID 0.200 DIA MTG HOLE	1	
- 47	5781527	• CLAMP, CABLE-FRONT	2	
- 48	815220	• BAR	1	
- 49	438538	• SCREW,MACH-UNDRCT BIND HD 2-56 X 1/4 LG	2	
- 50	813321	• SPRING,TORSION- 2 RH AND 2 LH FULL TURNS	1	
- 51	815219	• SPACER	2	
- 52	816649	• RETAINER	2	
- 53	815217	• BACKPLATE,CLAMP	1	
- 54	5781828	• BACKPLATE	2	
- 55	2191737	• SCREW, MACHINE	4	ATT PT
- 56	5781840	• SPACER	2	
- 57	815226	• PLATE ASM,0.95-1.50 CABLE BUILD-UP	1	
- 58	815220	• BAR	1	
- 59	815175	• SCREW,CLAMP-HEX SOC HD 8-32 X 2.250 LG	2	
- 60	813321	• SPRING,TORSION- 2 RH AND 2 LH FULL TURNS	1	
- 61	815219	• SPACER	2	
- 62	816649	• RETAINER	2	
- 63	815217	• BACKPLATE,CLAMP	1	

LIST 16. E GATE ASSEMBLY

FIGURE- INDEX NUMBER	PART NUMBER	DESCRIPTION	UNITS PER ASM.	USABLE ON CODE
16 - 64	815214	• PLATE-BACK	1	
- 65	813706	• SCREW,SELF TAPPING- WASH HD 10-32 X 3/8	2	ATT PT
- 66	5781839	• CLAMP-FRONT	1	
- 68	815220	• BAR	1	
- 69	304478	• SCREW,MACH-RH 8-32 X 2-1/2 LG	2	
- 70	813321	• SPRING,TORSION- 2 RH AND 2 LH FULL TURNS	1	
- 71	815219	• SPACER	2	
- 72	816649	• RETAINER	2	
- 73	815217	• BACKPLATE,CLAMP	1	
- 74	5781833	• BACKPLATE CLAMP	1	
- 74A	813706	• SCREW,SELF TAPPING- WASH HD 10-32 X 3/8	2	ATT PT
- 75	327921	• CLAMP,CABLE	2	
- 76	813706	• SCREW,SELF TAPPING- WASH HD 10-32 X 3/8	2	ATT PT
- 76A	2102369	• CLAMP,LOOP- 1.230 ID 0.200 DIA MTG HOLE	1	
- 76B	813706	• SCREW,SELF TAPPING- WASH HD 10-32 X 3/8	1	ATT PT
- 77	815217	• BACKPLATE,CLAMP	1	
- 78	438582	• SCREW,MACH-FIL H 8-32 X 2-1/4 LG	2	ATT PT
- 79	815214	• PLATE-BACK	1	
- 80	813706	• SCREW,SELF TAPPING- WASH HD 10-32 X 3/8	2	ATT PT
- 81	5782283	• BRACKET	4	
- 82	338238	• SCREW,BIND,HD 4-40 X .3125	8	ATT PT
- 83	5781888	• LABEL	1	
- 84	5781845	• GATE ASM-BOARD 2 HIGH OUTER	1	

FOR PARTS
NOT SHOWN
SEE FIG. 12
SHEET 1

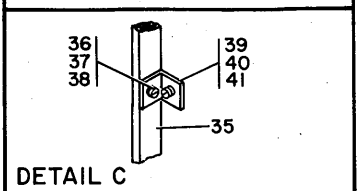
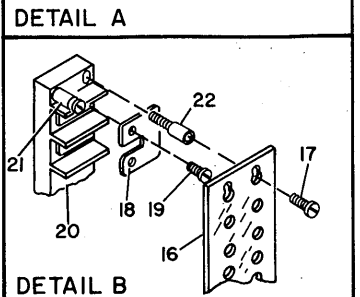
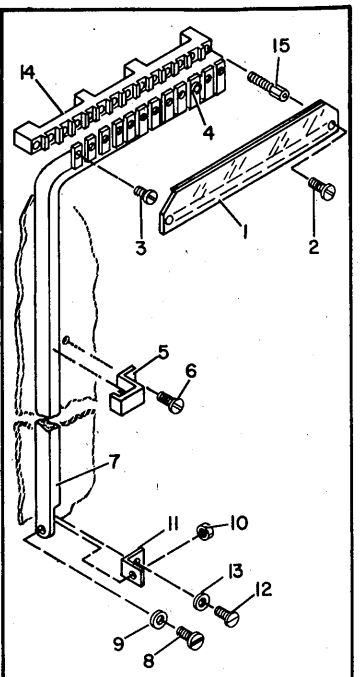
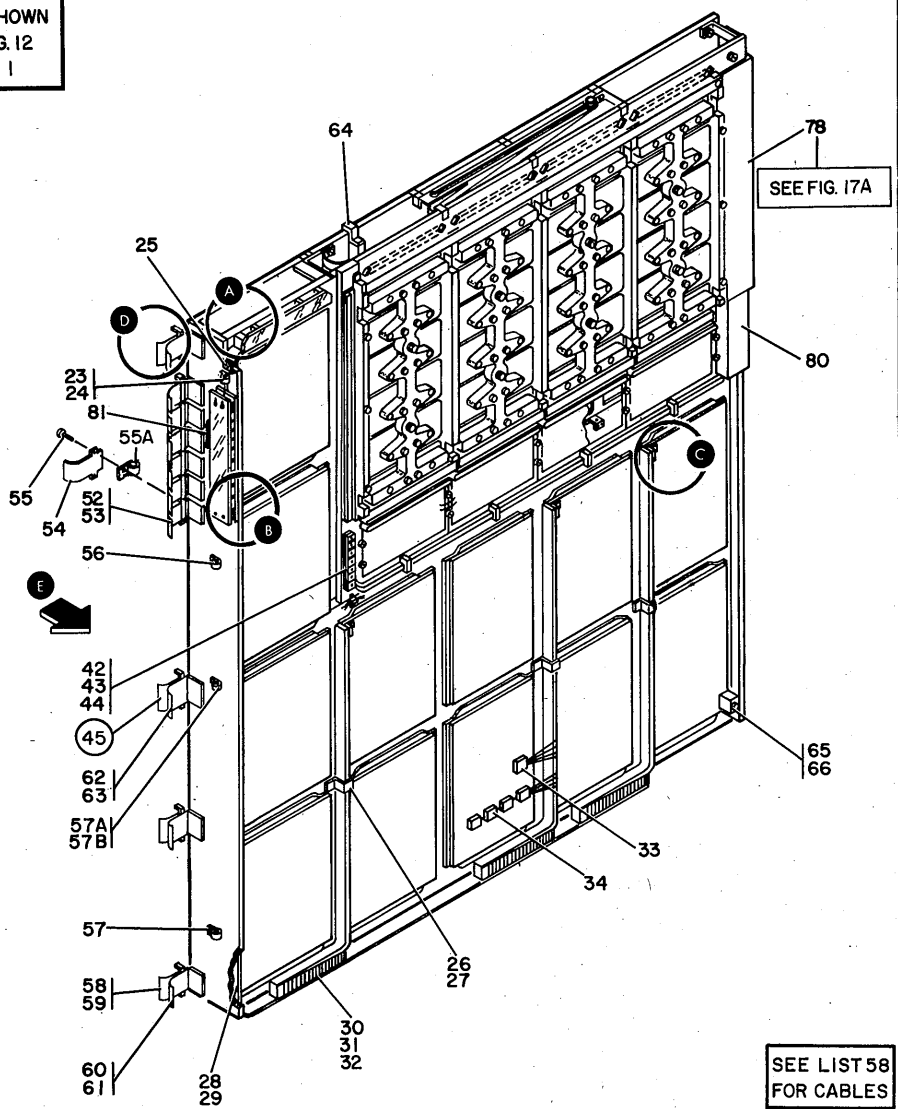

SEE LIST 58
FOR CABLES

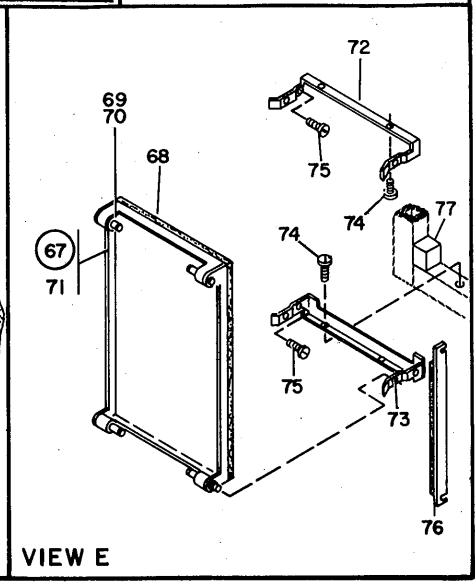
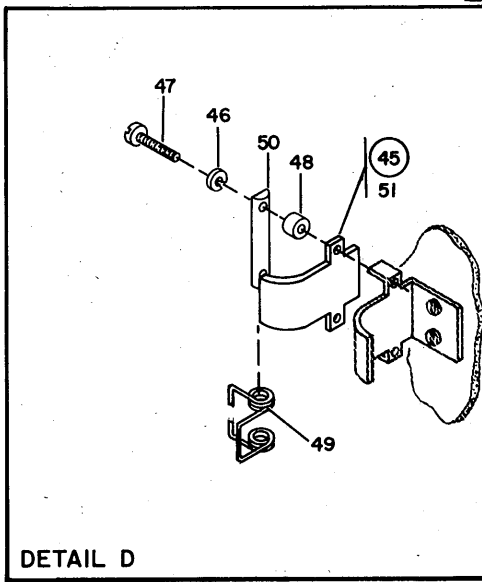

FIGURE 17. C/D GATE ASSEMBLY.

LIST 17. C/D GATE ASSEMBLY

FIGURE- INDEX NUMBER	PART NUMBER	DESCRIPTION	UNITS PER ASM.	USABLE ON CODE
17 -	NO NO.	C/D GATE ASSEMBLY FOR NEXT HIGHER ASM, SEE FIGURE 12-88	NP	
- 1	811556	• COVER ASSEMBLY-FOAM	1	
- 2	10170	• SCREW,MACH-BIND HD 6-32 X 1/4 LG	2	
- 3	34512	• SCREW,BIND,HD 8-32 X .375 LG	12	
- 4	108478	• STUD 8-32	8	
- 5	5703007	• STRAP	2	
- 6	731626	• SCREW, PAN HEAD, 6-32 X .25 LONG	2	
- 7	811530	• BUS ASSEMBLY, VERT., 3 BOARD	1	
- 8	438550	• SCREW,MACH-BIND HD 4-40 X 1/2 LG	1	
- 9	257985	• WASHER,FLAT-NO. 4 X 0.250 OD X 0.028 THK	1	
- 10	37913	• NUT-HEX 4-40 X .250 ID	1	
- 11	811742	• SUPPORT	1	
- 12	811426	• SCREW,MACH-PAN HD 6-32 X 3/8 IN. LG	1	
- 13	257986	• WASHER,FLAT NO. 6	1	
- 14	811476	• TERMINAL BLOCK,BUS TO BUS	1	
- 15	811536	• STANDOFF	2	
- 16	811581	• SHIELD,TERMINAL BOARD	1	
- 17	5312043	• SCREW,MACH-BH 6-32 X 1/4 LG	1	
- 18	5400663	• BUS BAR,2 POSITION	4	
- 19	811481	• SCREW,MACH- 6-32 X 1/4 LG	24	
- 20	811474	• TERMINAL BLOCK ASSEMBLY	1	
- 21	347805	• STUD,SHLDR-8-32 X 3/4 LG THD	3	
- 22	347807	• STUD- 8-32 X 3/4 LG W/6-32 TAPPED HOLE	1	
- 23	327921	• CLAMP,CABLE	3	
- 24	38235	• SCREW,MACH-BIND HD 6-32 X 0.312 LG	3	
- 25	317328	• CHANNEL	AR	
- 26	815946	• STRAP ASSEMBLY-BUS	3	
- 27	811426	• SCREW,MACH-PAN HD 6-32 X 3/8 IN. LG	6	
- 28	811422	• SCREW,HEX H- 8-32 X 0.625 LG	4	
- 29	811515	• BUS ASSEMBLY, HORIZ. GRP 1, 4 BOARD	1	
- 30	811481	• SCREW,MACH- 6-32 X 1/4 LG	36	
- 31	811476	• TERMINAL BLOCK,BUS TO BUS	3	
- 32	38391	• SCREW MACHINE,FIL HD	6	
- 33	811483	• CROSSOVER ASSEMBLY FOR COMPONENT PARTS SEE FIG. 59-50	15	
- 34	813268	• BUS ASM, MINIATURE-7 POSITION	AR	
- 34	813271	• BUS ASM-MINIATURE,8 POSITION FOR COMPONENT PARTS SEE FIG. 59-55	AR	
- 35	811520	• BUS ASSEMBLY, VERT., 2 BOARD	3	
- 36	5356580	• SCREW,MACH-BIND HD 4-40 X 1/2 LG	3	
- 37	815039	• WASHER,FL-NO 4 X 1/8 ID X 1/4 OD	3	
- 38	5373223	• NUT,PLAIN,HEX- 4-40 X 0.250 FL W	3	
- 39	811742	• SUPPORT	3	
- 40	811426	• SCREW,MACH-PAN HD 6-32 X 3/8 IN. LG	3	
- 41	2129550	• WASHER,FLAT- 5/16 OD 5/32 ID 1/32 THK	3	
- 42	2114044	• CLIP,CABLE	AR	
- 43	2114681	• CRADLE-CABLE	AR	
- 44	322550	• SCREW,MACH,BIND HD- 6-32 X .5 LG	AR	
- 45	815226	• PLATE ASM,0.95-1.50 CABLE BUILD-UP	2	
- 46	815210	• RING, RETAINING	2	
- 47	815175	• SCREW,CLAMP-HEX SOC HD 8-32 X 2.250 LG	2	
- 48	815219	• SPACER	2	
- 49	813321	• SPRING,TORSION- 2 RH AND 2 LH FULL TURNS	1	
- 50	815220	• BAR	1	
- 51	815217	• BACKPLATE,CLAMP	1	
- 52	815166	• PLATE	1	
- 53	813706	• SCREW,SELF TAPPING- WASH HD 10-32 X 3/8	3	
- 54	815217	• BACKPLATE,CLAMP	1	
- 55	2384	• SCREW,MACH-FIL H 8-32 X 1 IN LG.	2	
- 55A	2102368	• CLAMP,LOOP- 0.880 ID 0.200 DIA MTG HOLE	1	
- 56	327921	• CLAMP,CABLE	AR	
- 57	356742	• CLAMP,LOOP- 0.250 ID 0.177 DIA MTG HOLE	AR	
- 57A	2102369	• CLAMP,LOOP- 1.230 ID 0.200 DIA MTG HOLE	1	
- 57B	813706	• SCREW,SELF TAPPING- WASH HD 10-32 X 3/8	1	
- 58	815217	• BACKPLATE,CLAMP	1	
- 59	438582	• SCREW,MACH-FIL H 8-32 X 2-1/4 LG	2	
- 60	815214	• PLATE-BACK	3	
- 61	813706	• SCREW,SELF TAPPING- WASH HD 10-32 X 3/8	6	
- 62	815288	• BACKPLATE-CABLE CLAMP GANGED	1	
- 63	813706	• SCREW,SELF TAPPING- WASH HD 10-32 X 3/8	2	
- 64	2573012	• SWITCH ASM	2	
- 65	813179	• CLAMP-BOARD	72	
- 66	811417	• SCREW,HEX SOCKET H- 6-32 X 1/2 LG	72	

LIST 17. C/D GATE ASSEMBLY

FIGURE- INDEX NUMBER	PART NUMBER	DESCRIPTION	UNITS PER ASM.	USABLE ON CODE
17 - 67	811869	• COVER ASSEMBLY-CARD	12	
- 68	815263	• BACKING, FOAM	1	
- 69	815964	• SPACER-HINGE	4	
- 70	815963	• CATCH-PULL	4	
- 71	811868	• COVER-CARD	1	
- 72	811855	• BRACKET-HINGE	12	
- 73	811854	• BRACKET-HINGE	12	
- 74	811426	• SCREW,MACH-PAN HD 6-32 X 3/8 IN. LG USED IN POS. E1, E2 AND E3	ATT PT 12	
- 74	811417	• SCREW,HEX SOCKET H- 6-32 X 1/2 LG USED IN ALL REMAINING POSITIONS	ATT PT 36	
- 75	10170	• SCREW,MACH-BIND HD 6-32 X 1/4 LG USED IN POS. E1, E2 AND E3	ATT PT 12	
- 75	55726	• SCREW,MACH-BIND HD 6-32 X .188 LG USED IN ALL REMAINING POSITIONS	ATT PT 36	
- 76	811881	• RETAINER ASSEMBLY	24	
- 77	811442	• SEAL	24	
- 78	5400799	• CROS MEMORY STORAGE GATE ASSEMBLY FOR DETAIL BREAKDOWN SEE FIGURE 17A	1	
- 80	5353146	• BOARD,GATE	1	

FOR PARTS
NOT SHOWN
SEE FIG. 17

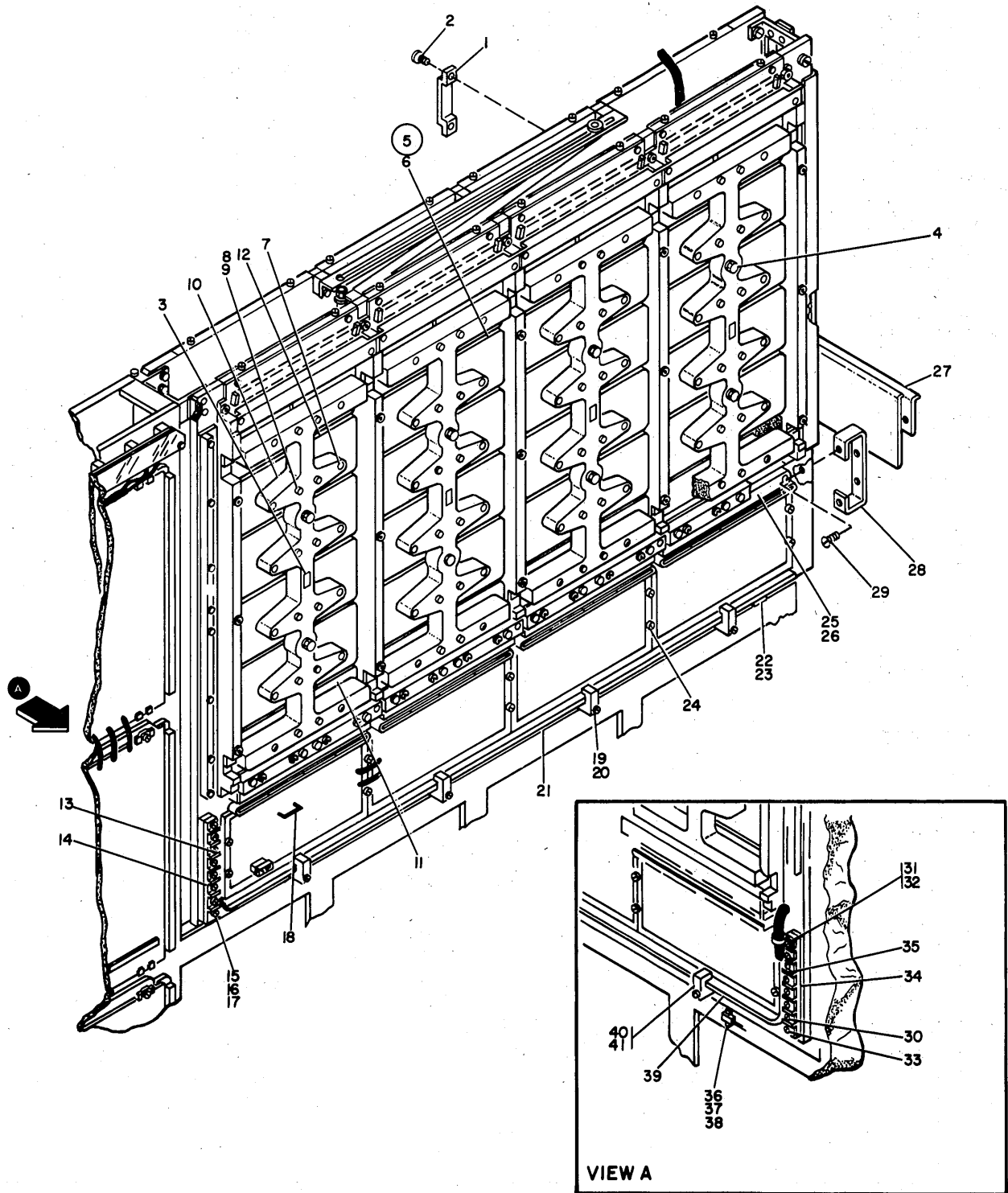

FIGURE 17A. CROS MEMORY STORAGE ASSEMBLY. (SHEET 1 OF 2, INDEX NOS. 1-41)

LIST 17A. CROS MEMORY STORAGE ASSEMBLY

FIGURE- INDEX NUMBER	PART NUMBER	DESCRIPTION	UNITS PER ASM.	USABLE ON CODE
		1 2 3 4		
17A-	5400799	CROS MEMORY STORAGE GATE ASSEMBLY FOR NEXT HIGHER ASM, SEE FIGURE 17-78	REF	
- 1	5703328	. BUMPER,GATE	1	
- 2	322550	. SCREW,MACH,BIND HD- 6-32 X .5 LG	2	
- 3	811825	. LABEL-CABLE	16	
- 4	5400689	. NUT,ROUND-KNURLED	32	
- 5	5702960	. SPIDER ASM	16	
- 6	33370	. SCREW,MACH-HEX HD 8-32 X 13/16 LG	64	
- 7	58865	. SETSCREW-HDLS SPLINE DR 10-32 X 7/8 LG	12	
- 8	5703279	. SPRING	12	
- 9	438553	. SCREW,MACH-BIND HD 4-40 X 7/8 LG	12	
- 10	5702957	. SPIDER	1	
- 11	5702958	. PLATE	2	
- 12	5702959	. PLATE	10	
- 13	811481	. SCREW,MACH- 6-32 X 1/4 LG	6	
- 14	5400745	. JUMPER,BUS 3 POSITION	2	
- 15	5702977	. TERMINAL BOARD ASM-7 POS	1	
- 16	438587	. SCREW,MACH-BIND HD 8-32 X 1-1/8 LG	2	
- 17	5702978	. SPACER	1	
- 18	815080	. STRAP	40	
- 19	5702976	. CLAMP-BUS BAR	8	
- 20	438547	. SCREW,MACH-FIL H 4-40 X 1-1/4 LG	8	
- 21	5702973	. BUS BAR	1	
- 22	5703276	. SUPPORT	1	
- 23	25627	. SCREW-BD. HD 8-32 X .500 LG	2	
- 24	438551	. SCREW,MACH-BIND HD 4-40 X 5/8 LG	16	
- 25	5703009	. CLAMP	16	
- 26	438551	. SCREW,MACH-BIND HD 4-40 X 5/8 LG	32	
- 27	5702990	. RETAINER ASM-DRIVE CARD	8	
- 28	5702987	. BRACKET	10	
- 29	438552	. SCREW,MACH-BIND HD 4-40 X 3/4 LG	20	
- 30	811481	. SCREW,MACH- 6-32 X 1/4 LG	6	
- 31	2102367	. CLAMP-LOOP	1	
- 32	438589	. SCREW,MACH-BIND HD 8-32 X 1-1/2 LG	1	
- 33	438588	. SCREW,MACH-UNDRCT BIND HD 8-32 X 1-1/4	1	
- 34	5702977	. TERMINAL BOARD ASM-7 POS	1	
- 35	5702978	. SPACER	1	
- 36	2114044	. CLIP,CABLE	1	
- 37	2114681	. CRADLE-CABLE	1	
- 38	322550	. SCREW,MACH,BIND HD- 6-32 X .5 LG	1	
- 39	5702975	. BUS BAR	1	
- 40	5703155	. SUPPORT	1	
- 41	25627	. SCREW-BD. HD 8-32 X .500 LG	2	

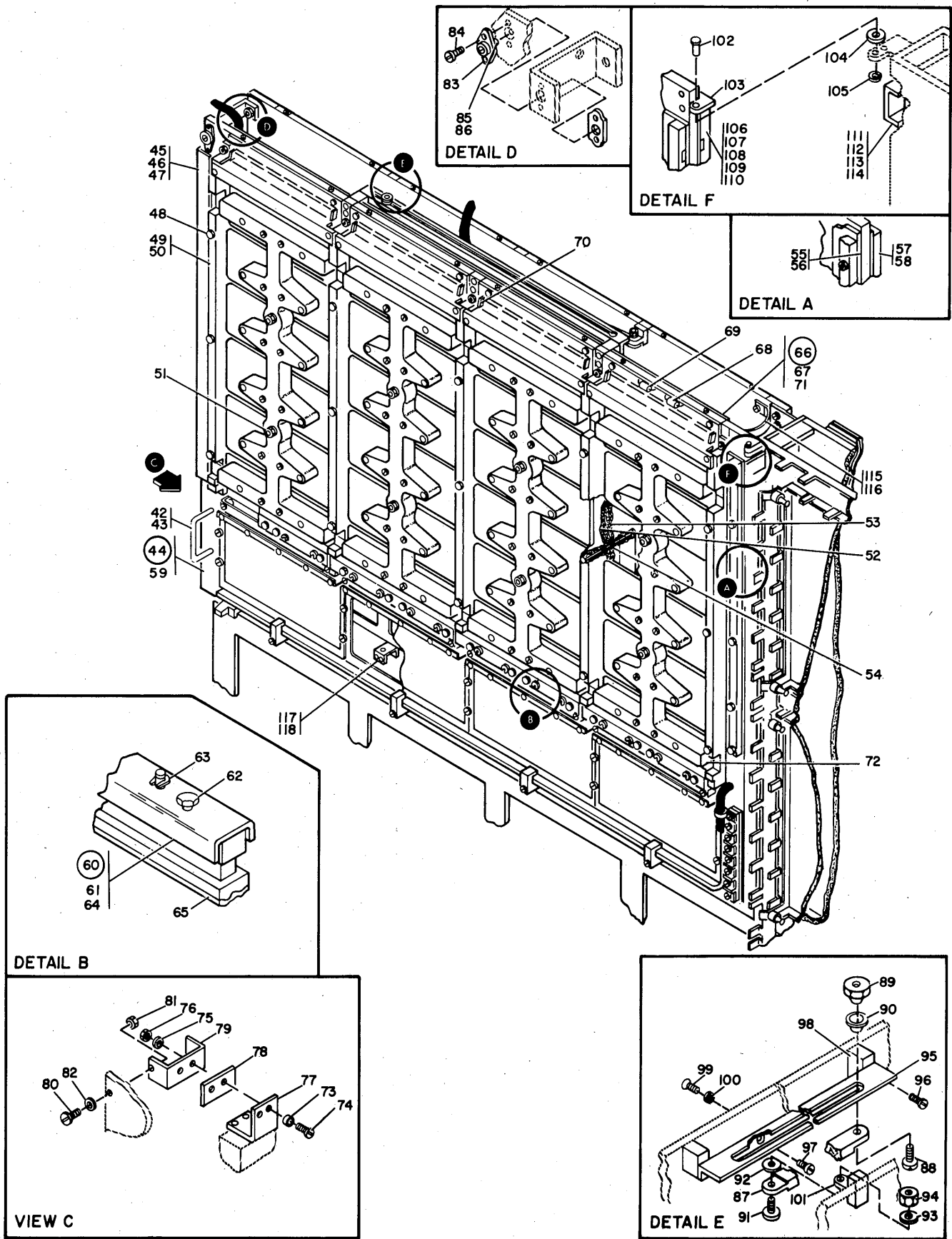
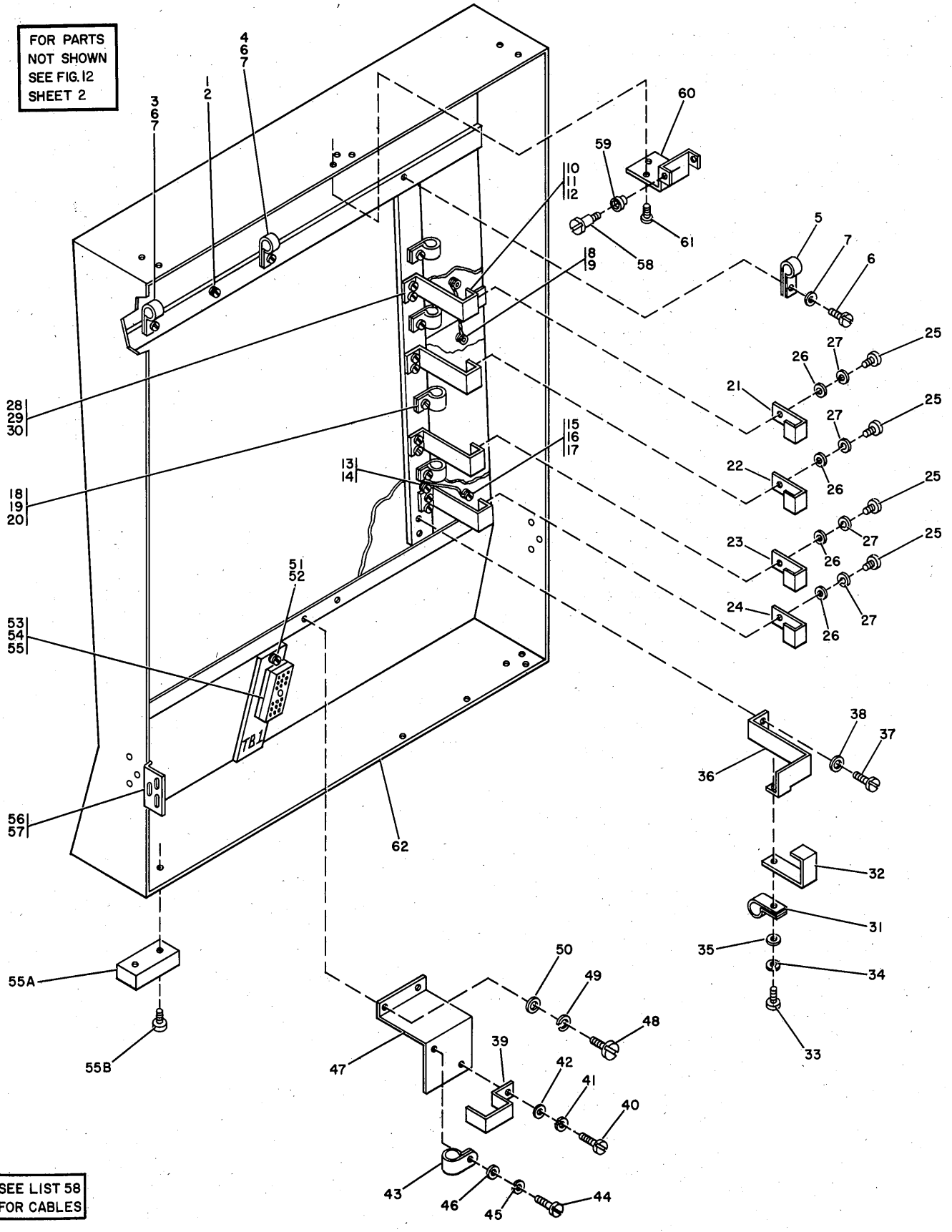

FIGURE 17A. CROS MEMORY STORAGE ASSEMBLY. (SHEET 2 OF 2, INDEX NOS. 42-118)

LIST 17A. GROS MEMORY STORAGE ASSEMBLY

FIGURE- INDEX NUMBER	PART NUMBER	DESCRIPTION	UNITS PER ASM.	USABLE ON CODE
17A- 42	319300	. HANDLE	1	
- 43	55918	. SCREW, MACH-BIND HD 10-32 X 5/8 LG	2	
- 44	5408113	. BASE PLANE ASSEMBLY	2	
- 45	5400666	. SHIELD-SENSE RESISTOR	1	
- 46	438550	. SCREW, MACH-BIND HD 4-40 X 1/2 LG	3	
- 47	257985	. WASHER, FLAT-NO. 4 X 0.250 OD X 0.028 THK	3	
- 48	5400656	. STUD, VERTICAL BAR	10	
- 49	5400657	. VERTICAL BAR	10	
- 50	257189	. NUT, HEX- 8-32	50	
- 51	5702968	. STUD	23	
- 52	5408095	. SENSE PLATE ASM, A&D	1	
- 53	5408090	. SENSE PLATE ASM, A&C	1	
- 54	1144956	. PAD-PIN BACKSTOP	AR	
- 55	5408097	. CONNECTOR, SENSE-72 POSITION	5	
- 56	438538	. SCREW, MACH-UNDRCT BIND HD 2-56 X 1/4 LG	12	
- 57	5408098	. CONNECTOR, SENSE-42 POSITION	1	
- 58	15887	. SCREW, MACH-BIND HD 2-56 X 1/8 LG	12	
- 59	5408084	. BASE PLATE	1	
- 60	5400658	. CONNECTOR ASSEMBLY-DRIVE	32	
- 61	38354	. SCREW, MACH-FIL H 6-32 X 1/2 LG	64	
- 62	5400655	. SCREW, PRESSURE DRIVE CONNECTOR	4	
- 63	147297	. RING, RETAINING-EXT 0.094 ID X 0.020 THK	4	
- 64	5400648	. CHANNEL, DRIVE CONNECTOR	1	
- 65	5400650	. CONNECTOR ASSEMBLY, DRIVE-PRESSURE UNIT	2	
- 66	5400781	. RESISTOR ASSEMBLY	16	
- 67	48594	. SCREW, MACH-BIND HD 6-32 X 0.250 LG	32	
- 68	124582	. CAPACITOR FXD TANTALUM	2	
- 69	383608	. CAPACITOR-TANTALUM 6.2MFD P 80 M 20% 25V	1	
- 70	5703052	. MODULE, RC NETWORK	22	
- 71	5400778	. BOARD C13, DRIVE RESISTOR	1	
- 72	5702966	. SPONGE, SHEET	16	
- 73	5703002	. BUSHING	2	
- 74	322028	. SCREW, MACH-BIND HD 1/4-20 X 3/4 LG	2	
- 75	76574	. LOCKWASHER-EXT TOOTH ID .267 X OD .510	2	
- 76	3960	. NUT, PLAIN, HEX- 1/4-20 X 7/16 FL W	2	
- 77	5400662	. BRACKET	1	
- 78	5400661	. SPACER, INSULATION	1	
- 79	5702998	. BRACKET ASM-GATE FASTENER	2	
- 80	110286	. SCREW-MACHINE	2	
- 81	55586	. NUT, CHECK, HEX-1/4-20 X 1/8 FL W	2	
- 82	5703006	. SPACER	2	
- 83	5702995	. GROMMET	2	
- 84	236550	. SCREW, MACH-BIND HD 4-40 X 0.375 LG	4	
- 85	5702996	. STUD-WING HD	2	
- 86	244111	. WASHER, STUD RETAINING-CAMLOC	2	
- 87	5703285	. ARM, BASE PLATE	1	
- 88	32617	. SCREW, MACH-BIND HD 10-32 X 0.438 LG	1	
- 89	5703286	. NUT, SHOULDER	1	
- 90	5703282	. ROLLER-ARM	1	
- 91	234565	. SCREW, SHOULDER LATCH	1	
- 92	22478	. WASHER, FL- 0.170 ID 0.375 OD 0.32 THK	1	
- 93	1090873	. WASHER, LOCK, SPLIT RING- .168 ID, .296 OD	1	
- 94	257189	. NUT, HEX- 8-32	1	
- 95	5703284	. GUIDE, ARM	1	
- 96	38352	. SCREW, MACH-FIL H 6-32 X 3/8 LG	2	
- 97	38443	. SCREW, MACH-FL CSK HD 6-32 X 5/16 LG	1	
- 98	5703283	. BLOCK, MOUNTING-GUIDE	3	
- 99	5644	. SCREW, MACH-FIL H 6-32 X 5/8 LG	8	
- 100	6364	. WASHER, LOCK-SPLIT NO. 6 X 1/4 OD	8	
- 101	5703287	. BLOCK, MOUNTING, ARM	1	
- 102	5703000	. PIN	2	
- 103	5702999	. HINGE	2	
- 104	161351	. WASHER, PLAIN FLAT	1	
- 105	332747	. RING, RETAINING-EXT 0.207 ID X 0.025 THK	2	
- 106	5703001	. BUSHING	4	
- 107	38688	. SCREW-SUPPORT & TRIM MOUNTING .750 LONG	4	
- 108	6935	. WASHER, LOCK-SPLIT 1/4 X 0.493 OD	4	
- 109	3550	. WASHER, FL- 1/4 X 9/16 OD X 0.050 THK	4	
- 110	5703004	. SPACER	2	
- 111	5703154	. CLAMP ASM-CABLE	5	
- 112	322065	. SCREW, MACH-BIND HD 6-32 X 5/8 LG	10	
- 113	62031	. WASHER, LOCK-INT TEETH NO. 6 X 0.295 OD	10	
- 114	257986	. WASHER, FLAT NO. 6	10	
- 115	5400675	. STRIP ASSEMBLY, GROUND	2	
- 116	34512	. SCREW, BIND HD 8-32 X .375 LG	4	
- 117	5703008	. BRACKET	8	
- 118	338238	. SCREW, MACH-BD HD 4-40 NC X .3125 LG	16	

FOR PARTS
NOT SHOWN
SEE FIG. 12
SHEET 2



SEE LIST 58
FOR CABLES

FIGURE 18. CPU PANEL ASSEMBLY.

LIST 18. CPU PANEL ASSEMBLY

FIGURE- INDEX NUMBER	PART NUMBER	DESCRIPTION	UNITS PER ASM.	USABLE ON CODE
18 -	5781329	CPU PANEL ASSEMBLY FOR NEXT HIGHER ASM, SEE FIGURE 12-107	REF	
- 1	34512	. SCREW,BIND.HD 8-32 X .375 LG	1	
- 2	55901	. WASHER,LOCK-EXT TEETH NO. 8 X 0.381 OD	1	
- 3	595704	. CLAMP	1	
- 4	327921	. CLAMP,CABLE	1	
- 5	327923	. CLAMP,LOOP	1	
- 6	34512	. SCREW,BIND.HD 8-32 X .375 LG	3	ATT PT
- 7	22478	. WASHER,FL- 0.170 ID 0.375 OD 0.32 THK	3	ATT PT
- 8	257189	. NUT,HEX- 8-32	1	
- 9	55901	. WASHER,LOCK-EXT TEETH NO. 8 X 0.381 OD	1	
- 10	5781835	. PLATE	1	
- 11	257189	. NUT,HEX- 8-32	4	ATT PT
- 12	55901	. WASHER,LOCK-EXT TEETH NO. 8 X 0.381 OD	4	ATT PT
- 13	34512	. SCREW,BIND.HD 8-32 X .375 LG	1	
- 14	55901	. WASHER,LOCK-EXT TEETH NO. 8 X 0.381 OD	1	
- 15	5759502	. JUMPER ASM FOR COMPONENT PARTS,SEE FIG. 59-36F	1	
- 16	257189	. NUT,HEX- 8-32	1	ATT PT
- 17	55901	. WASHER,LOCK-EXT TEETH NO. 8 X 0.381 OD	1	ATT PT
- 18	327923	. CLAMP,LOOP	4	
- 19	34512	. SCREW,BIND.HD 8-32 X .375 LG	4	ATT PT
- 20	22478	. WASHER,FL- 0.170 ID 0.375 OD 0.32 THK	4	ATT PT
- 21	5276594	. CLAMP,CABLE	1	
- 22	5276593	. CLAMP,CABLE	1	
- 23	5276592	. CLAMP,CABLE	1	
- 24	5276591	. CLAMP,CABLE	1	
- 25	25627	. SCREW-BD. HD 8-32 X .500 LG	4	ATT PT
- 26	22478	. WASHER,FL- 0.170 ID 0.375 OD 0.32 THK	4	ATT PT
- 27	1090873	. WASHER,LOCK,SPLIT RING- .168 ID, .296 OD	4	ATT PT
- 28	5276588	. BRACKET,CABLE SUPPORT	4	
- 29	58207	. SCREW,MACH-UNDRCT BIND HD 8-32 X 1/4 LG	8	ATT PT
- 30	22478	. WASHER,FL- 0.170 ID 0.375 OD 0.32 THK	8	ATT PT
- 31	327923	. CLAMP,LOOP	1	
- 32	5276590	. CLAMP,CABLE	1	
- 33	25627	. SCREW-BD. HD 8-32 X .500 LG	1	ATT PT
- 34	1090873	. WASHER,LOCK,SPLIT RING- .168 ID, .296 OD	1	ATT PT
- 35	22478	. WASHER,FL- 0.170 ID 0.375 OD 0.32 THK	1	ATT PT
- 36	5276587	. BRACKET,CABLE SUPPORT	1	
- 37	58207	. SCREW,MACH-UNDRCT BIND HD 8-32 X 1/4 LG	2	ATT PT
- 38	22478	. WASHER,FL- 0.170 ID 0.375 OD 0.32 THK	2	ATT PT
- 39	5276595	. CLAMP,CABLE	1	
- 40	25627	. SCREW-BD. HD 8-32 X .500 LG	1	ATT PT
- 41	1090873	. WASHER,LOCK,SPLIT RING- .168 ID, .296 OD	1	ATT PT
- 42	22478	. WASHER,FL- 0.170 ID 0.375 OD 0.32 THK	1	ATT PT
- 43	534768	. CLAMP,CABLE	1	
- 44	25627	. SCREW-BD. HD 8-32 X .500 LG	1	ATT PT
- 45	1090873	. WASHER,LOCK,SPLIT RING- .168 ID, .296 OD	1	ATT PT
- 46	22478	. WASHER,FL- 0.170 ID 0.375 OD 0.32 THK	1	ATT PT
- 47	5276589	. BRACKET	1	
- 48	32617	. SCREW,MACH-BIND HD 10-32 X 0.438 LG	2	ATT PT
- 49	9092	. WASHER-LOCK,SPLIT RING, .194 ID .337OD	2	ATT PT
- 50	45690	. WASHER, FL - NO.10 X 7/16 OD X 1/32 THK	2	ATT PT
- 51	34512	. SCREW,BIND.HD 8-32 X .375 LG	1	
- 52	55901	. WASHER,LOCK-EXT TEETH NO. 8 X 0.381 OD	1	
- 53	302090	. CONNECTOR,RECP,ELEC- 24 FEMALE CONTACTS	1	
- 54	438550	. SCREW,MACH-BIND HD 4-40 X 1/2 LG	1	ATT PT
- 55	302131	. INSULATOR,TERMINAL BLOCK	1	
- 55A	5372714	. SLIDE,CONSOLE	2	
- 55B	34512	. SCREW,BIND.HD 8-32 X .375 LG	4	ATT PT
- 56	5372715	. BRACKET,DOUBLE ANGLE,CONSOLE MOUNTING	2	
- 57	236849	. SCREW,MACH-BIND HD 10-32 X 0.250 LG	6	ATT PT
- 58	144424	. SCREW	2	
- 59	226027	. HUB	2	
- 60	5372713	. BRACKET,MOUNTING,ROLLER	1	
- 61	28413	. SCREW,MACH-BIND HD 10-32 X 5/16 LG	3	ATT PT
- 62	5781372	. CE PANEL	1	

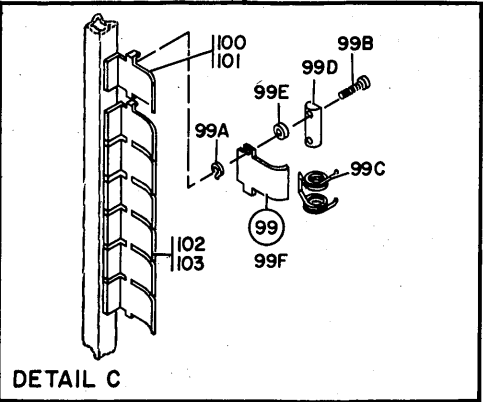
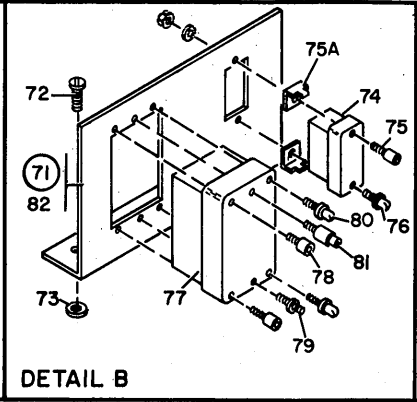
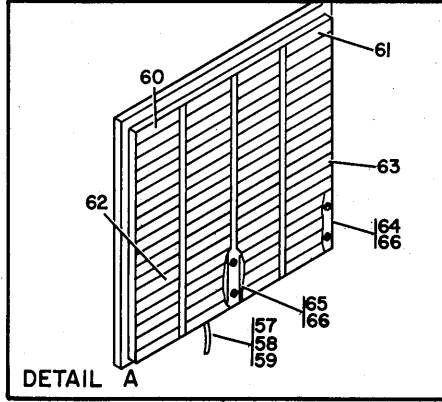
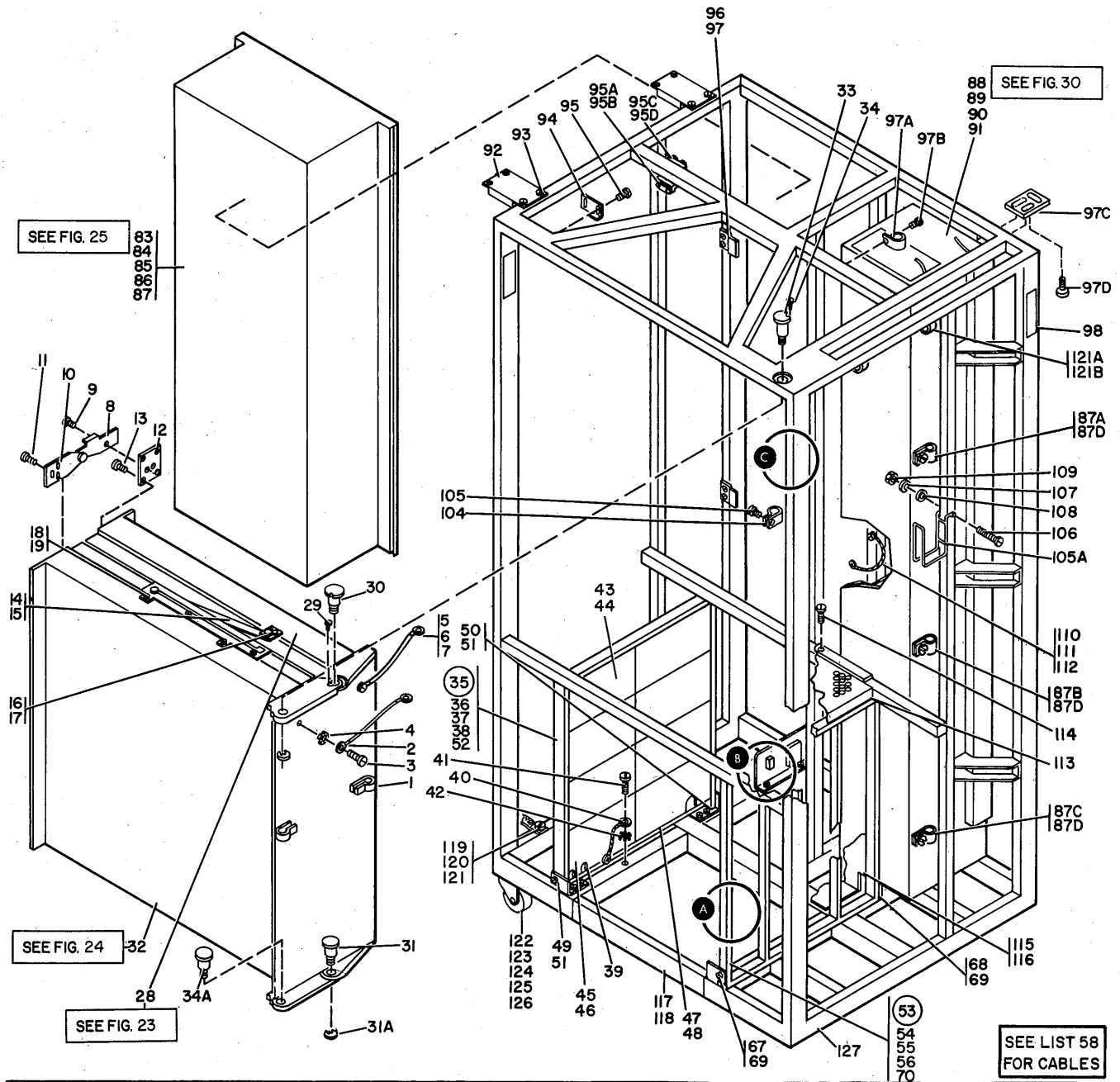

FIGURE 22. DAT FRAME ASSEMBLY.

LIST 22. DAT FRAME ASSEMBLY

FIGURE- INDEX NUMBER	PART NUMBER	DESCRIPTION	UNITS PER ASM.	USABLE ON CODE
22 -	5781302	FRAME ASM-DAT	REF	
- 1	327922	. CLAMP, CABLE-.625 DIAMETER	2	
- 2	5820575	. JUMPER ASM	1	
		FOR COMPONENT PARTS SEE FIG. 59-34A		
- 3	32042	. SCREW, MACH BIND. HD 10-32 X 3/8 LG.	2	ATT PT
- 4	56079	. WASHER, LOCK-EXT T .195 ID .410 OD	2	ATT PT
- 5	5820582	. JUMPER ASM	1	
		FOR COMPONENT PARTS SEE FIG. 59-34A		
- 6	32042	. SCREW, MACH BIND. HD 10-32 X 3/8 LG.	2	ATT PT
- 7	56079	. WASHER, LOCK-EXT T .195 ID .410 OD	2	ATT PT
- 8	5722062	. LATCH-INNER GATE	1	
- 9	5722064	. PIN-LATCH	2	ATT PT
- 10	5722061	. CATCH-INNER GATE	1	
- 11	32042	. SCREW, MACH BIND. HD 10-32 X 3/8 LG.	3	ATT PT
- 12	5722063	. BRACKET-LATCH MTG	1	
- 13	99	. SCREW, MACH-FL CSK HD 10-32 X 3/8 LG	4	ATT PT
- 14	5722044	. ARM-STAYBRACE	1	
- 15	5722045	. PIN-STAYBRACE	2	ATT PT
- 16	5722046	. BRACKET	1	
- 17	5349929	. SCREW-THREAD FORMING HEX WASHER HEAD	2	ATT PT
- 18	5722043	. GUIDE-STAYBRACE	1	
- 19	5349929	. SCREW-THREAD FORMING HEX WASHER HEAD	4	ATT PT
- 28	5781314	. L GATE ASSEMBLY	1	
		FOR DETAIL BREAKDOWN SEE FIGURE 23		
- 29	32042	. SCREW, MACH BIND. HD 10-32 X 3/8 LG.	1	ATT PT
- 30	5781889	. PIN-HINGE	1	ATT PT
- 31	5722067	. PIN-HINGE-INNER GATE	1	ATT PT
- 31A	2156671	. RING-RETAINING	2	ATT PT
- 32	5781315	. K GATE ASSEMBLY	1	
		FOR DETAIL BREAKDOWN SEE FIGURE 24		
- 33	5353026	. PIN-HINGE	1	ATT PT
- 34	32042	. SCREW, MACH BIND. HD 10-32 X 3/8 LG.	1	ATT PT
- 34A	5722066	. PIN-HINGE-OUTER GATE	1	ATT PT
- 35	5781339	. I/O PANEL ASM-DUMMY	1	
- 36	32042	. SCREW, MACH BIND. HD 10-32 X 3/8 LG.	5	ATT PT
- 37	322061	. SCREW, MACH-BIND HD 10-32 X 1-1/4 LG	2	ATT PT
- 38	56079	. WASHER, LOCK-EXT T .195 ID .410 OD	1	ATT PT
- 39	730432	. GROMMET, CATERPILLAR	4	
- 40	5759216	. JUMPER ASM	1	
		FOR COMPONENT PARTS SEE FIG. 59-37A		
- 41	32042	. SCREW, MACH BIND. HD 10-32 X 3/8 LG.	1	ATT PT
- 42	56079	. WASHER, LOCK-EXT T .195 ID .410 OD	1	ATT PT
- 43	5781497	. PLATE-BLANK I/O	6	
- 44	10170	. SCREW, MACH-BIND HD 6-32 X 1/4 LG	18	ATT PT
- 45	5781499	. PLATE, ADAPTER	1	
- 46	10170	. SCREW, MACH-BIND HD 6-32 X 1/4 LG	4	ATT PT
- 47	5781498	. PLATE LINE CORD	1	
- 48	10170	. SCREW, MACH-BIND HD 6-32 X 1/4 LG	2	ATT PT
- 49	5781357	. SUPPORT-I/O PANEL LEFT SIDE	1	
- 50	5781358	. SUPPORT-I/O PANEL RIGHT SIDE	1	
- 51	32042	. SCREW, MACH BIND. HD 10-32 X 3/8 LG.	2	ATT PT
- 52	5781354	. I/O PANEL	1	
- 53	5781328	. I/O PANEL	1	
- 54	32042	. SCREW, MACH BIND. HD 10-32 X 3/8 LG.	5	ATT PT
- 55	322061	. SCREW, MACH-BIND HD 10-32 X 1-1/4 LG	2	ATT PT
- 56	56079	. WASHER, LOCK-EXT T .195 ID .410 OD	1	ATT PT
- 57	5759216	. JUMPER ASM	1	
		FOR COMPONENT PARTS SEE FIG. 59-37A		
- 58	32042	. SCREW, MACH BIND. HD 10-32 X 3/8 LG.	1	ATT PT
- 59	56079	. WASHER, LOCK-EXT T .195 ID .410 OD	1	ATT PT
- 60	5362305	. CONNECTOR ASSEMBLY, B STYLE	2	
- 61	5362304	. CONNECTOR ASSEMBLY, A STYLE	74	
- 62	5769671	. CONNECTOR ASM	2	
- 63	5728787	. CONNECTOR ASSEMBLY	2	
- 64	5781356	. KEEPER-CONN END	8	
- 65	5781355	. KEEPER-CONN MIDDLE	12	
- 66	38350	. SCREW, MACH-FIL H 6-32 X 1/4 LG	40	ATT PT
- 67	5781357	. SUPPORT-I/O PANEL LEFT SIDE	1	
- 68	5781358	. SUPPORT-I/O PANEL RIGHT SIDE	1	
- 69	32042	. SCREW, MACH BIND. HD 10-32 X 3/8 LG.	2	ATT PT
- 70	5781354	. I/O PANEL	1	

LIST 22. DAT FRAME ASSEMBLY

FIGURE- INDEX NUMBER	PART NUMBER	DESCRIPTION	UNITS PER ASM.	USABLE ON CODE
22 -	71	5781567		
- 71		. PANEL ASSEMBLY	1	
- 72	32042	. SCREW, MACH BIND. HD 10-32 X 3/8 LG.	2	ATT PT
- 73	56079	. WASHER, LOCK-EXT T .195 ID .410 OD	2	ATT PT
- 74	2122837	. CONNECTOR, PLUG, ELECTRICAL, FEMALE	1	
- 75	2122202	. SOCKET, GUIDE-CENTER	1	ATT PT
- 75A	2127987	. CATCH CLIP	2	
- 76	2122203	. PIN, GUIDE, BRASS, / SUPPLIED W/HARDWARE/	1	ATT PT
- 77	2122626	. BLOCK, MALE- 104 POS MINIATURE CONNECTOR	1	
- 78	2122636	. SOCKET, GUIDE-CORNER 75 AND 104 POS CONN	2	ATT PT
- 79	2123029	. JACKSCREW-STUD, FIXED	1	ATT PT
- 80	2122637	. PIN, GUIDE CORNER	2	ATT PT
- 81	2123028	. JACK SCREW, SOCKET, FIXED	1	ATT PT
- 82	5781565	. BRACKET-CONN MTG	1	
- 83	5703200	. 75 AMP CONVERTER INVERTER ASM	1	
		FOR DETAIL BREAKDOWN SEE FIGURE 25		
- 84	36844	. SCREW, CAP-HEX HD SLOTTED 1/4-20 X 5/8 LG	2	ATT PT
- 85	322029	. SCREW, MACH-BIND HD 1/4-20 X 1/2 LG	2	ATT PT
- 86	6935	. WASHER, LOCK-SPLIT 1/4 X 0.493 OD	6	ATT PT
- 87	5366635	. STUD	2	ATT PT
- 87A	327922	. CLAMP, CABLE-.625 DIAMETER	1	
- 87B	327923	. CLAMP, LOOP	1	
- 87C	327921	. CLAMP, CABLE	1	
- 87D	32042	. SCREW, MACH BIND. HD 10-32 X 3/8 LG.	3	ATT PT
- 88	5781311	. POWER TUB ASSEMBLY	1	
		FOR DETAIL BREAKDOWN SEE FIGURE 30		
- 89	36844	. SCREW, CAP-HEX HD SLOTTED 1/4-20 X 5/8 LG	6	ATT PT
- 90	6935	. WASHER, LOCK-SPLIT 1/4 X 0.493 OD	6	ATT PT
- 91	3550	. WASHER, FL- 1/4 X 9/16 OD X 0.050 THK	6	ATT PT
- 92	5372797	. BRACKET	4	
- 93	32042	. SCREW, MACH BIND. HD 10-32 X 3/8 LG.	16	ATT PT
- 94	5722049	. CATCH-GATE STOP	1	
- 95	32042	. SCREW, MACH BIND. HD 10-32 X 3/8 LG.	2	ATT PT
- 95A	5353107	. BUMPER, GATE	1	
- 95B	34512	. SCREW, BIND. HD 8-32 X .375 LG	2	ATT PT
- 95C	5781886	. BRACKET- GATE STOP	1	
- 95D	32042	. SCREW, MACH BIND. HD 10-32 X 3/8 LG.	2	ATT PT
- 96	5722018	. BRACKET-MTG	3	
- 97	32042	. SCREW, MACH BIND. HD 10-32 X 3/8 LG.	6	ATT PT
- 97A	327921	. CLAMP, CABLE	3	
- 97B	332620	. SCREW, MACH-BIND HD 10-32 X 1/2 LG	3	ATT PT
- 97C	5421373	. STRIKE	1	
- 97D	32042	. SCREW, MACH BIND. HD 10-32 X 3/8 LG.	2	ATT PT
- 98	2569395	. LABEL-WARNING	1	
- 99	815225	. PLATE ASM, 0.44-0.94 CABLE BUILD-UP	7	
- 99A	815210	. RING, RETAINING	2	
- 99B	815174	. SCREW, CLAMP-HEX SOC HD 8-32 X 1.750 LG	2	
- 99C	813321	. SPRING, TORSION- 2 RH AND 2 LH FULL TURNS	1	
- 99D	815220	. BAR	1	
- 99E	815219	. SPACER	2	
- 99F	815217	. BACKPLATE, CLAMP	1	
- 100	815171	. BACKPLATE, CABLE CLAMP	1	
- 101	32042	. SCREW, MACH BIND. HD 10-32 X 3/8 LG.	2	ATT PT
- 102	815170	. BACKPLATE	1	
- 103	32042	. SCREW, MACH BIND. HD 10-32 X 3/8 LG.	4	ATT PT
- 104	1127180	. CLAMP, LOOP- 1-1/8 ID 0.199 MTG HOLE	1	
- 105	32042	. SCREW, MACH BIND. HD 10-32 X 3/8 LG.	1	ATT PT
- 105A	5781363	. HANGER-CABLE	18	
- 106	106419	. SCREW, MACH-BIND HD 10-32 X 1-3/4 LG	18	ATT PT
- 107	9092	. WASHER-LOCK, SPLIT RING, .194 ID .337 OD	18	ATT PT
- 108	45690	. WASHER, FL - NO.10 X 7/16 OD X 1/32 THK	18	ATT PT
- 109	11598	. NUT, PLAIN-HEX 10-32 X 3/8 FL W	18	ATT PT
- 110	5236967	. JUMPER ASM-GRN/YEL 6 IN. 10AWG 1 LUG EA	1	
		FOR COMPONENT PARTS SEE FIG. 59-34A		
- 111	34512	. SCREW, BIND. HD 8-32 X .375 LG	1	ATT PT
- 112	55901	. WASHER, LOCK-EXT TEETH NO. 8 X 0.381 OD	1	ATT PT
- 113	5781410	. SCREEN-TOP I/O	1	
- 114	32042	. SCREW, MACH BIND. HD 10-32 X 3/8 LG.	6	ATT PT
- 115	5781409	. COVER-VERTICAL	1	
- 116	32042	. SCREW, MACH BIND. HD 10-32 X 3/8 LG.	9	ATT PT
- 117	5781359	. RETAINER-CABLE	1	
- 118	32042	. SCREW, MACH BIND. HD 10-32 X 3/8 LG.	4	ATT PT
- 119	5240500	. STRAP	1	
- 120	32042	. SCREW, MACH BIND. HD 10-32 X 3/8 LG.	1	ATT PT
- 121	56079	. WASHER, LOCK-EXT T .195 ID .410 OD	1	ATT PT
- 121A	327923	. CLAMP, LOOP	2	
- 121B	32042	. SCREW, MACH BIND. HD 10-32 X 3/8 LG.	2	ATT PT
- 122	252632	. CASTER	4	
- 123	38686	. SCREW, MACH-HEX HD 1/4-20 X 1/2 LG	15	ATT PT
- 124	38688	. SCREW-SUPPORT & TRIM MOUNTING .750 LONG	1	ATT PT
- 125	76574	. LOCKWASHER-EXT TOOTH ID .267 X OD .510	1	ATT PT
- 126	36109	. NUT, PLAIN, HEX- 1/4-20 X 7/16 FL W	1	ATT PT
- 127	5781360	. DAT FRAME	1	

FOR PARTS
NOT SHOWN
SEE FIG. 22

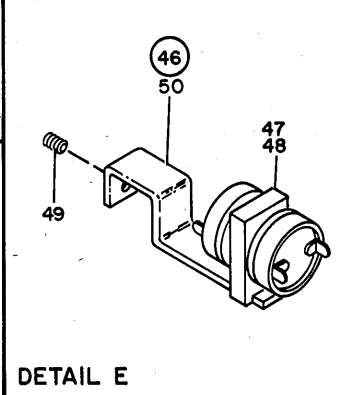
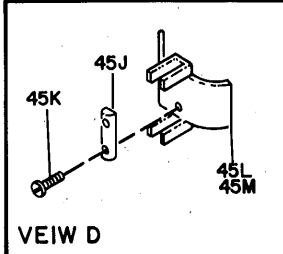
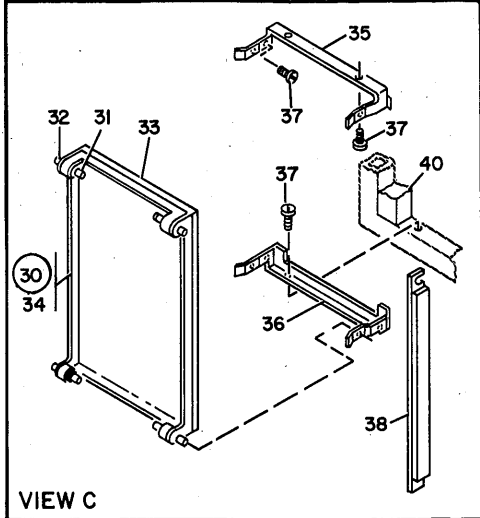
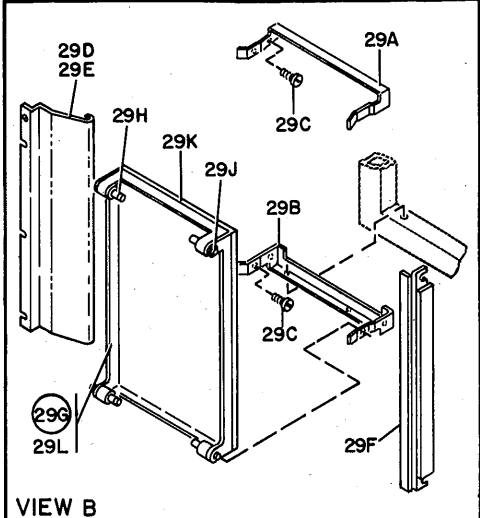
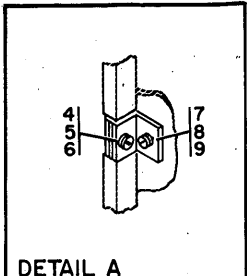
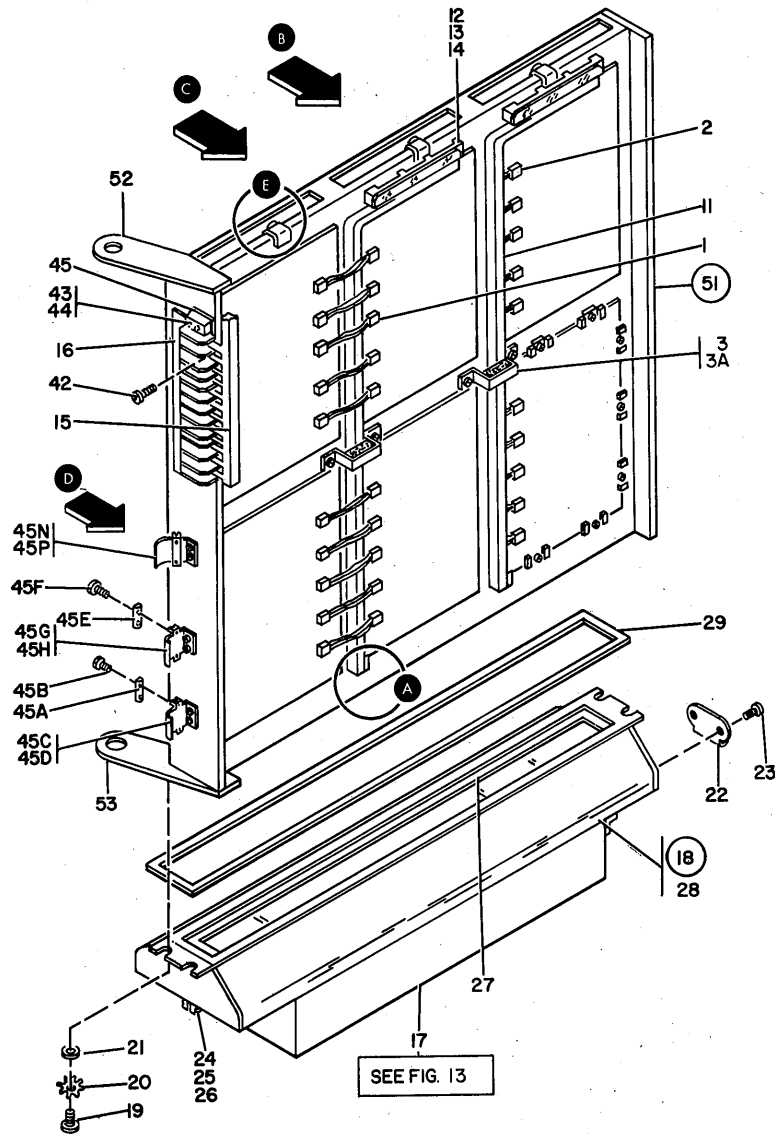

FIGURE 23. L GATE ASSEMBLY.

LIST 23. L GATE ASSEMBLY

FIGURE- INDEX NUMBER	PART NUMBER	DESCRIPTION	UNITS PER ASM.	USABLE ON CODE
23 -	5781314	L GATE ASSEMBLY	REF	
- 1	811621	FOR NEXT HIGHER ASM, SEE FIGURE 22-28 • CROSSOVER ASSEMBLY	10	
- 2	811483	FOR COMPONENT PARTS SEE FIG. 59-46 • CROSSOVER ASSEMBLY FOR COMPONENT PARTS SEE FIG. 59-50	10	
- 3	811554	• STRAP ASSEMBLY, BUS	2	
- 3A	731626	• SCREW, PAN HEAD, 6-32 X .25 LONG	4	ATT PT
- 4	438550	• SCREW, MACH-BIND HD 4-40 X 1/2 LG	2	
- 5	257985	• WASHER, FLAT-NO. 4 X 0.250 OD X 0.028 THK	2	
- 6	37913	• NUT-HEX 4-40 X .250 ID	2	
- 7	811742	• SUPPORT	2	
- 8	811426	• SCREW, MACH-PAN HD 6-32 X 3/8 IN. LG	2	ATT PT
- 9	257986	• WASHER, FLAT NO. 6	2	ATT PT
- 11	811520	• BUS ASSEMBLY, VERT., 2 BOARD	2	
- 12	811476	• TERMINAL BLOCK, BUS TO BUS	2	
- 13	811481	• SCREW, MACH- 6-32 X 1/4 LG	2	ATT PT
- 14	811536	• STANDOFF	4	
- 15	811570	• BUS ASSEMBLY	1	
- 16	5779917	• MARKER STRIP	1	
- 17	5357002	• COOLING UNIT ASSEMBLY-50/60 HZ	1	
- 18	5357035	FOR DETAIL BREAKDOWN SEE FIGURE 13 • HEADER ASSEMBLY	1	
- 19	34512	• SCREW, BIND. HD 8-32 X .375 LG	4	ATT PT
- 20	55901	• WASHER, LOCK-EXT TEETH NO. 8 X 0.381 OD	4	ATT PT
- 21	45690	• WASHER, FL - NO.10 X 7/16 OD X 1/32 THK	4	ATT PT
- 22	5349887	• STRIKE-FAN HOUSING	1	
- 23	5357136	• SCREW, PAN HD-SELF TAP 4-40 X .187 LG	2	ATT PT
- 24	472168	• CLAMP-CABLE	1	
- 25	112628	• SCREW, THREAD FORMING, BIND HD, 3/8 IN. LG	1	ATT PT
- 26	338169	• WASHER, LOCK-EXT TEETH NO. 4 X .260 OD	1	ATT PT
- 27	5313928	• SEAL, RESISTOR SHIELD	1	
- 28	5357039	• HEADER	1	
- 29	349736	• SEAL	1	
- 29A	5728861	• BRACKET-HINGE	1	
- 29B	5728860	• BRACKET-HINGE	1	
- 29C	811417	• SCREW, HEX SOCKET H- 6-32 X 1/2 LG	4	ATT PT
- 29D	5728086	• COVER-COAX CABLE	1	
- 29E	5319854	• SCREW, THD CUTTING-HEX HD 8-32 X 0.375 LG	3	ATT PT
- 29F	5353087	• BRACKET, DOUBLE ANGLE	1	
- 29G	5728866	• COVER ASSEMBLY	1	
- 29H	815963	• CATCH-PULL	4	
- 29J	815964	• SPACER-HINGE	4	
- 29K	5728864	• FOAM-BACKING	1	
- 29L	5728865	• COVER	1	
- 30	811869	• COVER ASSEMBLY-CARD	5	
- 31	815963	• CATCH-PULL	4	
- 32	815964	• SPACER-HINGE	4	
- 33	815263	• BACKING, FOAM	1	
- 34	811868	• COVER-CARD	1	
- 35	811855	• BRACKET-HINGE	5	
- 36	811854	• BRACKET-HINGE	5	
- 37	811417	• SCREW, HEX SOCKET H- 6-32 X 1/2 LG	20	ATT PT
- 38	811881	• RETAINER ASSEMBLY	11	
- 40	811442	• SEAL	11	
- 42	811481	• SCREW, MACH- 6-32 X 1/4 LG	24	
- 43	811474	• TERMINAL BLOCK ASSEMBLY	1	
- 44	811422	• SCREW, HEX H- 8-32 X 0.625 LG	4	ATT PT
- 45	811497	• INSULATOR-TERMINAL BLOCK	1	
- 45A	815220	• BAR	2	
- 45B	149898	• SCREW-CAP, HEX SOC HD 8-32 X 1 LG.	4	ATT PT
- 45C	815288	• BACKPLATE-CABLE CLAMP GANGED	2	
- 45D	813706	• SCREW, SELF TAPPING- WASH HD 10-32 X 3/8	4	ATT PT
- 45E	815220	• BAR	5	
- 45F	149898	• SCREW-CAP, HEX SOC HD 8-32 X 1 LG.	4	ATT PT
- 45G	815167	• PLATE-BACK	AR	
- 45H	813706	• SCREW, SELF TAPPING- WASH HD 10-32 X 3/8	AR	
- 45J	815220	• BAR	1	
- 45K	815173	• SCREW, CLAMP-HEX 90C HD 8-32 X 1.250 LG	2	ATT PT
- 45L	5781758	• BACKPLATE-CABLE CLAMP	1	
- 45M	813706	• SCREW, SELF TAPPING- WASH HD 10-32 X 3/8	2	ATT PT
- 45N	815171	• BACKPLATE, CABLE CLAMP	AR	
- 45P	813706	• SCREW, SELF TAPPING- WASH HD 10-32 X 3/8	AR	
- 46	2573012	• SWITCH ASM	3	
- 47	2573011	• SWITCH	1	
- 48	10170	• SCREW, MACH-BIND HD 6-32 X 1/4 LG	1	ATT PT
- 49	257969	• SETSCREW-FLUTED SOC 6-32 X 1/8 CUP PT	1	
- 50	5357073	• BRACKET-THERMAL SWITCH	1	
- 51	5781395	• GATE	1	
- 52	5722039	• HINGE-UPPER	1	
- 53	5722038	• HINGE-LOWER	1	

FOR PARTS
NOT SHOWN
SEE FIG. 22

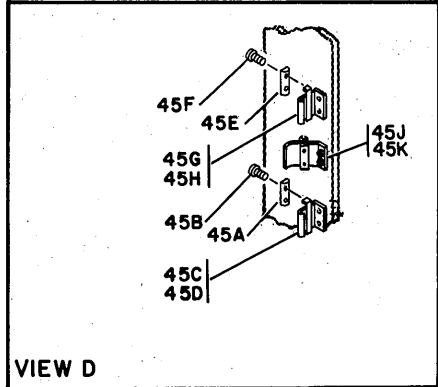
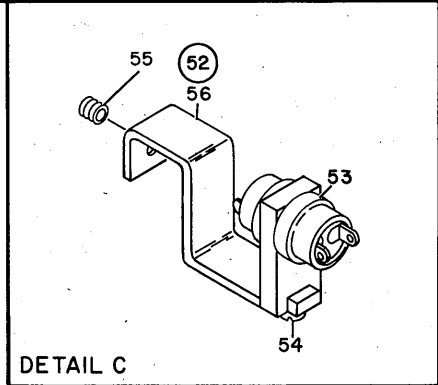
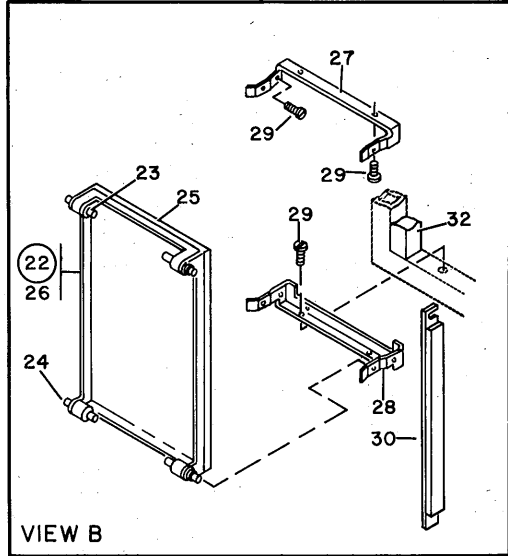
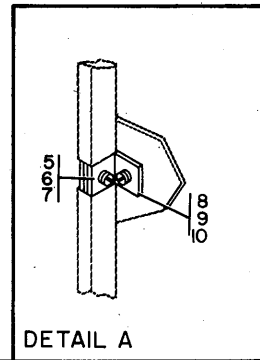
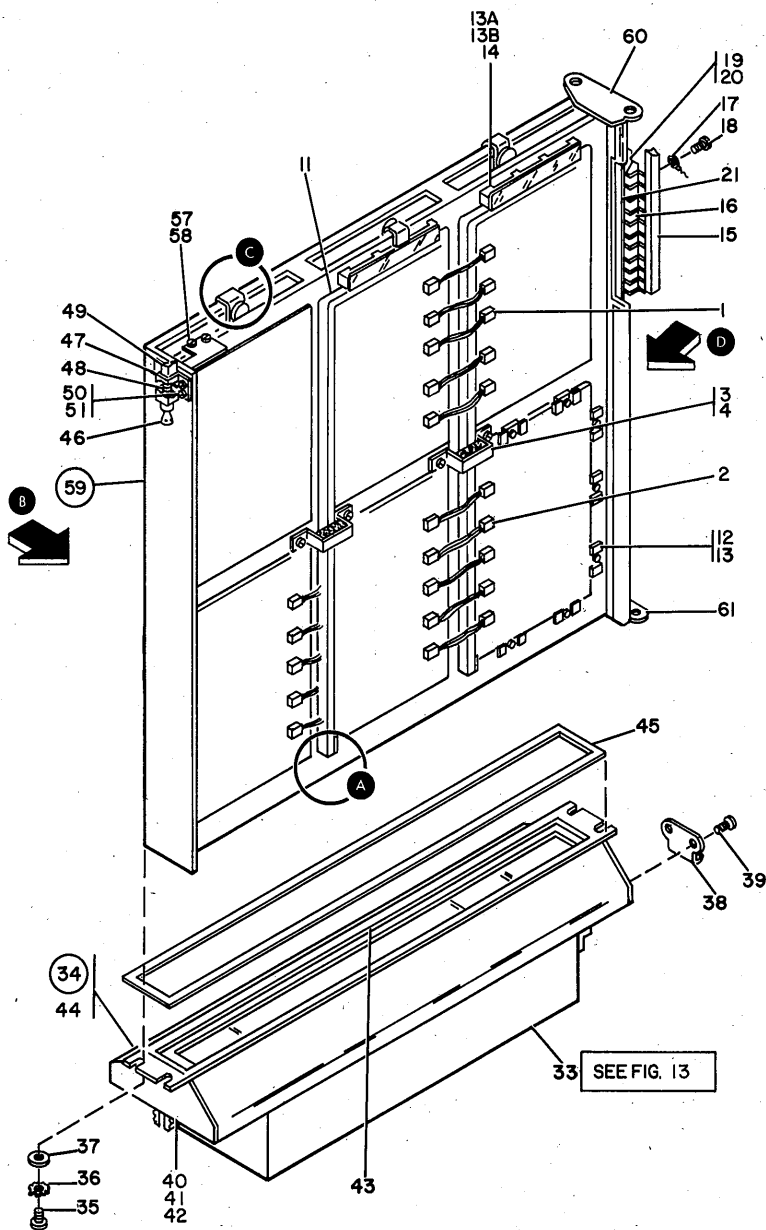

FIGURE 24. K GATE ASSEMBLY.

LIST 24. K GATE ASSEMBLY

FIGURE- INDEX NUMBER	PART NUMBER	DESCRIPTION	1 2 3 4				UNITS PER ASM.	USABLE ON CODE
			1	2	3	4		
24 -	5781315	K GATE ASSEMBLY					REF	
- 1	811483	FOR NEXT HIGHER ASM, SEE FIGURE 22-32 • CROSSOVER ASSEMBLY					1	
- 2	811621	FOR COMPONENT PARTS SEE FIG. 59-50 • CROSSOVER ASSEMBLY FOR COMPONENT PARTS SEE FIG. 59-46					10	
- 3	811554	• STRAP ASSEMBLY,BUS					2	
- 4	731626	• SCREW, PAN HEAD, 6-32 X .25 LONG				ATT PT	4	
- 5	438550	• SCREW,MACH-BIND HD 4-40 X 1/2 LG					2	
- 6	257985	• WASHER,FLAT-NO. 4 X 0.250 OD X 0.028 THK					2	
- 7	37913	• NUT-HEX 4-40 X .250 ID					2	
- 8	811742	• SUPPORT					2	
- 9	811426	• SCREW,MACH-PAN HD 6-32 X 3/8 IN. LG				ATT PT	2	
- 10	257986	• WASHER,FLAT NO. 6				ATT PT	2	
- 11	811520	• BUS ASSEMBLY, VERT., 2 BOARD					2	
- 12	813179	• CLAMP-BOARD					48	
- 13	811417	• SCREW,HEX SOCKET H- 6-32 X 1/2 LG				ATT PT	48	
- 13A	811476	• TERMINAL BLOCK,BUS TO BUS					2	
- 13B	811481	• SCREW,MACH- 6-32 X 1/4 LG				ATT PT	2	
- 14	811536	• STANDOFF					4	
- 15	811568	• BUS ASSEMBLY					1	
- 16	5779917	• MARKER STRIP					1	
- 17	811577	• JUMPER-BUS 3 POSITION					1	
- 18	811481	• SCREW,MACH- 6-32 X 1/4 LG					12	
- 19	811474	• TERMINAL BLOCK ASSEMBLY					1	
- 20	811422	• SCREW,HEX H- 8-32 X 0.625 LG				ATT PT	4	
- 21	811497	• INSULATOR-TERMINAL BLOCK					1	
- 22	811869	• COVER ASSEMBLY-CARD					5	
- 23	815963	• CATCH-PULL					4	
- 24	815964	• SPACER-HINGE					4	
- 25	815263	• BACKING, FOAM					1	
- 26	811868	• COVER-CARD					1	
- 27	811855	• BRACKET-HINGE					6	
- 28	811854	• BRACKET-HINGE					6	
- 29	811417	• SCREW,HEX SOCKET H- 6-32 X 1/2 LG				ATT PT	24	
- 30	811881	• RETAINER ASSEMBLY					12	
- 32	811442	• SEAL					12	
- 33	5357002	• COOLING UNIT ASSEMBLY-50/60 HZ FOR DETAIL BREAKDOWN SEE FIGURE 13					1	
- 34	5357035	• HEADER ASSEMBLY					1	
- 35	34512	• SCREW,BIND,HD 8-32 X .375 LG				ATT PT	4	
- 36	55901	• WASHER,LOCK-EXT TEETH NO. 8 X 0.381 OD				ATT PT	4	
- 37	45690	• WASHER, FL - NO.10 X 7/16 OD X 1/32 THK				ATT PT	4	
- 38	5349887	• STRIKE-FAN HOUSING					1	
- 39	5357136	• SCREW,PAN HD-SELF TAP 4-40 X .187 LG				ATT PT	2	
- 40	472168	• CLAMP-CABLE					1	
- 41	112628	• SCREW,THREAD FORMING,BIND HD,3/8 IN. LG				ATT PT	1	
- 42	338169	• WASHER,LOCK-EXT TEETH NO. 4 X .260 OD				ATT PT	1	
- 43	5313928	• SEAL,RESISTOR SHIELD					1	
- 44	5357039	• HEADER					1	
- 45	349736	• SEAL					1	
- 45A	815220	• BAR					2	
- 45B	149898	• SCREW-CAP,HEX SOC HD 8-32 X 1 LG.				ATT PT	4	
- 45C	815288	• BACKPLATE-CABLE CLAMP GANGED					2	
- 45D	813706	• SCREW,SELF TAPPING- WASH HD 10-32 X 3/8				ATT PT	4	
- 45E	815220	• BAR					2	
- 45F	149898	• SCREW-CAP,HEX SOC HD 8-32 X 1 LG.				ATT PT	4	
- 45G	815167	• PLATE-BACK					AR	
- 45H	813706	• SCREW,SELF TAPPING- WASH HD 10-32 X 3/8				ATT PT	AR	
- 45J	815171	• BACKPLATE, CABLE CLAMP					AR	
- 45K	813706	• SCREW,SELF TAPPING- WASH HD 10-32 X 3/8				ATT PT	AR	
- 46	5722052	• PIN-LATCH					1	
- 47	517928	• PIN,SPRING- 0.125 X 7/8 LG					1	
- 48	236569	• SPRING-COMPRESSION					1	
- 49	5722051	• LATCH-GATE					1	
- 50	5722050	• BRACKET-LATCH SUPPORT					1	
- 51	734483	• SCREW,PAN HD- 6-32 X 0.380 LG				ATT PT	4	
- 52	2573012	• SWITCH ASM					3	
- 53	2573011	• SWITCH					1	
- 54	10170	• SCREW,MACH-BIND HD 6-32 X 1/4 LG				ATT PT	1	
- 55	257969	• SETSCREW-FLUTED SOC 6-32 X 1/8 CUP PT					1	
- 56	5357073	• BRACKET-THERMAL SWITCH					1	
- 57	5722056	• BLOCK-GATE STOP					1	
- 58	5319854	• SCREW,THD CUTTING-HEX HD 8-32 X 0.375 LG				ATT PT	2	
- 59	5781365	• GATE					1	
- 60	5722028	• HINGE-UPPER					1	
- 61	5781364	• HINGE-LOWER					1	

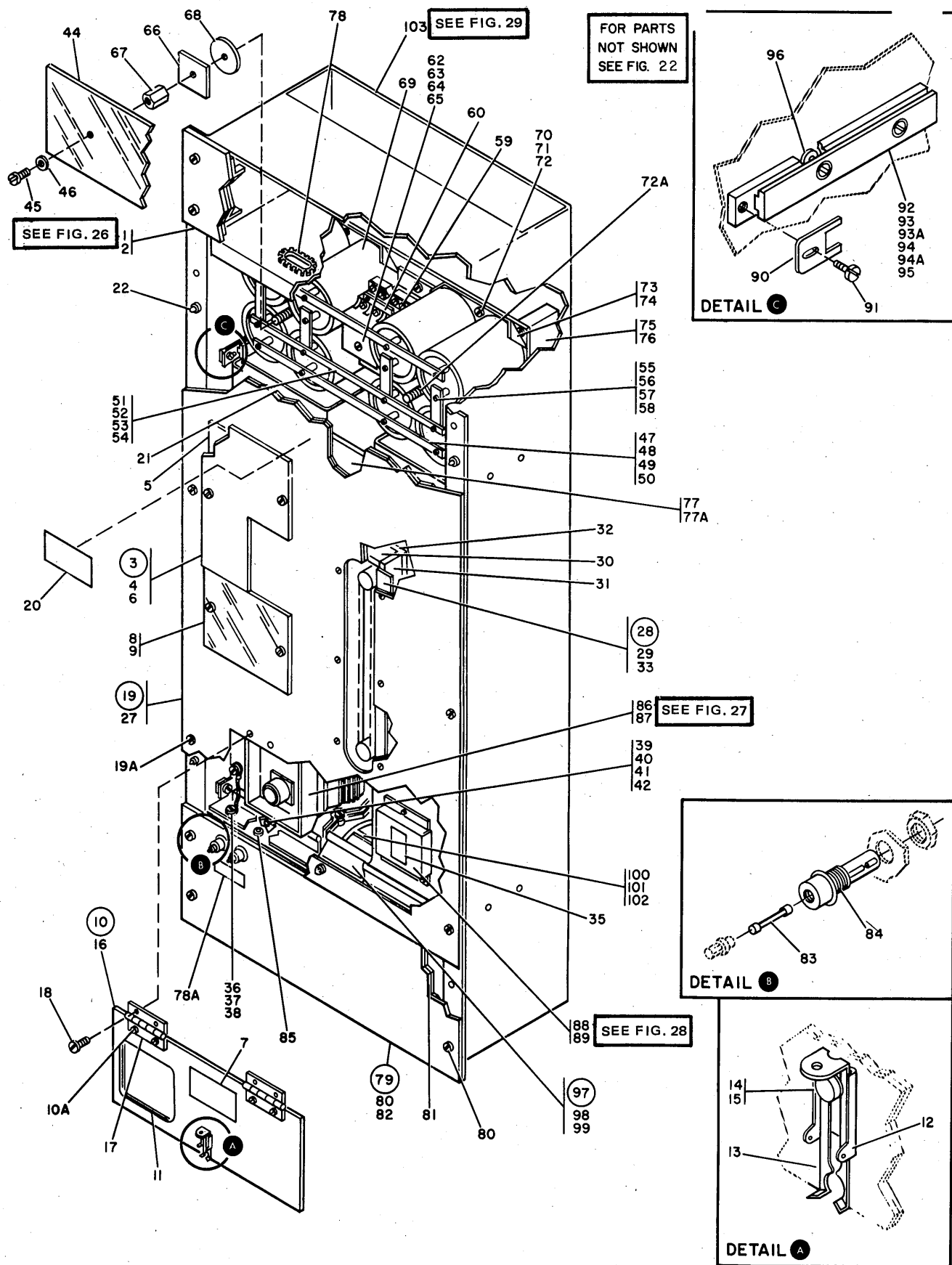

FIGURE 25. 75 AMP CONVERTER INVERTER ASSEMBLY.

LIST 25. 75 AMP CONVERTER INVERTER ASSEMBLY

FIGURE- INDEX NUMBER	PART NUMBER	DESCRIPTION	UNITS PER ASM.	USABLE ON CODE
25 -	5703200	75 AMP CONVERTER INVERTER ASM FOR NEXT HIGHER ASM, SEE FIGURE 22-83	REF	
- 1	5712039	. RESISTOR ASSEMBLY-UPPER COVER FOR DETAIL BREAKDOWN SEE FIGURE 26	1	
- 2	58207	. SCREW, MACH-UNDRCT BIND HD 8-32 X 1/4 LG	4	ATT PT
- 3	5261372	. CARD COVER ASM	1	
- 4	438548	. SCREW, MACH-BIND HD 4-40 X 3/16 LG	2	ATT PT
- 5	5261576	. INSULATOR-COVER	1	
- 6	5703246	. COVER	1	
- 7	5709006	. PLATE, INSTRUCTION	1	
- 8	5761493	. COVER-INDICATOR	1	
- 9	251970	. SCREW-MACH BD. HD. 4-40 X 1/4 LG	2	ATT PT
- 10	5261381	. COVER ASM-HINGED	1	
- 10A	55726	. SCREW, MACH-BIND HD 6-32 X .188 LG	4	ATT PT
- 11	5261577	. INSULATOR, COVER	1	
- 12	5261595	. GUIDE	1	
- 13	5261594	. LATCH	1	
- 14	5261591	. RIVET, SOLID	1	ATT PT
- 15	5261383	. WASHER, CUPPED- 15764 ID X 7/16 OD	1	ATT PT
- 16	5703243	. COVER, HINGED	1	
- 17	5703242	. HINGE	2	
- 18	55726	. SCREW, MACH-BIND HD 6-32 X .188 LG	4	ATT PT
- 19	2611709	. COVER ASM	1	
- 19A	236849	. SCREW, MACH-BIND HD 10-32 X 0.250 LG	6	ATT PT
- 20	5261629	. LABEL-MAIN COVER	1	
- 21	5261353	. INSULATOR, COVER	1	
- 22	5261592	. STUD, SPRING CLIP- 1/4 X 3/8 OD X 1/2 LG	1	
- 27	2611708	. COVER	1	
- 28	5261382	. SHIELD ASM	1	
- 29	55726	. SCREW, MACH-BIND HD 6-32 X .188 LG	6	ATT PT
- 30	5261574	. INSULATOR	2	
- 31	5261573	. INSULATOR	2	
- 32	5261572	. INSULATOR	1	
- 33	5261569	. COVER-OUTPUT	1	
- 35	5261598	. PLATE, INSTRUCTION-FUSES	1	
- 36	528484	. JUMPER ASSEMBLY-GROUND	AR	
- 37	236849	FOR COMPONENT PARTS SEE FIGURES 59-35 . SCREW, MACH-BIND HD 10-32 X 0.250 LG	4	ATT PT
- 38	56079	. WASHER, LOCK-EXT T .195 ID .410 OD	4	ATT PT
- 39	216362	. CLAMP-CABLE	1	
- 40	186758	. SCREW, MACH-BIND HD 8-32 X 0.438	1	ATT PT
- 41	1090873	. WASHER, LOCK, SPLIT RING- .168 ID, .296 OD	1	ATT PT
- 42	22478	. WASHER, FL- 0.170 ID 0.375 OD 0.32 THK	1	ATT PT
- 44	5703253	. SHIELD, SAFETY-CAPACITOR	1	
- 45	322029	. SCREW, MACH-BIND HD 1/4-20 X 1/2 LG	2	ATT PT
- 46	3550	. WASHER, FL- 1/4 X 9/16 OD X 0.050 THK	2	ATT PT
- 47	5703256	. BUS BAR-CAPACITOR	2	
- 48	32042	. SCREW, MACH BIND. HD 10-32 X 3/8 LG.	AR	ATT PT
- 49	9092	. WASHER-LOCK, SPLIT RING, .194 ID .337OD	8	ATT PT
- 50	45690	. WASHER, FL - NO.10 X 7/16 OD X 1/32 THK	8	ATT PT
- 51	5703256	. BUS BAR-CAPACITOR	1	
- 52	32617	. SCREW, MACH-BIND HD 10-32 X 0.438 LG	4	ATT PT
- 53	9092	. WASHER-LOCK, SPLIT RING, .194 ID .337OD	4	ATT PT
- 54	45690	. WASHER, FL - NO.10 X 7/16 OD X 1/32 THK	4	ATT PT
- 55	5703255	. BUS BAR-CAPACITOR	4	
- 56	32042	. SCREW, MACH BIND. HD 10-32 X 3/8 LG.	4	ATT PT
- 57	9092	. WASHER-LOCK, SPLIT RING, .194 ID .337OD	4	ATT PT
- 58	45690	. WASHER, FL - NO.10 X 7/16 OD X 1/32 THK	4	ATT PT
- 59	236849	. SCREW, MACH-BIND HD 10-32 X 0.250 LG	2	
- 60	5708938	. BUS CONNECTOR	2	
- 62	5276703	. RELAY-24 VDC COIL	1	
- 63	28413	. SCREW, MACH-BIND HD 10-32 X 5/16 LG	2	ATT PT
- 64	56079	. WASHER, LOCK-EXT T .195 ID .410 OD	2	ATT PT
- 65	45690	. WASHER, FL - NO.10 X 7/16 OD X 1/32 THK	2	ATT PT
- 66	5703249	. CLAMP-CAPACITOR	2	
- 67	222027	. SPACER-HEX 1/4-20 THD THRU HOLE 1 LG OA	2	ATT PT
- 68	5703248	. CLAMP-CAPACITOR	2	
- 69	5261442	. CAPACITOR, FIXED, ELECT- 3200 UF 200V	8	
- 70	5703247	. BASE	2	
- 71	236849	. SCREW, MACH-BIND HD 10-32 X 0.250 LG	8	ATT PT
- 72	56079	. WASHER, LOCK-EXT T .195 ID .410 OD	8	ATT PT
- 72A	363447	. BOLT, SQUARE NECK 1/4-20 X 4-3/4 LG	2	
- 73	5712023	. PLATE, MOUNTING-CAPACITOR	1	
- 74	325660	. SCREW-MACH FH 1/4-20 X .625 LG	4	ATT PT

LIST 25. 75 AMP CONVERTER INVERTER ASSEMBLY

FIGURE- INDEX NUMBER	PART NUMBER	DESCRIPTION	UNITS PER ASM.	USABLE ON CODE
25 -	75	5712025		
- 76	25895	. PLATE, SUPPORT	2	
- 77	2572736	. SCREW, MACH-FH 1/4-20 X 3/4 LG	4	ATT PT
- 77A	58207	. BAFFLE ASM, AIR	1	
- 78	730432	. SCREW, MACH-UNDRCT BIND HD 8-32 X 1/4 LG	3	ATT PT
- 78A	5709059	. GROMMET, CATERPILLAR	AR	
- 79	5261597	. NAMEPLATE, FAN FUSES	1	
- 80	58207	. COVER ASM-BOTTOM	1	
- 81	5261330	. SCREW, MACH-UNDRCT BIND HD 8-32 X 1/4 LG	4	ATT PT
- 82	5703262	. GROMMET, CATERPILLAR	1	
- 83	78999	. INSULATOR-COVER BOTTOM	1	
- 84	360882	. COVER-BOTTOM	1	
- 85	53193	. FUSE, CARTRIDGE-LG TIME LAG 0.5AMP	2	
- 86	5703223	. FUSEHOLDER- 15 AMP 250V AC	2	
- 87	473536	. GROMMET, RUB-FOR 7/16 HOLE X 3/32 PNL	1	
- 88	2572735	. 75 AMP CONVERTER ASSEMBLY- 60 HZ FOR DETAIL BREAKDOWN SEE FIGURE 27	1	
- 89	473536	. SEAL	AR	
- 90	5235193	. 75 AMP INVERTER SECTION ASSEMBLY FOR DETAIL BREAKDOWN SEE FIGURE 28	1	
- 91	186759	. SEAL	AR	
- 92	5261608	. KEEPER-POWER SUPPLY	4	
- 93	5762573	. SCREW, MACH-BIND HD 8-32 X 5/16 LG	4	ATT PT
- 93A	45690	. RAIL, MTG	4	
- 94	9092	. SCREW-SOCKET CAP	8	ATT PT
- 94A	56079	. WASHER, FL - NO.10 X 7/16 OD X 1/32 THK	8	ATT PT
- 95	125930	. WASHER-LOCK, SPLIT RING, .194 ID .337OD	8	ATT PT
- 96	353526	. WASHER, LOCK-EXT T .195 ID .410 OD	8	ATT PT
- 97	5712034	. NUT-STOP, ELASTIC HEX 10-32	8	ATT PT
- 98	223528	. SPACER-LOWER TRIM	8	
- 99	5712024	. BAFFLE, AIR	1	
- 100	5700650	. CHANNEL, RUBBER-COVER	AR	
- 101	32617	. AIR BAFFLE	1	
- 102	56121	. FAN-FEATHER TYPE 203-60 CY	1	
- 103	2611714	. SCREW, MACH-BIND HD 10-32 X 0.438 LG	2	ATT PT
		. WASHER, LOCK-INT TEETH NO. 10 X 0.381 OD	2	ATT PT
		. TUB AND LINER ASSEMBLY FOR DETAIL BREAKDOWN SEE FIGURE 29.	1	

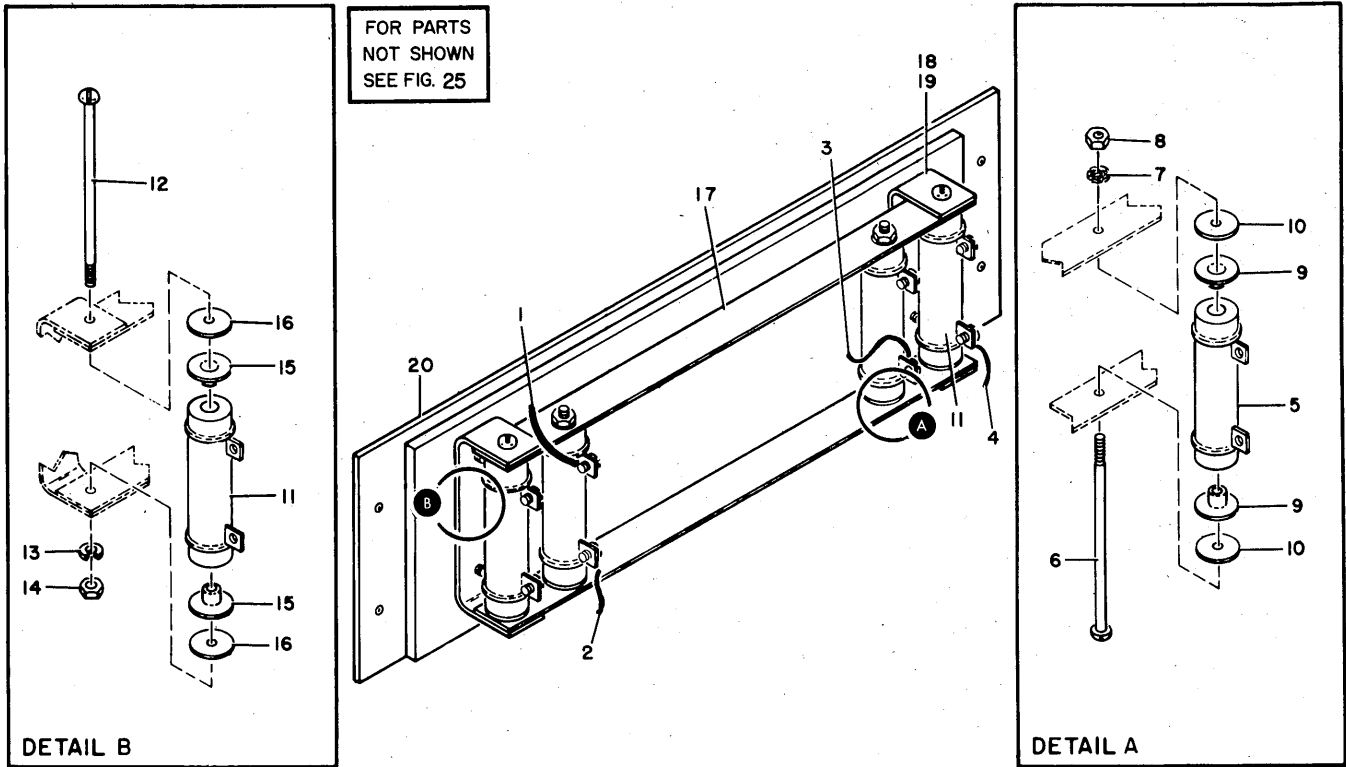

FIGURE 26. UPPER COVER RESISTOR ASSEMBLY.

LIST 26. UPPER COVER RESISTOR ASSEMBLY

FIGURE- INDEX NUMBER	PART NUMBER	DESCRIPTION				UNITS PER ASM.	USABLE ON CODE
		1	2	3	4		
26 -	5712039	RESISTOR ASSEMBLY-UPPER COVER				REF	
- 1	5758602	FOR NEXT HIGHER ASM, SEE FIGURE 25-1 • JUMPER ASM-#8				2	
- 2	5758615	FOR COMPONENT PARTS SEE FIG. 59-40 • JUMPER ASM-#8				1	
- 3	5758616	FOR COMPONENT PARTS SEE FIG. 59-40,-41 • JUMPER ASM-#8				1	
- 4	5758610	FOR COMPONENT PARTS SEE FIG. 59-40 • JUMPER ASM-#8				1	
- 5	5261435	• RESISTOR,FXD,WW- 0.05 OHMS P/M 15% 155W				2	
- 6	223410	• SCREW,MACH-RH 10-32 X 4-3/4 LG ATT PT				2	
- 7	56079	• WASHER,LOCK-EXT 1.195 ID .410 OD ATT PT				2	
- 8	11598	• NUT,PLAIN-HEX 10-32 X 3/8 FL W ATT PT				2	
- 9	515380	• WASHER-CENTERING				4	
- 10	515381	• WASHER,MICA				4	
- 11	5261435	• RESISTOR,FXD,WW- 0.05 OHMS P/M 15% 155W				2	
- 12	515718	• SCREW-FIL HD, NO. 8-32 X 5 IN LG ATT PT				2	
- 13	1090873	• WASHER,LOCK,SPLIT RING- .168 ID, .296 OD ATT PT				2	
- 14	257189	• NUT,HEX- 8-32 ATT PT				2	
- 15	515380	• WASHER-CENTERING				4	
- 16	515381	• WASHER,MICA				4	
- 17	5712028	• BAR,RESISTOR MOUNTING				2	
- 18	5712027	• BRACKET,RESISTOR				2	
- 19	32042	• SCREW, MACH BIND. HD 10-32 X 3/8 LG. ATT PT				2	
- 20	5261599	• COVER ASM-TOP				1	

FOR PARTS
NOT SHOWN
SEE FIG. 25

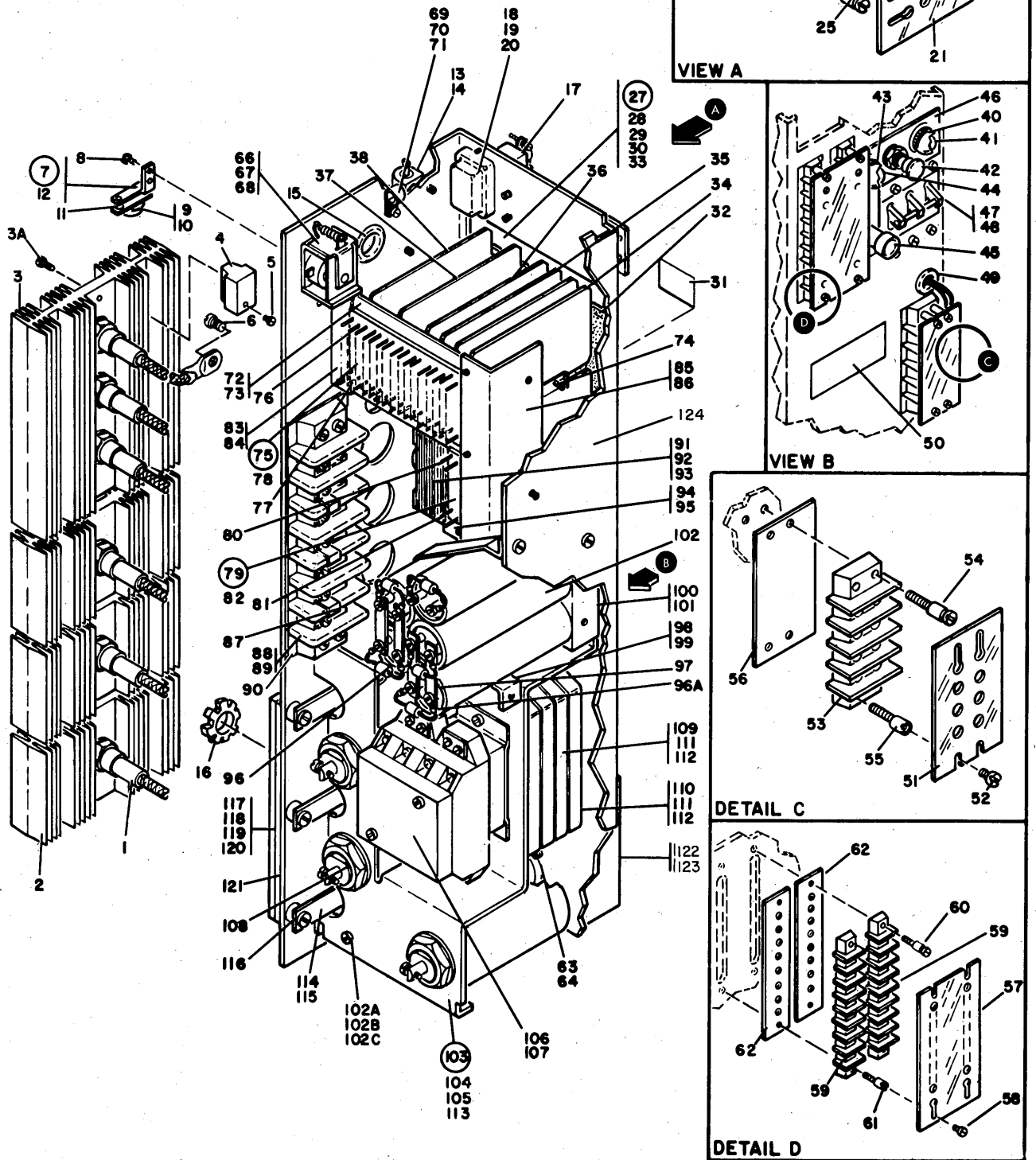

FIGURE 27. 75 AMP CONVERTER ASSEMBLY.

LIST 27. 75 AMP CONVERTER ASSEMBLY

FIGURE- INDEX NUMBER	PART NUMBER	DESCRIPTION	UNITS PER ASM.	USABLE ON CODE
27 -	5703223	75 AMP CONVERTER ASSEMBLY- 60 HZ FOR NEXT HIGHER ASM, SEE FIGURE 25-86	REF	
- 1	5261456	. RECTIFIER, SILICON	6	
- 2	5703239	. HEATSINK-DIODE MTG	3	
- 3	5703238	. HEATSINK-DIODE MTG	1	
- 3A	79779	. SCREW, THD CTG-BIND HD NO. 6 X 3/4 LG	10	ATT PT
- 4	473531	. INSULATOR	10	
- 5	473544	. SCREW, BINDING HEAD SELF TAP NO 6 1/2 IN	9	ATT PT
- 6	32042	. SCREW, MACH BIND. HD 10-32 X 3/8 LG.	4	
- 7	5762133	. SWITCH ASM	1	
- 8	251970	. SCREW-MACH BD. HD. 4-40 X 1/4 LG	2	ATT PT
- 9	5257518	. THERMOSWITCH	1	
- 10	507234	. SCREW, MACH-BIND HD 4-40 X 3/8 LG	2	ATT PT
- 11	483111	. SPACER	2	
- 12	5762119	. BRACKET-THERMAL SWITCH	1	
- 13	5261438	. RESISTOR, FIXED-WW 750 OHMS P/M 3% 50W	2	
- 14	338238	. SCREW, MACH-BD HD 4-40 NC X .3125 LG	4	ATT PT
- 15	313997	. GROMMET, RUB-FOR 7/8 HOLE X 1/16 PNL	1	
- 16	730432	. GROMMET, CATERPILLAR	1	
- 17	204464	. CONNECTOR, PLUG, ELEC- 4 MALE CONTACTS	1	
- 18	5213765	. CONNECTOR, RECP, ELEC-4 FEMAL CONTACTS	1	
- 19	251970	. SCREW-MACH BD. HD. 4-40 X 1/4 LG	AR	ATT PT
- 20	150209	. WASHER, LOCK-INT TEETH NO. 4 X 17/64 OD	AR	ATT PT
- 21	5703264	. SHIELD, SAFETY	1	
- 22	210984	. SCREW, RD HD MACH-6-32 X .250 LG	1	ATT PT
- 23	5703258	. STUD-TAPPED	1	
- 24	5261460	. TERMINAL BOARD-3 POS	1	
- 25	5703257	. STUD-SHIELD MTG	3	ATT PT
- 26	5703260	. MARKER STRIP-3 POS	1	
- 27	5712046	. RETAINER ASM-CARDS, 75 AMP C/I	1	
- 28	332620	. SCREW, MACH-BIND HD 10-32 X 1/2 LG	2	ATT PT
- 29	45690	. WASHER, FL - NO.10 X 7/16 OD X 1/32 THK	2	ATT PT
- 30	9092	. WASHER-LOCK, SPLIT RING, .194 ID .337OD	2	ATT PT
- 31	5261304	. LABEL	1	
- 32	349736	. SEAL	1	
- 33	5712044	. PLATE, CARD RETAINER	1	
- 34	374223	. CARD ASM	1	
- 35	374982	. CARD ASM	2	
- 36	374785	. CARD ASM	1	
- 37	374788	. CARD ASM	1	
- 38	375316	. CARD ASSEMBLY	1	
- 40	5261463	. LAMP HOLDER-AMBER LENS	1	
- 41	5212657	. LAMP	1	
- 42	220918	. CIRCUIT BREAKER- 1 POLE 30V DC 5 AMP	1	
- 43	5261465	. LAMP HOLDER-GREEN LENS	1	
- 44	2414970	. LAMP, INCANDESCENT	1	
- 45	5261449	. SWITCH, PUSHBUTTON-SPST	1	
- 46	5703241	. NAMEPLATE	1	
- 47	5213479	. CIRCUIT BREAKER, 3 POLE SPD	1	
- 48	10170	. SCREW, MACH-BIND HD 6-32 X 1/4 LG	6	ATT PT
- 49	317138	. GROMMET, RUB-FOR 7/16 HOLE X 1/8 PNL	1	
- 50	5261702	. LABEL, CONVERTER-60 CY	1	
- 51	187858	. SHIELD, TERMINAL BLOCK- 30 AMP 4 POS	1	
- 52	210984	. SCREW, RD HD MACH-6-32 X .250 LG	1	ATT PT
- 53	91469	. TERMINAL BOARD- 4 DBL SCREW TERMINALS	1	
- 54	210986	. STUD-SHIELD MOUNTING	3	ATT PT
- 55	210985	. STUD, EXT-INT 6-32 EXT 8-32 X 0.900 LG OA	1	ATT PT
- 56	589759	. STRIP-MARKER	1	
- 57	5703244	. SHIELD-TERMINAL BOARD	1	
- 58	210984	. SCREW, RD HD MACH-6-32 X .250 LG	1	ATT PT
- 59	5261450	. TERMINAL BOARD-8 POS	2	
- 60	210884	. STUD-SHIELD MTG, NO. 6-32	3	ATT PT
- 61	210883	. STUD-SHIELD MTG, TAPPED, NO. 6-32	1	ATT PT
- 62	5261416	. MARKER STRIP-8 POS	2	
- 63	5261453	. CONNECTOR, RECP, ELEC-7 MALE CONTACTS	1	
- 64	38235	. SCREW, MACH-BIND HD 6-32 X 0.312 LG	4	ATT PT
- 66	2128689	. RELAY, 3 POLE DT 472 OHM 24 VOLT D.C. COIL	1	
- 67	257187	. NUT, PLAIN, HEX- 6-32 X 3/8 FL W	1	ATT PT
- 68	6364	. WASHER, LOCK-SPLIT NO. 6 X 1/4 OD	1	ATT PT
- 69	357433	. CLAMP, LOOP- 0.187 ID 0.203 DIA MTG HOLE	1	
- 70	10170	. SCREW, MACH-BIND HD 6-32 X 1/4 LG	1	ATT PT
- 71	6364	. WASHER, LOCK-SPLIT NO. 6 X 1/4 OD	1	ATT PT
- 72	5703236	. T-BAR, CARD BLOCK MTG	2	
- 73	55726	. SCREW, MACH-BIND HD 6-32 X .188 LG	4	ATT PT

LIST 27. 75 AMP CONVERTER ASSEMBLY

FIGURE- INDEX NUMBER	PART NUMBER	DESCRIPTION	UNITS PER ASM.	USABLE ON CODE
27 - 74	216085	. GUIDE-CARD 8 POSITION LONG	1	
- 75	216083	. CARD RECEPTACLE ASSEMBLY	1	
- 76	216087	. . . SPRING-CONTACT	64	
- 77	216088	. . . SPRING-CONTACT	64	
- 78	216082	. . . CARD RECEPTACLE- 8 POSITION	1	
- 79	216076	. TERMINAL BLOCK AND CONTACT ASSEMBLY	1	
- 80	216087	. . . SPRING-CONTACT	8	
- 81	216088	. . . SPRING-CONTACT	7	
- 82	216073	. . . TERMINAL BLOCK AND CONTACT ASSEMBLY	1	
- 83	5703228	. BRACKET-CARD BLOCK MTG	1	
- 84	236849	. SCREW, MACH-BIND HD 10-32 X 0.250 LG	2	ATT PT
- 85	5703237	. BRACKET-CARD BLOCK MOUNTING	1	
- 86	236849	. SCREW, MACH-BIND HD 10-32 X 0.250 LG	2	ATT PT
- 87	5261434	. JUMPER-TERM STRIP	3	
- 88	5261461	. TERMINAL BOARD-7 POS	1	
- 89	5528	. SCREW, MACH BIND HD 8-32 X .625 LG	AR	ATT PT
- 90	5261426	. MARKER STRIP-7 POS	1	
- 91	5261443	. TRANSFORMER-POWER STEP DOWN	1	
- 92	236849	. SCREW, MACH-BIND HD 10-32 X 0.250 LG	4	ATT PT
- 93	56079	. WASHER, LOCK-EXT T .195 ID .410 OD	4	ATT PT
- 94	5703250	. RETAINER	1	ATT PT
- 95	55726	. SCREW, MACH-BIND HD 6-32 X .188 LG	1	ATT PT
- 96	5261355	. RESISTOR ASM-3.9K P/M 5% 1/2 W	5	
- 96	317022	. RESISTOR, FIXED COMP 3.9K, 5%, 1/2 WATT	5	
- 96A	334932	. TERMINAL-RING, 18-22 AWG, #10 HOLE, INS	10	
- 97	5261596	. BUS BAR-AC CAPACITOR	4	
- 98	5703233	. RETAINING STRAP-CAPACITOR	1	
- 99	38235	. SCREW, MACH-BIND HD 6-32 X 0.312 LG	2	ATT PT
- 100	5703231	. BRACKET-CAPACITOR MTG	1	
- 101	28413	. SCREW, MACH-BIND HD 10-32 X 5/16 LG	2	ATT PT
- 102	208237	. CAPACITOR, FXD, ELEC-4000UF P150 M10 30VDC	5	
- 102A	32042	. SCREW, MACH BIND. HD 10-32 X 3/8 LG.	1	
- 102B	56079	. WASHER, LOCK-EXT T .195 ID .410 OD	1	
- 102C	11598	. NUT, PLAIN-HEX 10-32 X 3/8 FL W	1	
- 103	5261452	. COMPONENT MTG ASM	1	
- 104	186759	. SCREW, MACH-BIND HD 8-32 X 5/16 LG	2	ATT PT
- 105	28413	. SCREW, MACH-BIND HD 10-32 X 5/16 LG	2	ATT PT
- 106	5261448	. RELAY-24 VDC COIL	1	
- 107	236849	. SCREW, MACH-BIND HD 10-32 X 0.250 LG	2	ATT PT
- 108	5261446	. . . FILTER-RFI	3	
- 109	5261436	. RESISTOR, FIXED-WW 5 OHMS P/M 10% 150W	3	
- 110	5261437	. RESISTOR, FIXED-WW 750 OHMS P/M 10% 150W	1	
- 111	438605	. SCREW, MACH-UNDRCT BIND HD 10-32 X 3/4 LG	2	ATT PT
- 112	45690	. WASHER, FL - NO.10 X 7/16 OD X 1/32 THK	2	ATT PT
- 113	5703226	. BRACKET-FILTER, CONN, RES MTG	1	
- 114	5703230	. TAB-BUS BAR	3	
- 115	32042	. SCREW, MACH BIND. HD 10-32 X 3/8 LG.	3	ATT PT
- 116	5703229	. BUSHING-INSULATING	3	
- 117	5703234	. BUS BAR	1	
- 118	507796	. SCREW, MACH-BIND HD 10-32 X 1 LG	1	ATT PT
- 119	9092	. WASHER-LOCK, SPLIT RING, .194 ID .337OD	3	ATT PT
- 120	11598	. NUT, PLAIN-HEX 10-32 X 3/8 FL W	3	ATT PT
- 121	5703235	. INSULATOR-BUS BAR	1	
- 122	5261570	. COVER-INPUT CONN	1	
- 123	438548	. SCREW, MACH-BIND HD 4-40 X 3/16 LG	4	ATT PT
- 124	5703224	. CHASSIS-AC SECT 75 AMP CONVERT-INVERT	1	

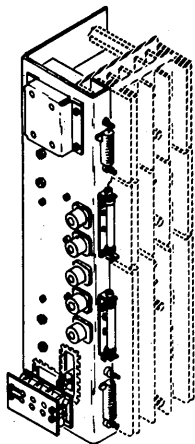

FOR PARTS
NOT SHOWN
SEE FIG. 25

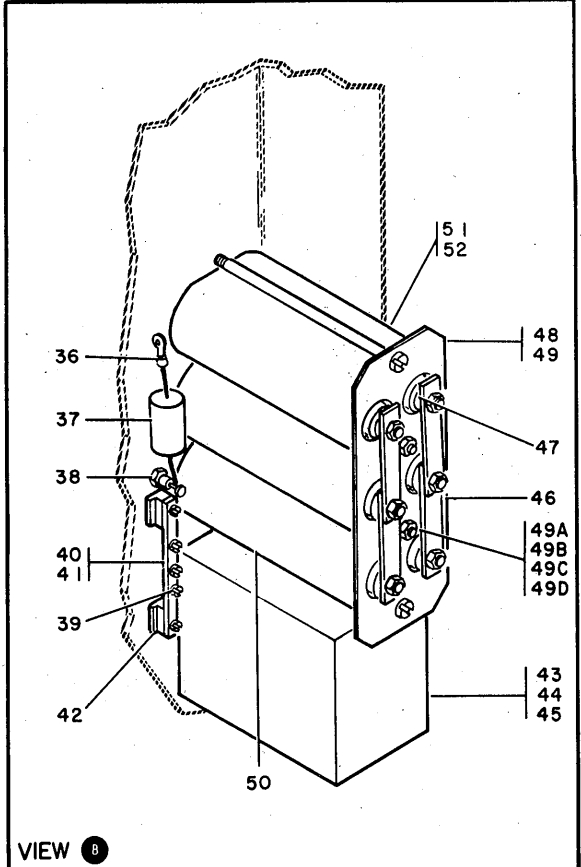
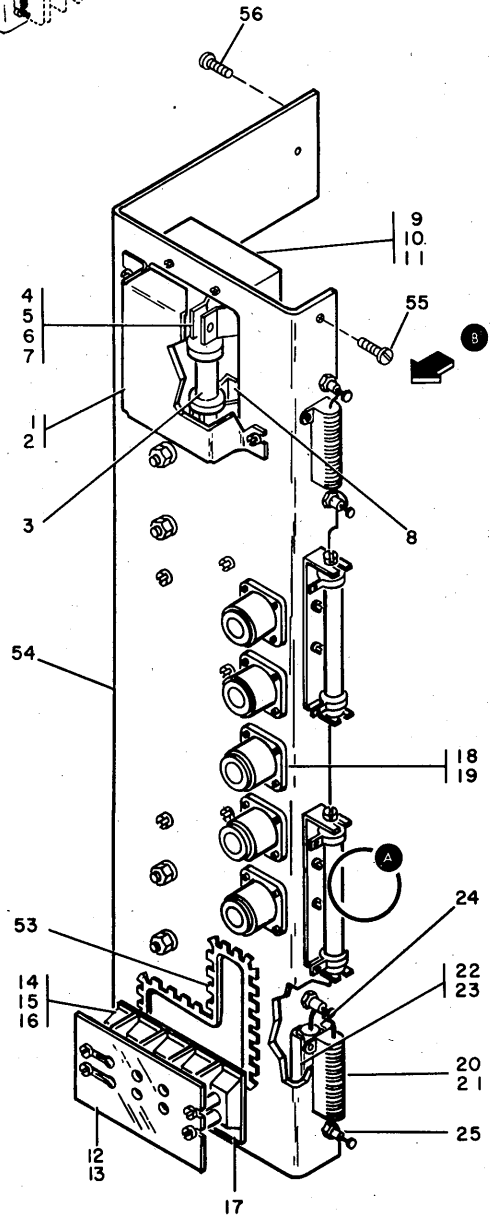
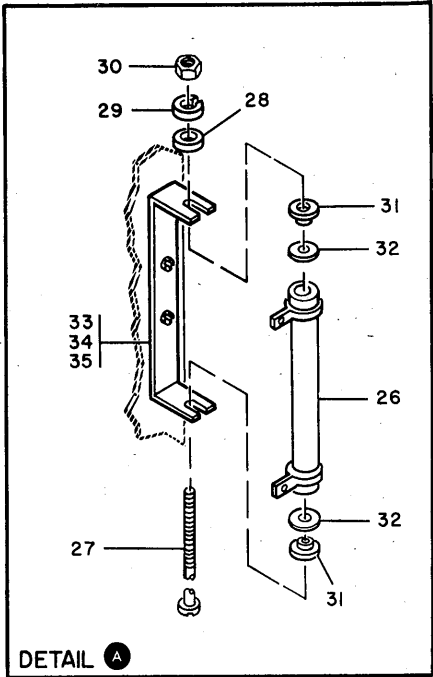

FIGURE 28. 75 AMP INVERTER SECTION ASSEMBLY. (SHEET 1 OF 2. INDEX NOS. 1-56)

LIST 28. 75 AMP INVERTER SECTION ASSEMBLY

FIGURE- INDEX NUMBER	PART NUMBER	DESCRIPTION	UNITS	USABLE ON CODE
			PER ASM.	
28 -	2572735	75 AMP INVERTER SECTION ASSEMBLY FOR NEXT HIGHER ASM, SEE FIGURE 25-88	REF	
- 1	5703215	. SHIELD-FUSE	1	
- 2	10170	. SCREW,MACH-BIND HD 6-32 X 1/4 LG	4	
- 3	5261451	. FUSE,CARTRIDGE-50 AMP 250V	2	
- 4	5703220	. CONTACT	4	
- 5	5703213	. STUD-FUSE BLOCK MTG	4	
- 6	6935	. WASHER,LOCK-SPLIT 1/4 X 0.493 OD	4	
- 7	36109	. NUT,PLAIN,HEX- 1/4-20 X 7/16 FL W	4	
- 8	5703214	. PLATE,LOCKING-FUSE	4	
- 9	5703212	. BLOCK-FUSE MTG	1	
- 10	332620	. SCREW,MACH-BIND HD 10-32 X 1/2 LG	4	
- 11	56079	. WASHER,LOCK-EXT I .195 ID .410 OD	4	
- 12	5703264	. SHIELD,SAFETY	1	
- 13	210984	. SCREW, RD HD MACH-6-32 X .250 LG	1	
- 14	5261460	. TERMINAL BOARD-3 POS	1	
- 15	5703257	. STUD-SHIELD MTG	3	
- 16	5703258	. STUD-TAPPED	1	
- 17	5703260	. MARKER STRIP-3 POS	1	
- 18	368353	. RECEPTACLE	5	
- 19	338238	. SCREW, MACH-BD HD 4-40 NC X .3125 LG	20	
- 20	5240462	. RESISTOR,FXD,WW-150 OHMS P/M 5% 50W	2	
- 21	438548	. SCREW,MACH-BIND HD 4-40 X 3/16 LG	4	
- 22	5703207	. CLIP, COMPONENT	2	
- 23	48594	. SCREW,MACH-BIND HD 6-32 X 0.250 LG	4	
- 24	5213874	. CAPACITOR,FXD,PAPER DIELECTRIC,0.1UF	2	
- 25	5261458	. TERMINAL-INSULATED FEED THRU	4	
- 26	5261439	. RESISTOR,FIXED-WW 30 OHMS P/M 5% 35W	2	
- 27	331982	. SCREW,MACH RD HD 8-32 X 1-1/4 LG	2	
- 28	22478	. WASHER,FL- 0.170 ID 0.375 OD 0.32 THK	2	
- 29	1090873	. WASHER,LOCK,SPLIT RING- .168 ID, .296 OD	2	
- 30	257189	. NUT,HEX- 8-32	2	
- 31	510468	. WASHER,CUPPED- 1/5IN X .029 DIA	4	
- 32	321603	. WASHER,INSULATING 5/8 OD X 0.031 THK	4	
- 33	5703265	. BRACKET-RESISTOR MTG	2	
- 34	251970	. SCREW-MACH BD. HD. 4-40 X 1/4 LG	4	
- 35	56722	. WASHER,LOCK-EXT TEETH NO. 6	4	
- 36	334921	. TERMINAL-RING,18-22 AWG,#6 HOLE,INS	2	
- 37	477974	. CAPACITOR,FXD,FILM- 0.47MFD P/M 10% 400V	2	
- 38	5261459	. TERMINAL,STANDOFF	2	
- 39	28413	. SCREW,MACH-BIND HD 10-32 X 5/16 LG	6	
- 40	2572728	. BUS BAR-3 POS	2	
- 41	80651	. SCREW,THD CUTTING-PAN HD 6-32 X 0.375 LG	8	
- 42	473531	. INSULATOR	4	
- 43	5261445	. COIL,RF	2	
- 44	3960	. NUT,PLAIN,HEX- 1/4-20 X 7/16 FL W	4	
- 45	76574	. LOCKWASHER-EXT TOOTH ID .267 X OD .510	4	
- 46	5703259	. BUS BAR-CAPACITOR	4	
- 47	161351	. WASHER,PLAIN FLAT	2	
- 48	2572729	. PLATE,CAPACITOR MTG	1	
- 49	332620	. SCREW,MACH-BIND HD 10-32 X 1/2 LG	2	
- 49A	2572789	. SCREW-MACHINE FILLESTER HEAD 6-32 X 6.50	2	
- 49B	257986	. WASHER,FLAT NO. 6	2	
- 49C	6364	. WASHER,LOCK-SPLIT NO. 6 X 1/4 OD	2	
- 49D	257187	. NUT,PLAIN,HEX- 6-32 X 3/8 FL W	2	
- 50	5261388	. CAPACITOR,COMMUTATING-2 UF 400VDC	3	
- 51	5703211	. STAND-OFF	2	
- 52	332620	. SCREW,MACH-BIND HD 10-32 X 1/2 LG	2	
- 53	730432	. GROMMET,CATERPILLAR	AR	
- 54	2572724	. CHASSIS,INVERTER SECTION	1	
- 55	32042	. SCREW, MACH BIND. HD 10-32 X 3/8 LG.	4	
- 56	55918	. SCREW,MACH-BIND HD 10-32 X 5/8 LG	2	

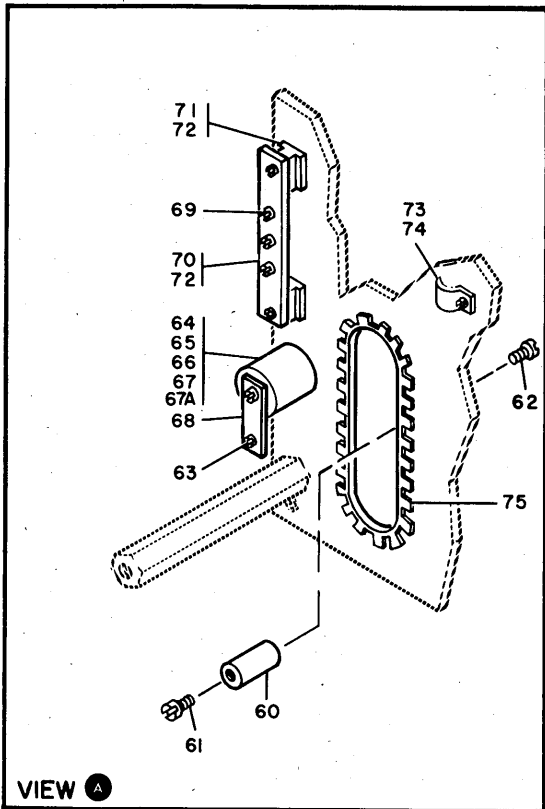
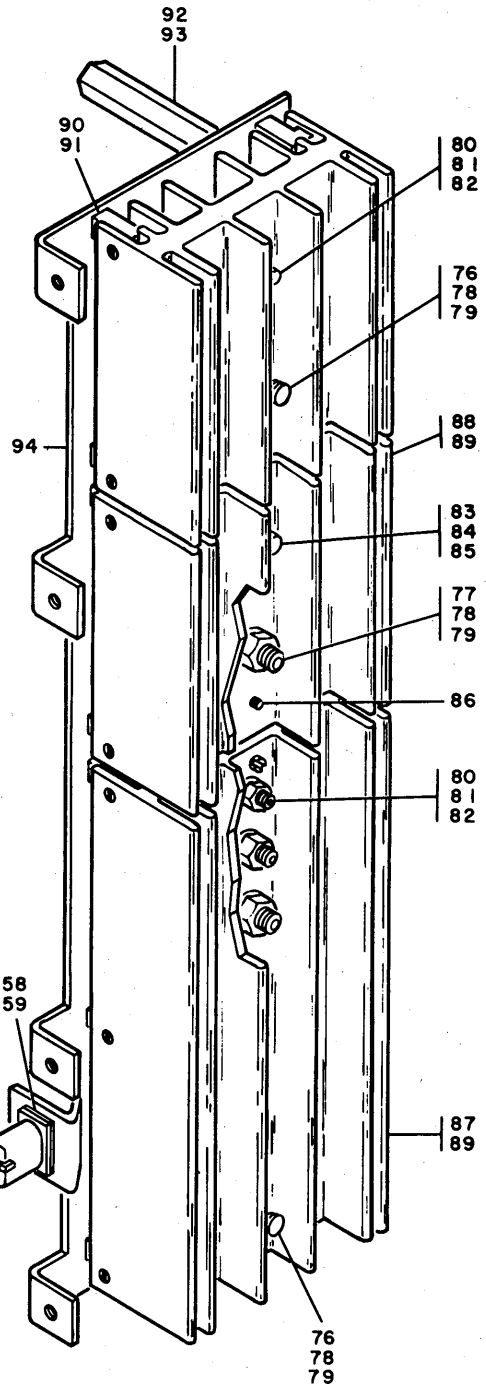
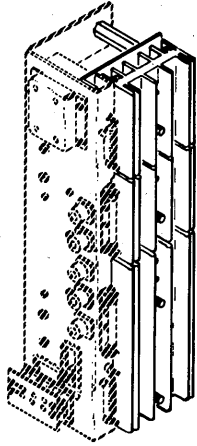

FIGURE 28. 75 AMP INVERTER SECTION ASSEMBLY. (SHEET 2 OF 2, INDEX NOS. 57-94)

LIST 28. 75 AMP INVERTER SECTION ASSEMBLY

FIGURE- INDEX NUMBER	PART NUMBER	DESCRIPTION	1 2 3 4				UNITS PER ASM.	USABLE ON CODE
28 - 57	450957	. CONNECTOR, PLUG, ELECTRICAL, FEMALE					1	
- 58	317286	. CONNECTOR, RECP, ELEC- 8 MALE CONTACTS					1	
- 59	38348	. SCREW, MACH-FIL HD 6-32 X 0.188 LG			ATT PT		2	
- 60	5703206	. STANDOFF					6	
- 61	38235	. SCREW, MACH-BIND HD 6-32 X 0.312 LG			ATT PT		6	
- 62	322550	. SCREW, MACH, BIND HD- 6-32 X .5 LG			ATT PT		6	
- 63	28413	. SCREW, MACH-BIND HD 10-32 X 5/16 LG					1	
- 64	5712043	. STUD, EXTENSION					2	
- 65	486036	. SCREW			ATT PT		2	
- 66	76574	. LOCKWASHER-EXT TOOTH ID .267 X OD .510			ATT PT		4	
- 67	90261	. SCREW, MACH-BIND HD 1/4-20 X 0.438 LG			ATT PT		2	
- 68	5703230	. TAB-BUS BAR					2	
- 69	28413	. SCREW, MACH-BIND HD 10-32 X 5/16 LG					6	
- 70	5261466	. BUS BAR					2	
- 71	473531	. INSULATOR					4	
- 72	80651	. SCREW, THD CUTTING-PAN HD 6-32 X 0.375 LG			ATT PT		8	
- 73	472707	. CLAMP					3	
- 74	91610	. SCREW, THD CTG-BIND HD 6-32 X 1/2 LG			ATT PT		3	
- 75	730432	. GROMMET, CATERPILLAR					AK	
- 76	5261454	. SEMICONDUCTOR DEVICE-CONTROLLED RECT					2	
- 77	5261457	. SEMICONDUCTOR DEVICE-CONTROLLED RECT					2	
- 78	18272	. NUT, PLAIN, HEX- 1/2-20 X 11/16 FL W			ATT PT		4	
- 79	130987	. WASHER, LOCK-SPLIT 0.509 ID X 0.879 OD			ATT PT		4	
- 80	5214094	. RECTIFIER, SILICON-12A, 1000V					2	
- 81	11598	. NUT, PLAIN-HEX 10-32 X 3/8 FL W			ATT PT		2	
- 82	9092	. WASHER-LOCK, SPLIT RING, .194 ID .337OD			ATT PT		2	
- 83	5213925	. RECTIFIER					2	
- 84	160017	. NUT, PLAIN, HEX- 1/4-28 X 7/16 FL W			ATT PT		2	
- 85	6935	. WASHER, LOCK-SPLIT 1/4 X 0.493 OD			ATT PT		2	
- 86	55918	. SCREW, MACH-BIND HD 10-32 X 5/8 LG					3	
- 87	2572727	. HEATSINK					1	
- 88	2572726	. HEATSINK					2	
- 89	255629	. SCREW, THD CTG-FL CSK HD NO. 6 X 1/2 LG			ATT PT		14	
- 90	5762034	. INSULATOR, HEATSINK					14	
- 91	91610	. SCREW, THD CTG-BIND HD 6-32 X 1/2 LG			ATT PT		14	
- 92	2572733	. SPACER					2	
- 93	55918	. SCREW, MACH-BIND HD 10-32 X 5/8 LG			ATT PT		2	
- 94	2572725	. PLATE, HEAT SINK MTG					1	

FOR PARTS
NOT SHOWN
SEE FIG. 25

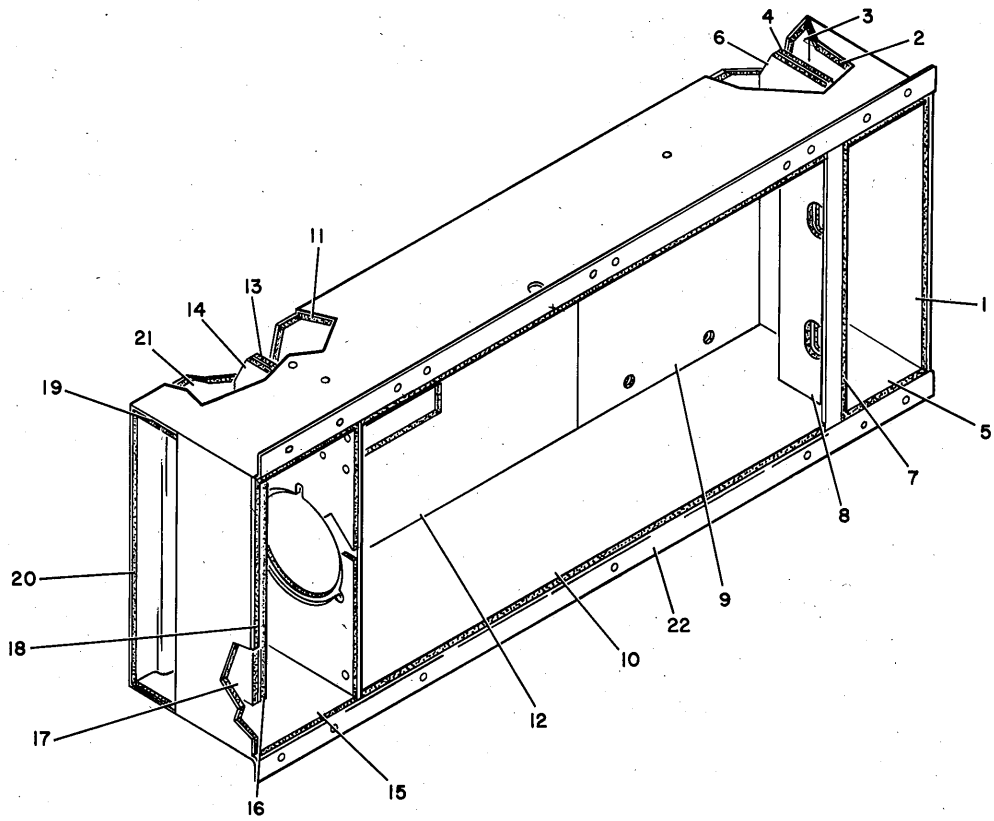

FIGURE 29. TUB AND LINER ASSEMBLY.

LIST 29. TUB AND LINER ASSEMBLY

FIGURE- INDEX NUMBER	PART NUMBER	DESCRIPTION	UNITS PER ASM.	USABLE ON CODE
29 -	2611714	TUB AND LINER ASSEMBLY FOR NEXT HIGHER ASM, SEE FIGURE 25-103	REF	
- 1	5261553	. LINING-FELT	1	
- 2	5261557	. LINING-FELT	1	
- 3	5261556	. LINING-FELT	1	
- 4	5261552	. LINING-FELT	1	
- 5	5261565	. LINING-FELT	1	
- 6	5261549	. LINING-FELT	1	
- 7	5261555	. LINING-FELT	1	
- 8	5261554	. LINING-FELT	1	
- 9	5261558	. LINING-FELT	1	
- 10	5261560	. LINING-FELT	1	
- 11	5261559	. LINING-FELT	1	
- 12	5261550	. LINING-FELT	1	
- 13	5261562	. LINING-FELT	1	
- 14	5261561	. LINING-FELT	1	
- 15	5261566	. LINING-FELT	1	
- 16	5261549	. LINING-FELT	1	
- 17	5261552	. LINING-FELT	1	
- 18	5261553	. LINING-FELT	1	
- 19	5261563	. LINING-FELT	1	
- 20	5261556	. LINING-FELT	1	
- 21	5261551	. LINING-FELT	1	
- 22	2611713	. TUB	1	

FOR PARTS
NOT SHOWN
SEE FIG. 22

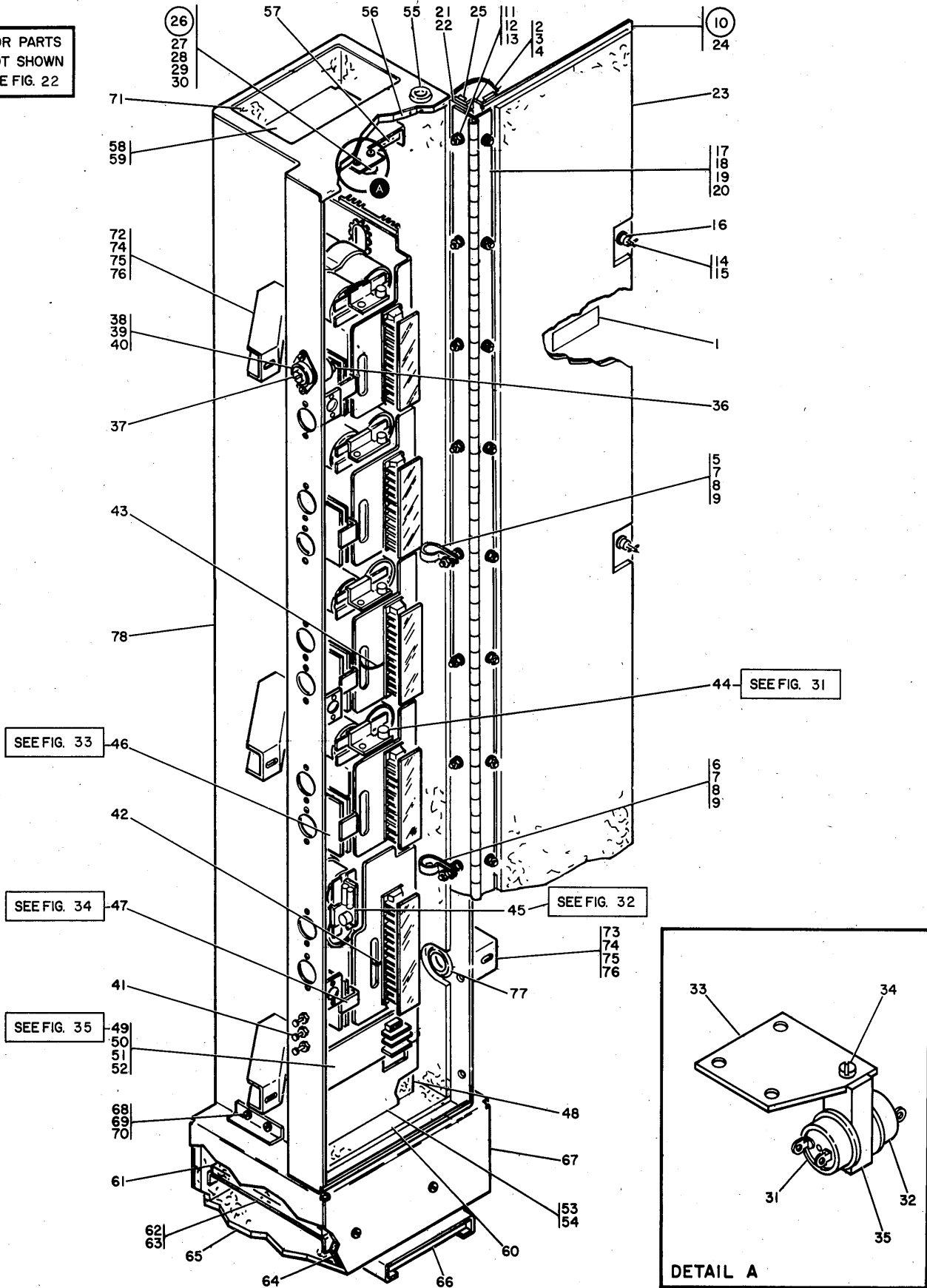

FIGURE 30. POWER TUB ASSEMBLY.

LIST 30. POWER TUB ASSEMBLY

FIGURE- INDEX NUMBER	PART NUMBER	DESCRIPTION	UNITS PER ASM.	USABLE ON CODE
30 -	5781311	POWER TUB ASSEMBLY FOR NEXT HIGHER ASM, SEE FIGURE 22-88	REF	
- 1	369207	. LABEL, VOLTAGE	1	
- 2	5236967	. JUMPER ASM-GRN/YEL 6 IN. 10AWG 1 LUG EA FOR COMPONENT PARTS SEE FIG. 59-34A	1	
- 3	32042	. SCREW, MACH BIND. HD 10-32 X 3/8 LG. ATT PT	2	
- 4	56079	. WASHER, LOCK-EXT T .195 ID .410 OD ATT PT	2	
- 5	350663	. CLAMP, CABLE	1	
- 6	327921	. CLAMP, CABLE	1	
- 7	438586	. SCREW, MACH-UNDRCT BIND HD 8-32 X 7/8 LG ATT PT	2	
- 8	55901	. WASHER, LOCK-EXT TEETH NO. 8 X 0.381 OD ATT PT	2	
- 9	257189	. NUT, HEX- 8-32 ATT PT	2	
- 10	5722004	. DOOR ASSEMBLY, A/S ENCLOSURE	1	
- 11	25627	. SCREW-BD. HD 8-32 X .500 LG ATT PT	8	
- 12	55901	. WASHER, LOCK-EXT TEETH NO. 8 X 0.381 OD ATT PT	8	
- 13	257189	. NUT, HEX- 8-32 ATT PT	8	
- 14	124436	. . STUD, TURNLOCK FASTENER	3	
- 15	312575	. . RING, RETAINING- 0.4375 ID X 0.040 THK	3	
- 16	312573	. . EYELET, TURNLOCK FASTENER- 0.354 ID	3	
- 17	5722007	. . HINGE-DOOR	1	
- 18	25627	. . SCREW-BD. HD 8-32 X .500 LG ATT PT	10	
- 19	55901	. . WASHER, LOCK-EXT TEETH NO. 8 X 0.381 OD ATT PT	10	
- 20	257189	. . NUT, HEX- 8-32 ATT PT	10	
- 21	5722059	. . STRIP-RETAINING	1	
- 22	5722058	. . STRIP-GASKET	1	
- 23	5722006	. . LINER-DOOR	1	
- 24	5722005	. . DOOR-P/S ENCLOSURE	1	
- 25	5722059	. . STRIP-RETAINING	1	
- 26	5781486	. SWITCH ASSEMBLY-THERMAL	1	
- 27	338238	. SCREW, MACH-BD HD 4-40 NC X .3125 LG ATT PT	2	
- 28	257985	. WASHER, FLAT-NO. 4 X 0.250 OD X 0.028 THK ATT PT	2	
- 29	257984	. WASHER, LOCK-SPLIT 1/8 ID X 13/64 OD ATT PT	2	
- 30	37913	. NUT-HEX 4-40 X .250 ID ATT PT	2	
- 31	5403116	. . SWITCH	1	
- 32	5319910	. . THERMOSTAT	1	
- 33	5781487	. . BRACKET	1	
- 34	10170	. . SCREW, MACH-BIND HD 6-32 X 1/4 LG ATT PT	1	
- 35	5357072	. . SWITCH	1	
- 36	236849	. SCREW, MACH-BIND HD 10-32 X 0.250 LG	15	
- 37	32042	. SCREW, MACH BIND. HD 10-32 X 3/8 LG.	5	
- 38	5364225	. CAPACITOR, FIXED, MYLAR-0.5 UF 100V	10	
- 39	10170	. SCREW, MACH-BIND HD 6-32 X 1/4 LG ATT PT	20	
- 40	56722	. WASHER, LOCK-EXT TEETH NO. 6 ATT PT	20	
- 41	504189	. TERMINAL, INSULATED-FEED THRU	3	
- 42	2180978	. JUMPER ASSEMBLY, 5 INCHES LONG	10	
- 43	5722071	. JUMPER ASSEMBLY FOR COMPONENT PARTS SEE FIG. 59-36C	10	
- 44	5708902	. REMOTE O/V - O/C TERMINAL BOARD FOR DETAIL BREAKDOWN SEE FIGURE 31.	4	
- 45	5709004	. REMOTE O/V-O/C ASSEMBLY FOR DETAIL BREAKDOWN SEE FIGURE 32.	1	
- 46	5712020	. 3V AT 40 AMP MAGNETIC AMPLIFIER ASSEMBLY FOR DETAIL BREAKDOWN SEE FIGURE 33.	4	
- 47	5712040	. 6V AT 40 AMP MAGNETIC AMPLIFIER ASSEMBLY FOR DETAIL BREAKDOWN SEE FIGURE 34.	1	
- 48	5276313	. LINER, FAN HOUSING	1	
- 49	5722008	. FAN ASSEMBLY, P/S ENCLOSURE FOR DETAIL BREAKDOWN SEE FIGURE 35.	1	
- 50	32617	. SCREW, MACH-BIND HD 10-32 X 0.438 LG ATT PT	2	
- 51	56079	. WASHER, LOCK-EXT T .195 ID .410 OD ATT PT	2	
- 52	45690	. WASHER, FL - NO.10 X 7/16 OD X 1/32 THK ATT PT	2	
- 53	5276370	. HOUSING, FAN	1	
- 54	25627	. SCREW-BD. HD 8-32 X .500 LG ATT PT	2	
- 55	450821	. GROMMET, 5/16 1.D. X 13/16 O.D. X 5/16 THK	1	
- 56	5722012	. LINER-TOP	1	
- 57	5722021	. LINER-BAFFLE	1	
- 58	5722016	. BAFFLE	1	
- 59	25627	. SCREW-BD. HD 8-32 X .500 LG ATT PT	4	
- 60	5722013	. LINER-BOTTOM	1	
- 61	5722036	. LINER-BASE	1	
- 62	5722023	. BAFFLE-BASE	1	
- 63	811421	. SCREW-PAN HD 6-32X.500 LG ATT PT	4	
- 64	5722024	. LINER-SIDE	1	

LIST 30. POWER TUB ASSEMBLY

FIGURE- INDEX NUMBER	PART NUMBER	DESCRIPTION	UNITS PER ASM.	USABLE ON CODE
30 -	5722037	. LINER-BOTTOM	1	
- 66	5722010	. FILTER-AIR	1	
- 67	5722003	. FILTER BOX	1	
- 68	34512	. SCREW, BIND HD 8-32 X .375 LG ATT PT	4	
- 69	1090873	. WASHER, LOCK, SPLIT RING- .168 ID, .296 OD ATT PT	4	
- 70	22478	. WASHER, FL- 0.170 ID 0.375 OD 0.32 THK ATT PT	4	
- 71	5722011	. LINER-SIDE	1	
- 72	5722014	. BRACKET-MTG LH	3	
- 73	5722015	. BRACKET-MTG RH	3	
- 74	32617	. SCREW, MACH-BIND HD 10-32 X 0.438 LG ATT PT	18	
- 75	9092	. WASHER-LOCK, SPLIT RING, .194 ID .3370D ATT PT	18	
- 76	45690	. WASHER, FL - NO.10 X 7/16 OD X 1/32 THK ATT PT	18	
- 77	123077	. GROMMET, RUB-FOR 1-1/4 HOLE X 1/8 PNL	1	
- 78	5722002	. ENCLOSURE-POWER SUPPLY	1	

FOR PARTS
NOT SHOWN
SEE FIGS. 30 & 39

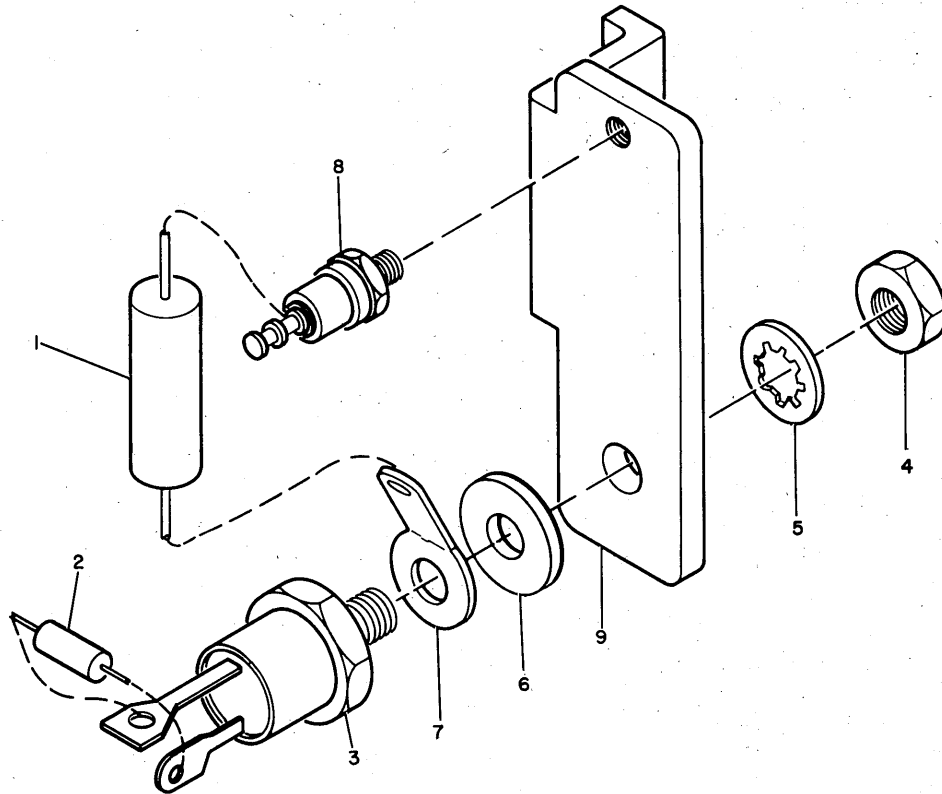

FIGURE 31. REMOTE O/V-O/C ASSEMBLY.

LIST 31. REMOTE O/V-O/C ASSEMBLY

FIGURE- INDEX NUMBER	PART NUMBER	DESCRIPTION				UNITS PER ASM.	USABLE ON CODE
		1	2	3	4		
31 -	5708902	REMOTE O/V - O/C TERMINAL BOARD FOR NEXT HIGHER ASM, SEE FIGURE 30-44 AND 39-27				REF	
- 1	207324	. RESISTOR,FXD,WH- 0.1 OHM P/M 5% 5W				1	
- 2	491228	. CAPACITOR,FXD,FILM- 0.01MF P/M 10% 100V				1	
- 3	595256	. SEMICONDUCTOR DEVICE,D10- 5V 2 AMP				1	
- 4	160017	. NUT,PLAIN,HEX- 1/4-28 X 7/16 FL W				1	
- 5	65756	. WASHER,LOCK-INT TEETH 0.267 ID X 0.4780D				1	ATT PT
- 6	3550	. WASHER,FL- 1/4 X 9/16 OD X 0.050 THK				1	ATT PT
- 7	322765	. TERMINAL,LUG				1	
- 8	5261459	. TERMINAL,STANDOFF				1	
- 9	5708926	. BRACKET				1	

FOR PARTS
NOT SHOWN
SEE FIGS.30&39

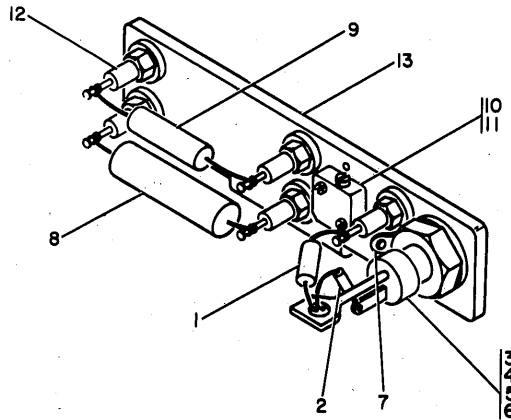

FIGURE 32. REMOTE O/V-O/C ASSEMBLY.

LIST 32. REMOTE O/V-O/C ASSEMBLY

FIGURE- INDEX NUMBER	PART NUMBER	DESCRIPTION				UNITS PER ASM.	USABLE ON CODE
		1	2	3	4		
32 -	5709004	REMOTE O/V-O/C ASSEMBLY FOR NEXT HIGHER ASM, SEE FIG. 30-45 AND 39-28				REF	
- 1	481467	• RESISTOR				1	
- 2	491228	• CAPACITOR, FXD, FILM- 0.01MF P/M 10% 100V				1	
- 3	595256	• SEMICONDUCTOR DEVICE, D10- 5V 2 AMP				1	
- 4	160017	• NUT, PLAIN, HEX- 1/4-28 X 7/16 FL W				1	ATT PT
- 5	65756	• WASHER, LOCK-INT TEETH 0.267 ID X 0.478OD				1	ATT PT
- 6	3550	• WASHER, FL- 1/4 X 9/16 OD X 0.050 THK				1	ATT PT
- 7	322765	• TERMINAL, LUG				1	
- 8	207324	• RESISTOR, FXD, WW- 0.1 OHM P/M 5% 5W				1	
- 9	479064	• RESISTOR, FXD, FLM, 90, 9 OHMS PORM 1%, 1/2W				1	
- 10	529214	• RESISTOR, VAR- 100 OHMS P/M 5% 1W				1	
- 11	438539	• SCREW, MACH-UNDRCT BIND HD 2-56 X 5/16 LG				2	ATT PT
- 12	5261459	• TERMINAL, STANDOFF				5	
- 13	5266286	• BRACKET				1	

FOR PARTS
NOT SHOWN
SEE FIG. 30&39

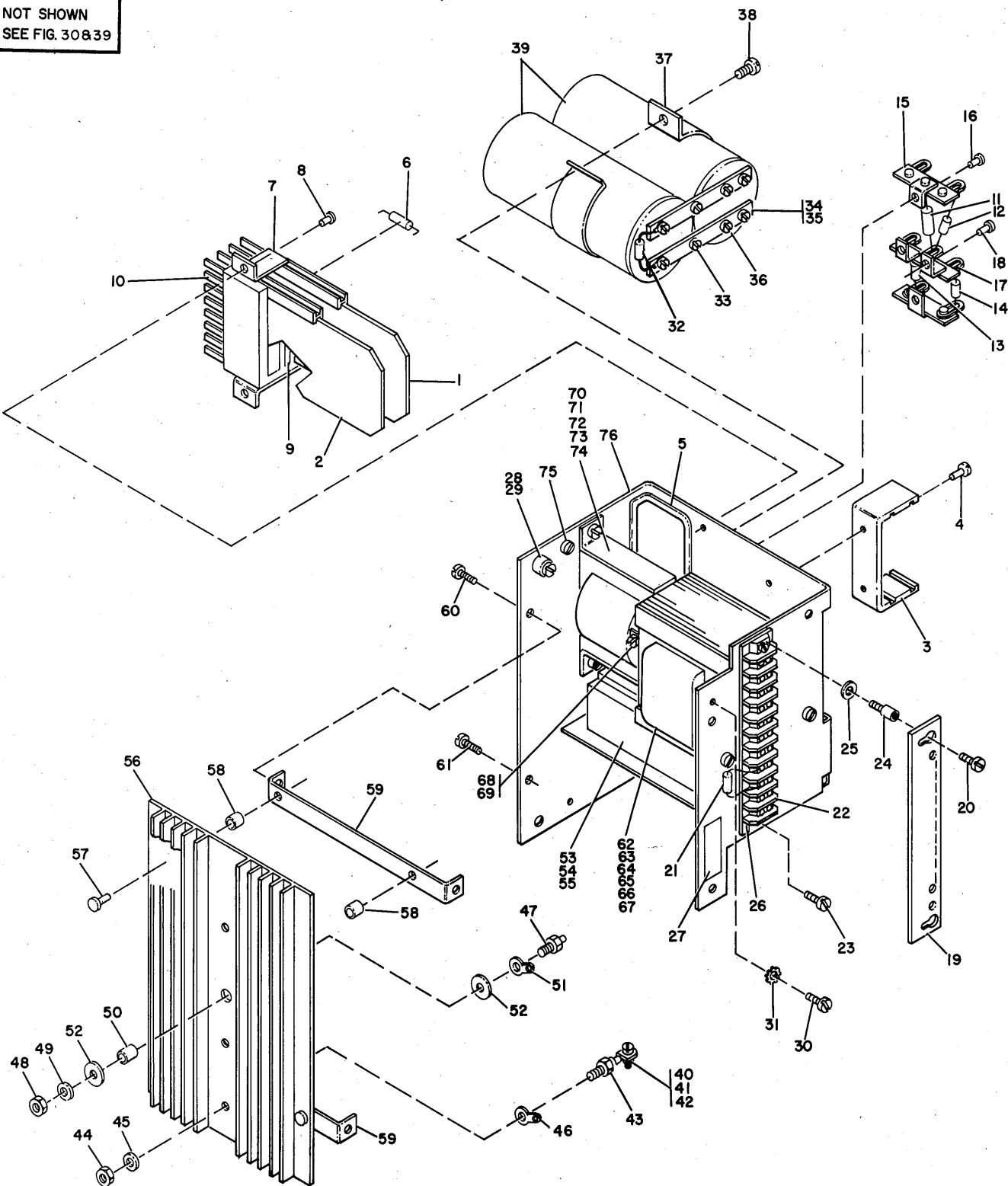

FIGURE 33. 3 VOLT AT 40 AMP MAGNETIC AMPLIFIER ASSEMBLY.

LIST 33. 3 VOLT AT 40 AMP MAGNETIC AMPLIFIER ASSEMBLY

FIGURE- INDEX NUMBER	PART NUMBER	DESCRIPTION	UNITS PER ASM.	USABLE ON CODE
33 -	5712020	3V AT 40 AMP MAGNETIC AMPLIFIER ASSEMBLY FOR NEXT HIGHER ASM, SEE FIG. 30-46 AND 39-31	REF	
- 1	372966	• CARD	1	
- 2	374772	• CARD ASM	1	
- 3	2572773	• HOLDER-CARD,SMS	1	
- 4	2572793	• RIVET	2	
- 5	518578	• RUBBER CHANNEL	AR	
- 6	5261789	• CAPACITOR ASSEMBLY,0.022UF,PORM 10 PCT	2	
- 7	2572845	• BRACKET	1	
- 8	2572793	• RIVET	2	
- 9	473547	• SPACER,1 X 2 3/8 IN .12 IN THICK	1	
- 10	216076	• TERMINAL BLOCK AND CONTACT ASSEMBLY	2	
- 11	509638	• RESISTOR,FXD 620 OHM P/M 5 PCT 2W	1	
- 12	335017	• RESISTOR,FIXED COMP 240 OHMS PM 5% 1W	1	
- 13	481439	• RESISTOR,FXD,FILM- 30.9 OHMS 1PCT 1/2W	1	
- 14	492448	• RESISTOR,FXD,FILM- 130 OHMS P/M 5% 2W	1	
- 15	314047	• TERMINAL BOARD- 2 SOLDER LUGS	2	
- 16	2572793	• RIVET	2	
- 17	301679	• TERMINAL BOARD-STRIP TYPE 3 TERM	1	
- 18	2572793	• RIVET	2	
- 19	352825	• COVER-TERMINAL 12 ON 40	1	
- 20	10170	• SCREW,MACH-BIND HD 6-32 X 1/4 LG	2	
- 21	5708939	• CAPACITOR ASM- 0.100MFD P/M 10% 100VDC	1	
- 22	323839	• TERMINAL BOARD- 12 DBL SCREW TERMINALS	1	
- 23	81693	• SCREW,MACH-BIND HD 6-32 X 3/8 LG	2	
- 24	5762407	• STUD,TAPPED MOUNTING	2	
- 25	257986	• WASHER,FLAT NO. 6	2	
- 26	806569	• STRIP,MARKER	1	
- 27	5261412	• LABEL	1	
- 28	5261315	• ADAPTER-CAPTIVE SCREW	2	
- 29	5261314	• SCREW,CAPTIVE- 10-32 X 1/2 LG	2	
- 30	10170	• SCREW,MACH-BIND HD 6-32 X 1/4 LG	1	
- 31	56722	• WASHER,LOCK-EXT TEETH NO. 6	1	
- 32	5738338	• RESISTOR ASSEMBLY- 12 OHM 2W	1	
- 33	236849	• SCREW,MACH-BIND HD 10-32 X 0.250 LG	4	
- 34	5261327	• BUS BAR	2	
- 35	32617	• SCREW,MACH-BIND HD 10-32 X 0.438 LG	4	
- 36	5240477	• SHIELD,CAPACITOR	2	
- 37	5261324	• BRACKET	1	
- 38	332620	• SCREW,MACH-BIND HD 10-32 X 1/2 LG	1	
- 39	5709381	• CAPACITOR,FIXED,ELECT-100,000 UF 6V	2	
- 40	81693	• SCREW,MACH-BIND HD 6-32 X 3/8 LG	1	
- 41	56722	• WASHER,LOCK-EXT TEETH NO. 6	1	
- 42	257187	• NUT,PLAIN,HEX- 6-32 X 3/8 FL W	1	
- 43	5213402	• RECTIFIER,SILICON	2	
- 44	160017	• NUT,PLAIN,HEX- 1/4-28 X 7/16 FL W	2	
- 45	3550	• WASHER,FL- 1/4 X 9/16 OD X 0.050 THK	2	
- 46	5762386	• TERMINAL	1	
- 47	5213402	• RECTIFIER,SILICON	2	
- 48	160017	• NUT,PLAIN,HEX- 1/4-28 X 7/16 FL W	2	
- 49	3550	• WASHER,FL- 1/4 X 9/16 OD X 0.050 THK	2	
- 50	473592	• INSULATOR	2	
- 51	5762386	• TERMINAL	2	
- 52	217017	• WASHER-INSULATING	8	
- 53	5261228	• REACTOR,SATURABLE	1	
- 54	5528	• SCREW,MACH BIND HD 8-32 X .625 LG	2	
- 55	54291	• SPACER- 0.191 ID X 3/8 OD X 3/8 THK	2	
- 56	2572766	• HEAT SINK	1	
- 57	2572865	• RIVET	4	
- 58	337549	• INSULATOR - HEAT SINK MOUNTING	4	
- 59	2572763	• BRACKET	2	
- 60	10170	• SCREW,MACH-BIND HD 6-32 X 1/4 LG	2	
- 61	38442	• SCREW,MACH-FL CSK HD 6-32 X 1/4 LG	2	
- 62	5261223	• TRANSFORMER,POWER- 2500CPS 409VA	1	
- 63	32617	• SCREW,MACH-BIND HD 10-32 X 0.438 LG	3	
- 64	45690	• WASHER, FL - NO.10 X 7/16 OD X 1/32 THK	3	
- 65	9092	• WASHER-LOCK,SPLIT RING, .194 ID .337OD	3	
- 66	11598	• NUT,PLAIN-HEX 10-32 X 3/8 FL W	3	
- 67	56079	• WASHER,LOCK-EXT T .195 ID .410 OD	1	
- 68	58207	• SCREW,MACH-UNDRCT BIND HD 8-32 X 1/4 LG	2	
- 69	55901	• WASHER,LOCK-EXT TEETH NO. 8 X 0.381 OD	2	
- 70	5261229	• CHOKE,FILTER	1	
- 71	316807	• SCREW,MACH-FH,NO. 6-32 X .375 LG	2	
- 72	6364	• WASHER,LOCK-SPLIT NO. 6 X 1/4 OD	2	
- 73	257187	• NUT,PLAIN,HEX- 6-32 X 3/8 FL W	2	
- 74	56722	• WASHER,LOCK-EXT TEETH NO. 6	1	
- 75	28413	• SCREW,MACH-BIND HD 10-32 X 5/16 LG	2	
- 76	2572765	• CHASSIS	1	

FOR PARTS
NOT SHOWN
SEE FIG. 30 & 39

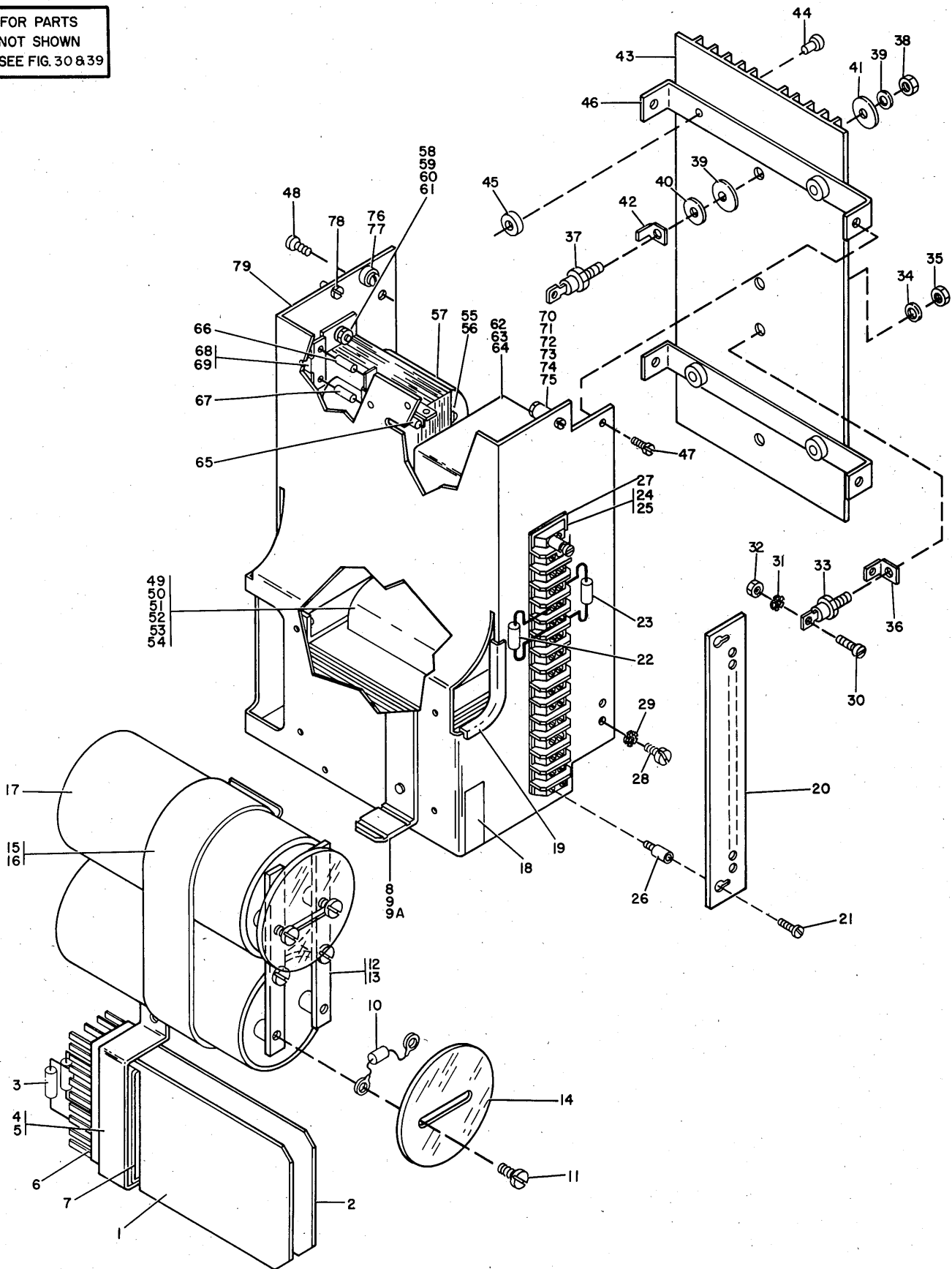

FIGURE 34. 6 VOLT DC AT 40 AMP MC POWER SUPPLY ASSEMBLY.

LIST 34. 6 VOLT DC AT 40 AMP MC POWER SUPPLY ASSEMBLY

FIGURE- INDEX NUMBER	PART NUMBER	DESCRIPTION	UNITS PER ASM.	USABLE ON CODE
34 -	5712040	6V AT 40 AMP MAGNETIC AMPLIFIER ASSEMBLY FOR NEXT HIGHER ASM, SEE FIG. 30-47 AND 39-32	REF	
- 1	372975	. CARD	1	
- 2	374772	. CARD ASM	1	
- 3	5261789	. CAPACITOR ASSEMBLY, 0.022UF, PORM 10 PCT	2	
- 4	2572845	. BRACKET	1	
- 5	2572793	. RIVET	2	ATT PT
- 6	216076	. TERMINAL BLOCK AND CONTACT ASSEMBLY	2	
- 7	473547	. SPACER, 1 X 2 3/8 IN .12 IN THICK	1	
- 8	2572773	. HOLDER-CARD, SMS	1	
- 9	2572793	. RIVET	2	ATT PT
- 10	2572833	. RESISTOR ASSEMBLY	1	
- 11	236849	. SCREW, MACH-BIND HD 10-32 X 0.250 LG	4	
- 12	5261327	. BUS BAR	2	
- 13	332620	. SCREW, MACH-BIND HD 10-32 X 1/2 LG	4	ATT PT
- 14	5240477	. SHIELD, CAPACITOR	2	
- 15	5261326	. BRACKET-CAPACITOR	1	
- 16	32617	. SCREW, MACH-BIND HD 10-32 X 0.438 LG	1	ATT PT
- 17	5261247	. CAPACITOR, ELEC-60,000 UF P/M 10% 8VDC	2	
- 18	5261412	. LABEL	1	
- 19	518578	. RUBBER CHANNEL	1	
- 20	533360	. COVER-TERMINAL BOARD	1	
- 21	10170	. SCREW, MACH-BIND HD 6-32 X 1/4 LG	2	ATT PT
- 22	5261779	. CAPACITOR ASSEMBLY, 0.015UF, 100VDC	1	
- 23	5708939	. CAPACITOR ASM- 0.100MFD P/M 10% 100VDC	1	
- 24	82353	. TERMINAL BOARD- 14 DBL SCREW TERMINALS	1	
- 25	35739	. SCREW, MACH-BIND HD 6-32 X 15/16 LG	2	ATT PT
- 26	5762407	. STUD, TAPPED MOUNTING	2	
- 27	351228	. STRIP-TB MARKER	1	
- 28	55726	. SCREW, MACH-BIND HD 6-32 X .188 LG	1	
- 29	56722	. WASHER, LOCK-EXT TEETH NO. 6	1	
- 30	38235	. SCREW, MACH-BIND HD 6-32 X 0.312 LG	1	
- 31	56722	. WASHER, LOCK-EXT TEETH NO. 6	1	
- 32	257187	. NUT, PLAIN, HEX- 6-32 X 3/8 FL W	1	
- 33	5213402	. RECTIFIER, SILICON	2	
- 34	3550	. WASHER, FL- 1/4 X 9/16 OD X 0.050 THK	2	ATT PT
- 35	160017	. NUT, PLAIN, HEX- 1/4-28 X 7/16 FL W	2	ATT PT
- 36	5762386	. TERMINAL	1	
- 37	5213402	. RECTIFIER, SILICON	2	
- 38	160017	. NUT, PLAIN, HEX- 1/4-28 X 7/16 FL W	2	ATT PT
- 39	3550	. WASHER, FL- 1/4 X 9/16 OD X 0.050 THK	2	ATT PT
- 40	217017	. WASHER-INSULATING	8	ATT PT
- 41	473592	. INSULATOR	2	ATT PT
- 42	5762386	. TERMINAL	2	
- 43	2572828	. HEATSINK	1	
- 44	2572865	. RIVET	4	ATT PT
- 45	337549	. INSULATOR - HEAT SINK MOUNTING	4	ATT PT
- 46	2572763	. BRACKET	2	
- 47	10170	. SCREW, MACH-BIND HD 6-32 X 1/4 LG	2	ATT PT
- 48	38442	. SCREW, MACH-FL CSK HD 6-32 X 1/4 LG	2	ATT PT
- 49	5261243	. TRANSFORMER, POWER	1	
- 50	236849	. SCREW, MACH-BIND HD 10-32 X 0.250 LG	3	ATT PT
- 51	28413	. SCREW, MACH-BIND HD 10-32 X 5/16 LG	1	ATT PT
- 52	45690	. WASHER, FL - NO. 10 X 7/16 OD X 1/32 THK	4	ATT PT
- 53	56121	. WASHER, LOCK-INT TEETH NO. 10 X 0.381 OD	4	ATT PT
- 54	56079	. WASHER, LOCK-EXT T .195 ID .410 OD	1	ATT PT
- 55	58207	. SCREW, MACH-UNDRCT BIND HD 8-32 X 1/4 LG	2	
- 56	55901	. WASHER, LOCK-EXT TEETH NO. 8 X 0.381 OD	2	
- 57	5261229	. CHOKE, FILTER	1	
- 58	38443	. SCREW, MACH-FL CSK HD 6-32 X 5/16 LG	2	ATT PT
- 59	6364	. WASHER, LOCK-SPLIT NO. 6 X 1/4 OD	2	ATT PT
- 60	56722	. WASHER, LOCK-EXT TEETH NO. 6	1	ATT PT
- 61	257187	. NUT, PLAIN, HEX- 6-32 X 3/8 FL W	2	ATT PT
- 62	5261248	. REACTOR, SATURABLE	1	
- 63	221790	. SCREW, MACH-BIND HD 8-32 X 3/16 LG	1	ATT PT
- 64	38450	. SCREW, MACH-FH 8-32 X 3/16 LG	1	ATT PT
- 65	335017	. RESISTOR, FIXED COMP 240 OHMS PM 5% 1W	1	
- 66	492448	. RESISTOR, FXD, FILM- 130 OHMS P/M 5% 2W	1	
- 67	481439	. RESISTOR, FXD, FILM- 30.9 OHMS IPCT 172W	1	
- 68	314047	. TERMINAL BOARD- 2 SOLDER LUGS	3	
- 69	2572793	. RIVET	3	ATT PT
- 70	443052	. RESISTOR-WIREWOUND, 350 OHMS PM 5 PCT	1	
- 71	438570	. SCREW, MACH-BIND HD 6-32 X 1-1/2 LG	1	ATT PT
- 72	257986	. WASHER, FLAT NO. 6	1	ATT PT
- 73	6364	. WASHER, LOCK-SPLIT NO. 6 X 1/4 OD	1	ATT PT
- 74	257187	. NUT, PLAIN, HEX- 6-32 X 3/8 FL W	1	ATT PT
- 75	203801	. INSULATOR WASH- 0.172 ID 9/16 OD 1/16 THK	2	ATT PT
- 76	5261314	. SCREW, CAPTIVE- 10-32 X 1/2 LG	2	
- 77	5261315	. ADAPTER-CAPTIVE SCREW	2	
- 78	28413	. SCREW, MACH-BIND HD 10-32 X 5/16 LG	2	
- 79	2572829	. CHASSIS	1	

FOR PARTS
NOT SHOWN
SEE FIG 30

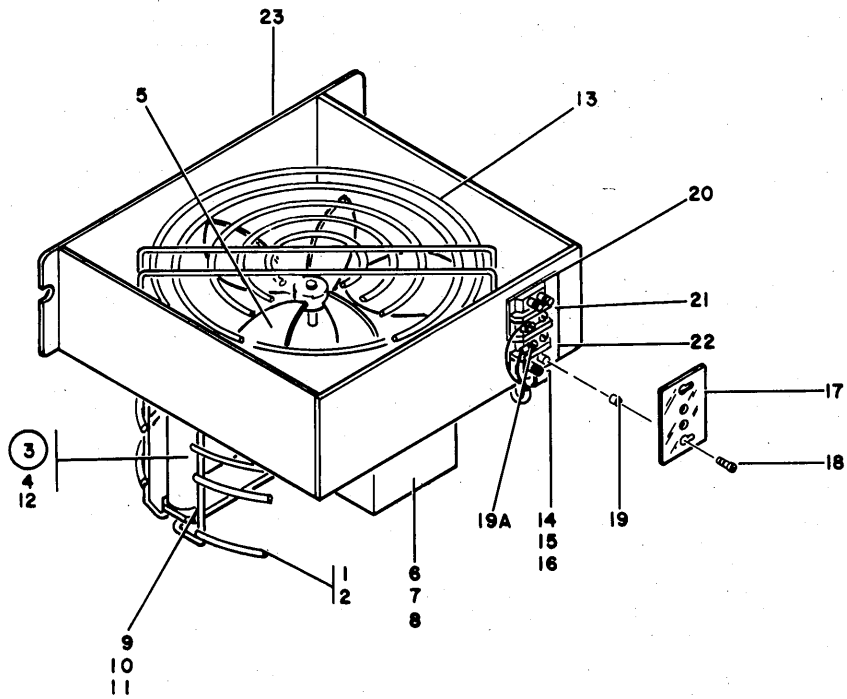
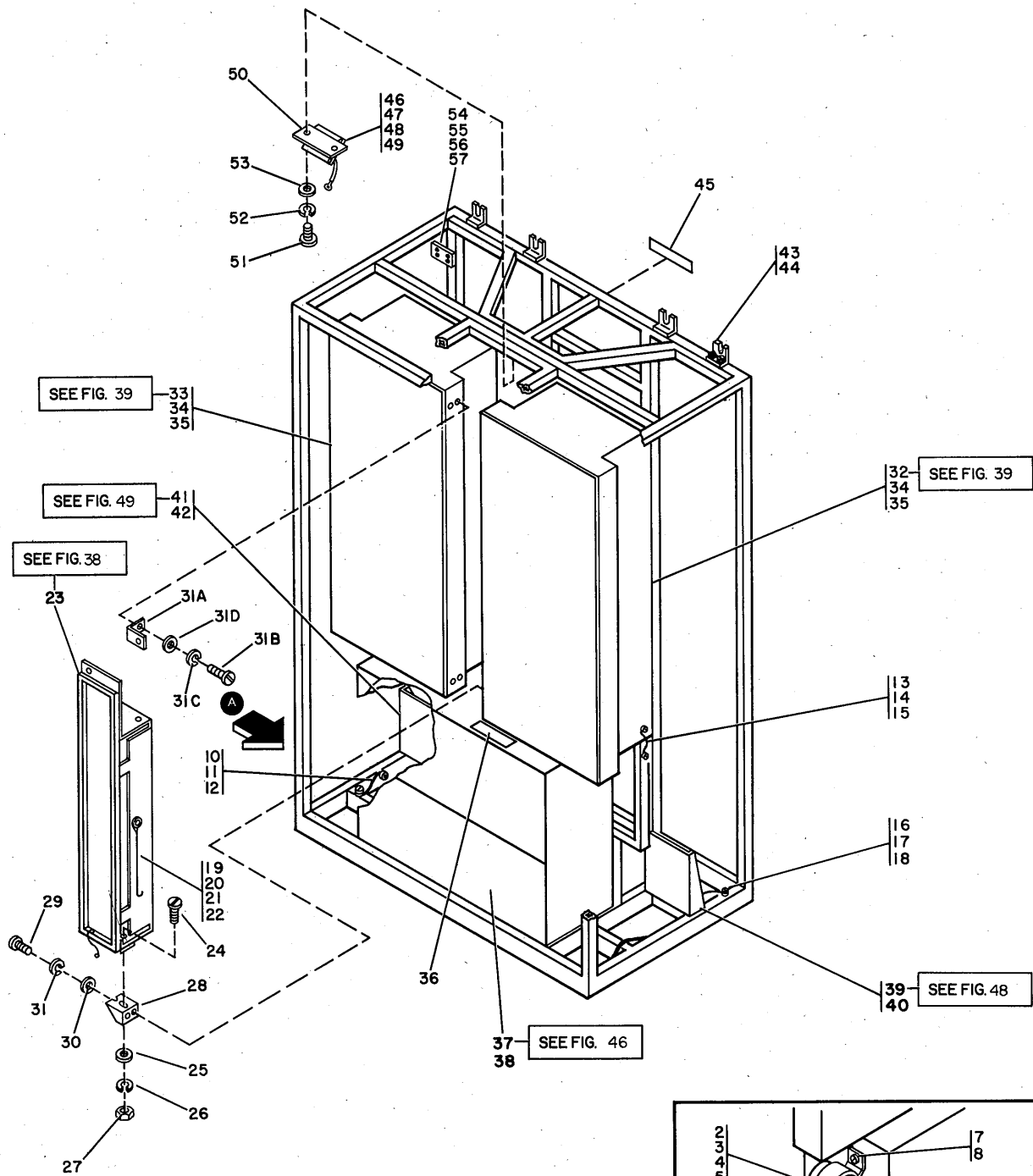

FIGURE 35. FAN ASSEMBLY.

LIST 35. FAN ASSEMBLY

FIGURE- INDEX NUMBER	PART NUMBER	DESCRIPTION	UNITS PER ASM.	USABLE ON CODE
35 -	5722008	FAN ASSEMBLY, P/S ENCLOSURE FOR NEXT HIGHER ASM, SEE FIGURE 30-49	REF	
- 1	5357060	. GUARD 5 IN FAN	1	
- 2	813706	. SCREW, SELF TAPPING- WASH HD 10-32 X 3/8	2	
- 3	5357050	. FAN ASM- 208/230V 60 HZ	1	
- 4	32042	. SCREW, MACH BIND. HD 10-32 X 3/8 LG.	2	
- 5	5357066	. . BLADE	1	
- 6	5357067	. . MOTOR 208V/230V 60CY 220V 50CY	1	
- 7	130434	. . SCREW-MACH, SLOTTED HEX HD NO.10-32 X.375	2	
- 8	56079	. . WASHER, LOCK-EXT T .195 ID .410 OD	2	
- 9	5357062	. . BRACKET	1	
- 10	130434	. . SCREW-MACH, SLOTTED HEX HD NO.10-32 X.375	2	
- 11	56079	. . WASHER, LOCK-EXT T .195 ID .410 OD	2	
- 12	5357061	. . ORIFICE	1	
- 13	5357059	. GUARD TOP	1	
- 14	2102364	. CLAMP, LOOP- 0.220 ID 0.170 DIA MTG HOLE	1	
- 15	38235	. SCREW, MACH-BIND HD 6-32 X 0.312 LG	1	
- 16	56722	. WASHER, LOCK-EXT TEETH NO. 6	1	
- 17	5319909	. COVER-TERM BLOCK 15A 2 POSITION	1	
- 18	322552	. SCREW, MACH-BIND HD 6-32 X 7/8 LG	2	
- 19	316187	. SPACER- 0.186 ID X 1/4 OD X 5/16 THK	2	
- 19A	334921	. TERMINAL-RING, 18-22 AWG, #6 HOLE, INS	2	
- 20	323836	. BLOCK-TERMINAL	1	
- 21	35739	. SCREW, MACH-BIND HD 6-32 X 15/16 LG	2	
- 22	5318920	. STRIP T B MARKER	1	
- 23	5722009	. HOUSING-FAN MTG	1	



SEE LIST 58
FOR CABLES

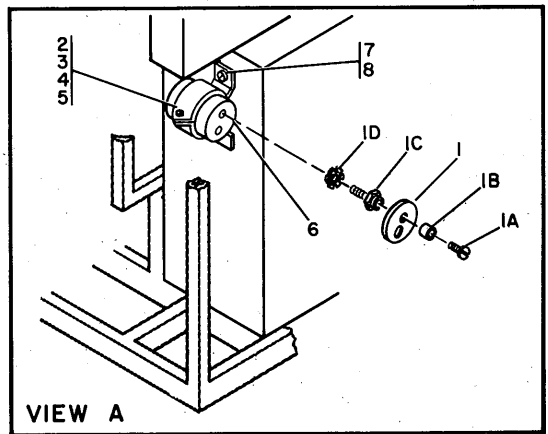

FIGURE 37. POWER FRAME ASSEMBLY-FRAME 01. (SHEET 1 OF 2. INDEX NOS. 1-57)

LIST 37. POWER FRAME ASSEMBLY-FRAME 01

FIGURE-INDEX NUMBER	PART NUMBER	DESCRIPTION	UNITS PER ASM.	USABLE ON CODE
37 -	5781303	FRAME ASM PWR WALL	REF	
- 1	631769	. SHIELD,CAPACITOR	1	
- 1A	5791040	. SCREW-BINDING WASHER ATT PT	2	
- 1B	5791041	. SPACER	2	
- 1C	5726716	. STANDOFF,SHOULDER	2	
- 1D	56079	. WASHER,LOCK-EXT T .195 ID .410 OD ATT PT	2	
- 2	332620	. SCREW,MACH-BIND HD 10-32 X 1/2 LG	1	
- 3	45690	. WASHER, FL - NO.10 X 7/16 OD X 1/32 THK	2	
- 4	56079	. WASHER,LOCK-EXT T .195 ID .410 OD	1	
- 5	11598	. NUT,PLAIN-HEX 10-32 X 3/8 FL W	1	
- 6	2181284	. CAPACITOR-ELECTROLYTIC DC CAN TYPE	1	
- 7	5729093	. CLAMP-CAPACITOR	1	
- 8	58207	. SCREW,MACH-UNDRCT BIND HD 8-32 X 1/4 LG ATT PT	2	
- 10	5236967	. JUMPER ASM-GRN/YEL 6 IN. 10AWG 1 LUG EA FOR COMPONENT PARTS SEE FIG. 59-34A	1	
- 11	32042	. SCREW, MACH BIND. HD 10-32 X 3/8 LG. ATT PT	1	
- 12	56079	. WASHER,LOCK-EXT T .195 ID .410 OD ATT PT	1	
- 13	5236967	. JUMPER ASM-GRN/YEL 6 IN. 10AWG 1 LUG EA FOR COMPONENT PARTS SEE FIG. 59-34A	2	
- 14	32042	. SCREW, MACH BIND. HD 10-32 X 3/8 LG. ATT PT	2	
- 15	56079	. WASHER,LOCK-EXT T .195 ID .410 OD ATT PT	2	
- 16	5723632	. JUMPER ASM FOR COMPONENT PARTS SEE FIG. 59-36A	2	
- 17	34512	. SCREW,BIND.HD 8-32 X .375 LG ATT PT	2	
- 18	55901	. WASHER,LOCK-EXT TEETH NO. 8 X 0.381 OD ATT PT	4	
- 19	5723672	. ROPE SUPPORT ASM	1	
- 20	71776	. SCREW - FL HD - 1/4-20 X 7/8 LG. ATT PT	2	
- 21	6935	. WASHER,LOCK-SPLIT 1/4 X 0.493 OD ATT PT	2	
- 22	3960	. NUT,PLAIN,HEX- 1/4-20 X 7/16 FL W ATT PT	2	
- 23	5781318	. RELAY GATE	1	
- 24	367	FOR DETAIL BREAKDOWN SEE FIGURE 38		
- 25	45690	. SCREW,MACH-FL CSK HD 10-32 X 5/8 LG ATT PT	4	
- 26	9092	. WASHER, FL - NO.10 X 7/16 OD X 1/32 THK ATT PT	4	
- 27	11598	. WASHER-LOCK,SPLIT RING, .194 ID .3370D ATT PT	4	
- 28	5722121	. NUT,PLAIN-HEX 10-32 X 3/8 FL W ATT PT	4	
- 29	332620	. BRACKET,MOUNTING,HINGE	2	
- 30	45690	. SCREW,MACH-BIND HD 10-32 X 1/2 LG ATT PT	4	
- 31	9092	. WASHER, FL - NO.10 X 7/16 OD X 1/32 THK ATT PT	4	
- 31A	5722122	. WASHER-LOCK,SPLIT RING, .194 ID .3370D ATT PT	4	
- 31B	332620	. BRACKET,MOUNTING,RECEPTACLE	1	
- 31C	9092	. SCREW,MACH-BIND HD 10-32 X 1/2 LG ATT PT	2	
- 31D	45690	. WASHER-LOCK,SPLIT RING, .194 ID .3370D ATT PT	2	
- 32	5781317	. POWER TUB ASSEMBLY RIGHT	1	
- 33	5781316	. POWER TUB ASSEMBLY LEFT FOR DETAIL BREAKDOWN SEE FIGURE 39	1	
- 34	5353301	. SCREW,THREAD FORMING- 1/4-20 X 5/8 LG ATT PT	12	
- 35	120571	. WASHER,FL- 1/4 X 5/8 OD X 1/16 THK ATT PT	12	
- 36	5781569	. PLATE-VOLTAGE	1	
- 37	5781319	. POWER BOX ASSEMBLY	1	
- 38	5353301	FOR DETAIL BREAKDOWN SEE FIGURE 46		
- 39	5781453	. SCREW,THREAD FORMING- 1/4-20 X 5/8 LG ATT PT	8	
- 40	25627	. I/O PANEL ASSEMBLY-RIGHT	1	
- 41	5781452	FOR DETAIL BREAKDOWN SEE FIGURE 48		
- 42	25627	. SCREW-BD. HD 8-32 X .500 LG ATT PT	2	
- 43	5372883	. BRACKET-TOP	4	
- 44	34512	. SCREW,BIND.HD 8-32 X .375 LG ATT PT	8	
- 45	2569395	. LABEL-WARNING	2	
- 46	5722080	. MOTOR,NEGATOR	1	
- 47	32617	. SCREW,MACH-BIND HD 10-32 X 0.438 LG ATT PT	2	
- 48	45690	. WASHER, FL - NO.10 X 7/16 OD X 1/32 THK ATT PT	2	
- 49	9092	. WASHER-LOCK,SPLIT RING, .194 ID .3370D ATT PT	2	
- 50	5722079	. BRACKET,NEGATOR	1	
- 51	25627	. SCREW-BD. HD 8-32 X .500 LG ATT PT	2	
- 52	1090873	. WASHER,LOCK,SPLIT RING- .168 ID, .296 OD ATT PT	2	
- 53	22478	. WASHER,FL- 0.170 ID C.375 OD 0.32 THK ATT PT	2	
- 54	5726736	. BRACKET-MTG	8	
- 55	32042	. SCREW, MACH BIND. HD 10-32 X 3/8 LG. ATT PT	16	
- 56	9092	. WASHER-LOCK,SPLIT RING, .194 ID .3370D ATT PT	16	
- 57	45690	. WASHER, FL - NO.10 X 7/16 OD X 1/32 THK ATT PT	16	

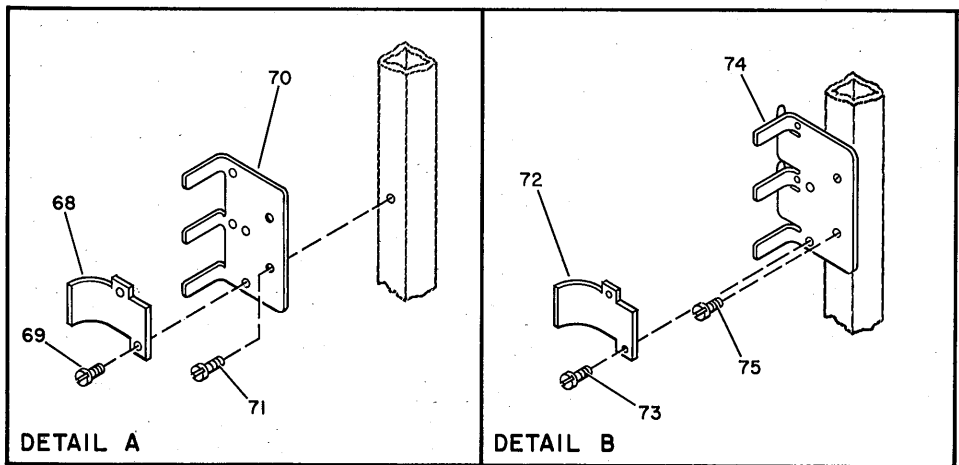
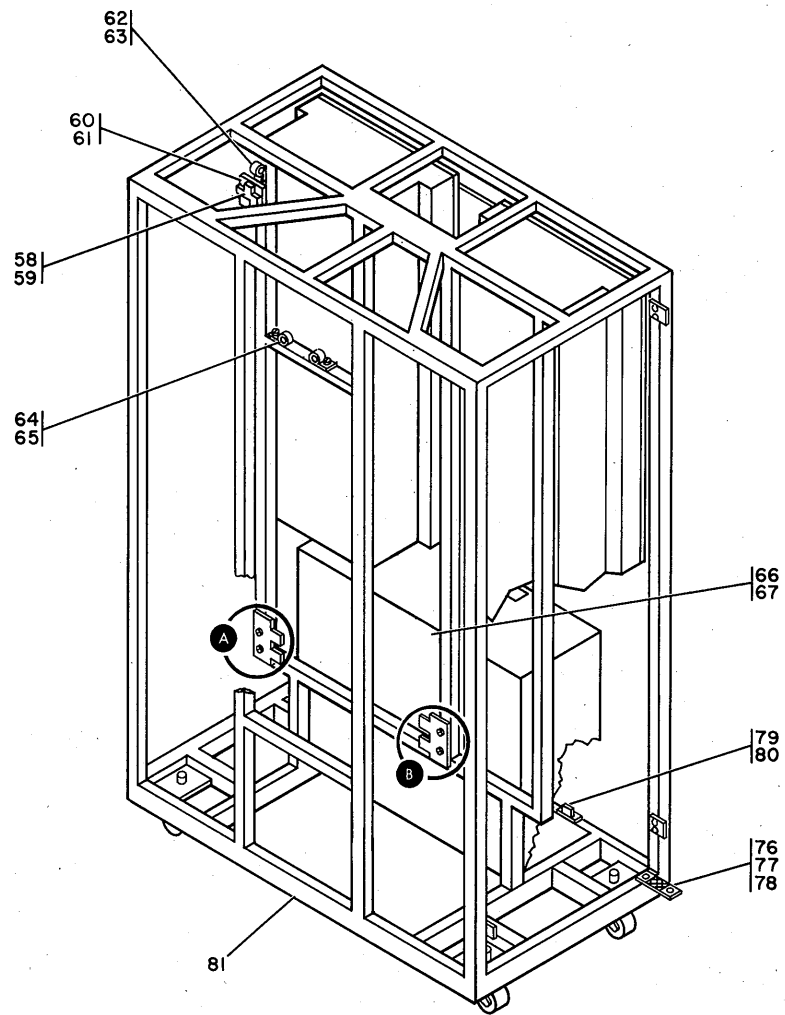

FIGURE 37. POWER FRAME ASSEMBLY-FRAME 01. (SHEET 2 OF 2. INDEX NOS. 58-81)

LIST 37. POWER FRAME ASSEMBLY-FRAME 01

FIGURE-INDEX NUMBER	PART NUMBER	DESCRIPTION				UNITS PER ASM.	USABLE ON CODE
37 - 58	5722125	• CLAMP-CABLE				4	
- 59	438588	• SCREW, MACH-UNDRCT BIND HD 8-32 X 1-1/4 ATT PT				8	
- 60	5723198	• BRACKET-CABLE				4	
- 61	4636	• SCREW, MACH-FL CSK HD 8-32 X 3/8 LG ATT PT				8	
- 62	5270166	• CLAMP-ADJUSTABLE				4	
- 63	34512	• SCREW, BIND. HD 8-32 X .375 LG ATT PT				4	
- 64	5270166	• CLAMP-ADJUSTABLE				1	
- 65	32042	• SCREW, MACH BIND. HD 10-32 X 3/8 LG. ATT PT				1	
- 66	532393	• CLAMP-ADJUSTABLE CABLE				1	
- 67	32042	• SCREW, MACH BIND. HD 10-32 X 3/8 LG. ATT PT				1	
- 68	5722125	• CLAMP-CABLE				60	
- 69	438588	• SCREW, MACH-UNDRCT BIND HD 8-32 X 1-1/4 ATT PT				120	
- 70	5722299	• PLATE				30	
- 71	4636	• SCREW, MACH-FL CSK HD 8-32 X 3/8 LG ATT PT				60	
- 72	5722125	• CLAMP-CABLE				4	
- 73	438588	• SCREW, MACH-UNDRCT BIND HD 8-32 X 1-1/4 ATT PT				8	
- 74	5722132	• BRACKET-CABLE				2	
- 75	4636	• SCREW, MACH-FL CSK HD 8-32 X 3/8 LG ATT PT				4	
- 76	5240500	• STRAP				2	
- 77	32042	• SCREW, MACH BIND. HD 10-32 X 3/8 LG. ATT PT				2	
- 78	56079	• WASHER, LOCK-EXT T .195 ID .410 OD ATT PT				4	
- 79	513669	• STRIKE-FRICTION LATCH				4	
- 80	10170	• SCREW, MACH-BIND HD 6-32 X 1/4 LG ATT PT				8	
- 81	5722101	• FRAME, POWER WALL				1	

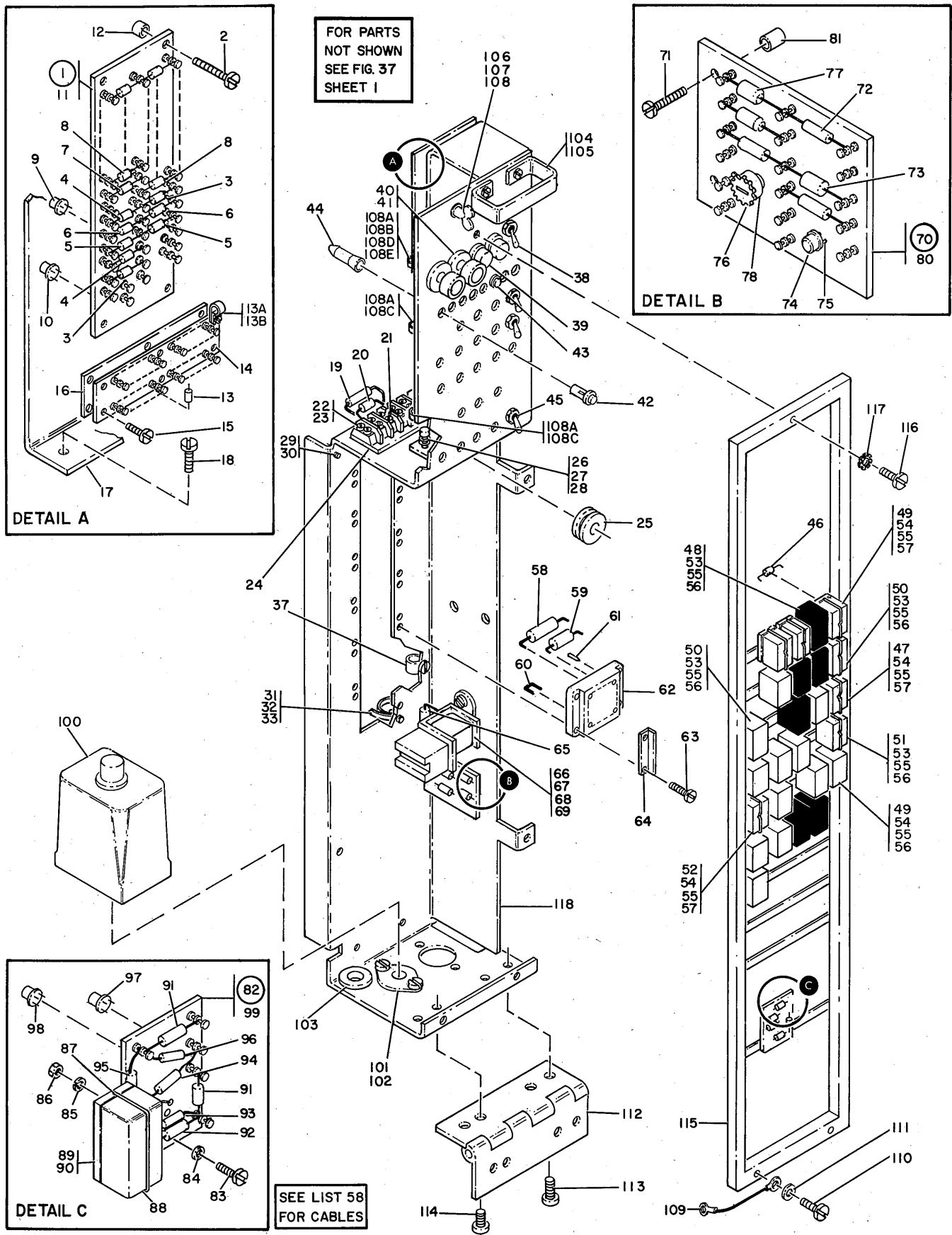

FIGURE 38. RELAY GATE HOUSING ASSEMBLY.

LIST 38. RELAY GATE HOUSING ASSEMBLY

FIGURE- INDEX NUMBER	PART NUMBER	DESCRIPTION	UNITS PER ASM.	USABLE ON CODE
38 -	5781318	RELAY GATE FOR NEXT HIGHER ASM, SEE FIGURE 37-23	REF	
- 1	5722133	• BOARD ASSEMBLY, COMPONENT	1	
- 2	322551	• SCREW, MACH-BIND HD 6-32X3/4 LG ATT PT	4	
- 3	317010	• RESISTOR, FXD, COMP- 430 OHMS P/M 5% 1/2W	2	
- 4	317001	• RESISTOR, FXD, COMP-1.1K P/M 5 PCT 1/2W	2	
- 5	317003	• RESISTOR, FXD, COMP- 47 OHMS P/M 5% 1/2W	2	
- 6	2414815	• SEMICONDUCTOR DEVICE, DIODE	2	
- 7	2111232	• SEMICONDUCTOR DEVICE, DIODE-TYPE AM	15	
- 8	300721	• RESISTOR, FXD, COMP- 10K P/M 5% 1/2W	2	
- 9	369654	• TRANSISTOR-NPN	2	
- 10	369652	• TRANSISTOR-PNP	2	
- 11	5276305	• TERMINAL BOARD	1	
- 12	5361886	• SPACER	4	
- 13	356740	• RESISTOR, FXD, COMP 270 OHMS P/M 10% 1/2W	10	
- 13A	2102364	• CLAMP, LOOP- 0.220 ID 0.170 DIA MTG HOLE	1	
- 13B	263550	• SCREW	1	
- 14	5781464	• TERMINAL BOARD	1	
- 15	438548	• SCREW, MACH-BIND HD 4-40 X 3/16 LG ATT PT	5	
- 16	5781465	• INSULATOR	1	
- 17	5781347	• BRACKET, RESISTOR MTG	1	
- 18	10170	• SCREW, MACH-BIND HD 6-32 X 1/4 LG ATT PT	2	
- 19	735376	• CAPACITOR ASSEMBLY	2	
- 20	507575	• RESISTOR ASM	2	
- 21	367115	• JUMPER-TERMINAL STRIP VDC DISTR BRS	1	
- 22	320606	• TERMINAL BOARD- 7 DBL SCREW TERMINALS	1	
- 23	38353	• SCREW, MACH-FIL H 6-32 X 7/16 LG ATT PT	4	
- 24	2101389	• MARKER STRIP- 7 POS NOS. 1 THRU 7	1	
- 25	511553	• GROMMET, RUB-FOR 1 HOLE X 1/8 PNL	2	
- 26	144424	• SCREW	1	
- 27	55901	• WASHER, LOCK-EXT TEETH NO. 8 X 0.381 OD	1	
- 28	45690	• WASHER, FL - NO.10 X 7/16 OD X 1/32 THK	1	
- 29	34512	• SCREW, BIND HD 8-32 X .375 LG	1	
- 30	55901	• WASHER, LOCK-EXT TEETH NO. 8 X 0.381 OD	1	
- 31	532393	• CLAMP, CABLE	2	
- 32	10170	• SCREW, MACH-BIND HD 6-32 X 1/4 LG ATT PT	2	
- 33	56722	• WASHER, LOCK-EXT TEETH NO. 6 ATT PT	2	
- 37	825303	• CLAMP, CABLE	6	
- 38	128455	• SWITCH-TOGGLE	1	
- 39	553380	• SWITCH, PUSH-DPDT	2	
- 40	189138	• KNOB-SWITCH BLACK	2	
- 41	215680	• SWITCH, PUSH-NC 125V AC 1 AMP	2	
- 42	5376713	• INDICATOR ASSEMBLY, 24V-RED	10	
- 43	5376712	• INDICATOR ASSEMBLY, 24V-WHITE	1	
- 44	5353888	• HOUSING	11	
- 45	365048	• SWITCH, SENSITIVE SPDT	20	
- 46	2111232	• SEMICONDUCTOR DEVICE, DIODE-TYPE AM	27	
- 47	5318968	• RELAY, ARM-COIL 24V CONT 30V 5 AMP 4PDT	13	
- 48	5351156	• RELAY, ARM-COIL 24V CONT 30V 5 AMP 6PDT	6	
- 49	5214702	• RELAY- 4PDT, 2 AMP, 12V DC	2	
- 50	5276325	• RELAY, ENCLOSED, 18VDC	2	
- 51	5271294	• RELAY, ARMATURE- 6V DC ENCLOSED	1	
- 52	5318969	• RELAY, ARM-COIL 6V CONT 30V 5 AMP 4PDT	1	
- 53	5351139	• SOCKET, RELAY- 6 POSITION	9	
- 54	5318967	• SOCKET, 4 POSITION RELAY	16	
- 55	236550	• SCREW, MACH-BIND HD 4-40 X 0.375 LG ATT PT	25	
- 56	5351163	• RETAINER, RELAY- 6 POSITION	9	
- 57	5318966	• RETAINER, RELAY- 4 POSITION	16	
- 58	347820	• DIODE ASSEMBLY	AR	
- 59	2123789	• RESISTOR ASM	2	
- 60	205331	• JUMPER- 0.125 BRASS	5	
- 61	187243	• TERMINAL, SMALL TAPER	38	
- 62	324999	• TERMINAL BOARD- 109 FEEDTHRU TERMINALS	7	
- 63	236550	• SCREW, MACH-BIND HD 4-40 X 0.375 LG ATT PT	28	
- 64	284424	• CLIP-RELAY MOULDING BOTTOM MOUNTING	14	
- 65	2111232	• SEMICONDUCTOR DEVICE, DIODE-TYPE AM	1	
- 66	5327723	• RELAY, ARMATURE-DPDT TIME DELAY	1	
- 67	38235	• SCREW, MACH-BIND HD 6-32 X 0.312 LG ATT PT	2	
- 68	56722	• WASHER, LOCK-EXT TEETH NO. 6 ATT PT	2	
- 69	257986	• WASHER, FLAT NO. 6 ATT PT	2	

LIST 38. RELAY GATE HOUSING ASSEMBLY

FIGURE- INDEX NUMBER	PART NUMBER	DESCRIPTION	UNITS PER ASM.	USABLE ON CODE
38 - 70	5383345	• UNDERVOLTAGE PROTECTION ASM	1	
- 71	322551	• SCREW, MACH-BIND HD 6-32X3/4 LG ATT PT	2	
- 72	317009	• RESISTOR, FXD 390 OHM P/M 5 PCT 0.5W	3	
- 73	209002	• SEMICONDUCTOR DEVICE, DIODE	1	
- 74	369652	• TRANSISTOR-PNP	1	
- 75	476744	• TERMINAL	1	
- 76	483115	• POTENTIOMETER-250 OHMS P/M 5% 1W	1	
- 77	2111232	• SEMICONDUCTOR DEVICE, DIODE-TYPE AM	2	
- 78	5361892	• SOCKET	AR	
- 80	5383344	• BOARD ASSEMBLY	1	
- 81	5361886	• SPACER	2	
- 82	5276249	• DELAY ASSEMBLY, TIME, 5 SECONDS	1	
- 83	236550	• SCREW, MACH-BIND HD 4-40 X 0.375 LG ATT PT	2	
- 84	257985	• WASHER, FLAT-NO. 4 X 0.250 OD X 0.028 THK ATT PT	2	
- 85	338169	• WASHER, LOCK-EXT TEETH NO. 4 X .260 OD ATT PT	2	
- 86	37913	• NUT-HEX 4-40 X .250 ID ATT PT	2	
- 87	5351163	• RETAINER, RELAY- 6 POSITION	1	
- 88	5351156	• RELAY, ARM-COIL 24V CONT 30V 5 AMP 6PDT	1	
- 89	5351139	• SOCKET, RELAY- 6 POSITION	1	
- 90	438550	• SCREW, MACH-BIND HD 4-40 X 1/2 LG ATT PT	1	
- 91	2111232	• SEMICONDUCTOR DEVICE, DIODE-TYPE AM	2	
- 92	222098	• CAPACITOR, FIXED, TANTALUM-100 UF 10V	1	
- 93	597977	• DIODE, SEMICONDUCTOR- 700 OHMS 8.8V TV DI	1	
- 94	216452	• RESISTOR, FXD CARB, 2K OHM, 1/4W, 5%	1	
- 95	216492	• RESISTOR, FIXED-COMP 110K P/M 5% 1/4W	1	
- 96	217082	• RESISTOR, FXD, COMP- 820 OHMS P/M 5% 1/4W	1	
- 97	369652	• TRANSISTOR-PNP	1	
- 98	369654	• TRANSISTOR-NPN	1	
- 99	5276250	• BOARD ASM	1	
- 100	5213729	• RELAY, TIME DELAY-VAR 0.6 TO 60 SEC 24VDC	2	
- 101	213507	• SOCKET, ELECTRON TUBE-OCTAL	2	
- 102	10170	• SCREW, MACH-BIND HD 6-32 X 1/4 LG ATT PT	4	
- 103	123073	• GROMMET, RUBBER	1	
- 104	5722081	• HANDLE, RELAY GATE	1	
- 105	81693	• SCREW, MACH-BIND HD 6-32 X 3/8 LG ATT PT	2	
- 106	312575	• RING, RETAINING- 0.4375 ID X 0.040 THK	1	
- 107	124436	• STUD, TURNLOCK FASTENER	1	
- 108	312573	• EYELET, TURNLOCK FASTENER- 0.354 ID	1	
- 108A	2102364	• CLAMP, LOOP- 0.220 ID 0.170 DIA MTG HOLE	2	
- 108B	10295	• SCREW, MACH-BIND HD 10-32 X 1.125 LG ATT PT	1	
- 108C	32042	• SCREW, MACH BIND. HD 10-32 X 3/8 LG. ATT PT	1	
- 108D	45690	• WASHER, FL - NO.10 X 7/16 OD X 1/32 THK ATT PT	1	
- 108E	11598	• NUT, PLAIN-HEX 10-32 X 3/8 FL W ATT PT	1	
- 109	5236967	• JUMPER ASM-GRN/YEL 6 IN. 10AWG 1 LUG EA FOR COMPONENT PARTS SEE FIG. 59-34A	1	
- 110	5677	• SCREW, MACH-BIND HD 10-32 X 3/4 LG ATT PT	1	
- 111	56079	• WASHER, LOCK-EXT 1 .195 ID .410 OD ATT PT	1	
- 112	5722119	• HINGE, RELAY GATE	1	
- 113	99	• SCREW, MACH-FL CSK HD 10-32 X 3/8 LG ATT PT	2	
- 114	367	• SCREW, MACH-FL CSK HD 10-32 X 5/8 LG ATT PT	2	
- 115	5781466	• FRAME-RELAY GATE	1	
- 116	5677	• SCREW, MACH-BIND HD 10-32 X 3/4 LG ATT PT	6	
- 117	56079	• WASHER, LOCK-EXT 1 .195 ID .410 OD ATT PT	6	
- 118	5781467	• HOUSING-RELAY GATE	1	

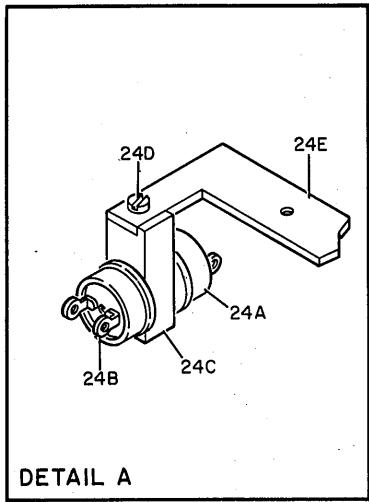

FOR PARTS
NOT SHOWN
SEE FIG. 37

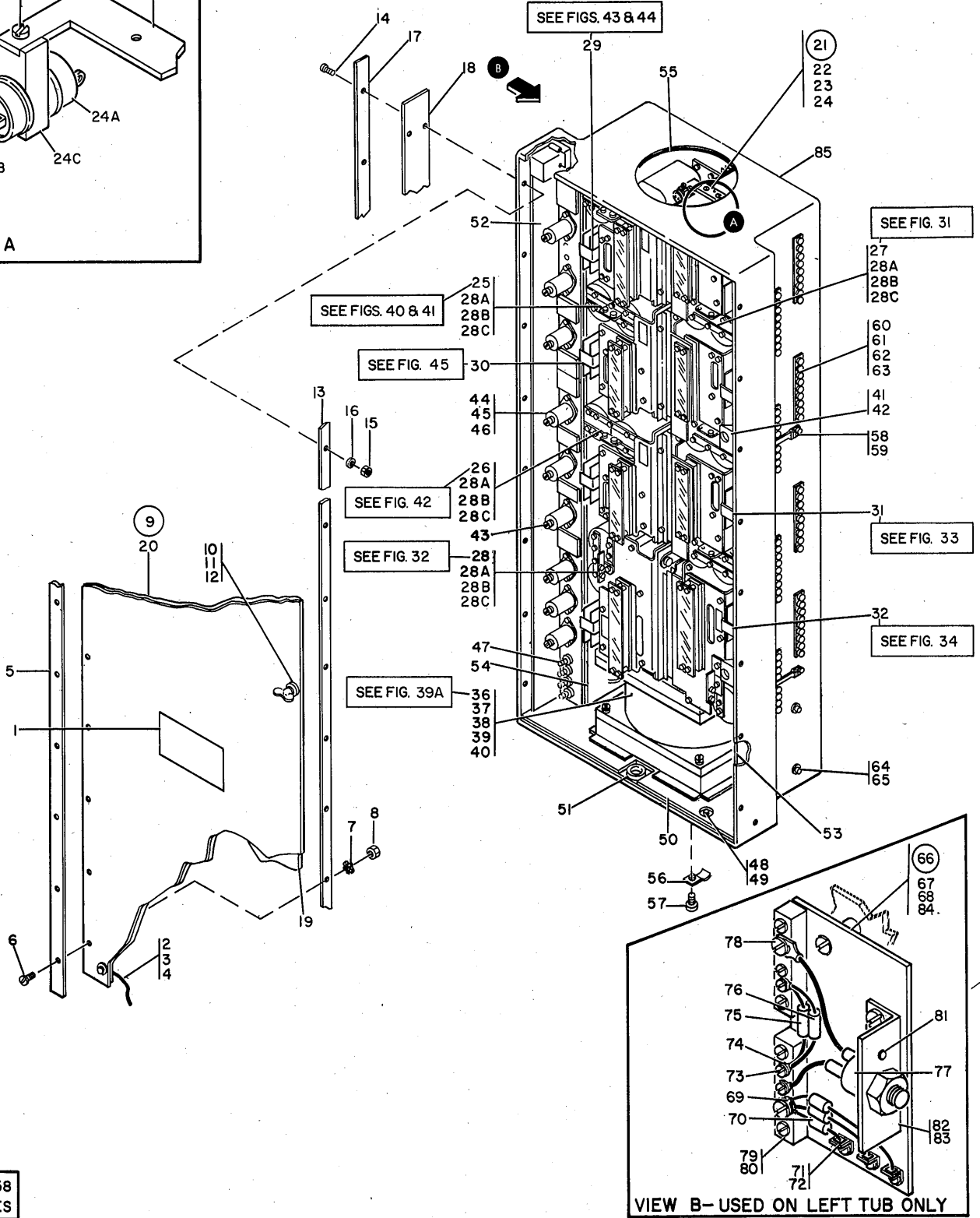

SEE LIST 58
FOR CABLES

FIGURE 39. RIGHT AND LEFT POWER TUB ASSEMBLY.

LIST 39. RIGHT AND LEFT POWER TUB ASSEMBLY

FIGURE- INDEX NUMBER	PART NUMBER	DESCRIPTION	UNITS PER ASM.	USABLE ON CODE
39 -		CODE A USED ON RIGHT POWER TUB ONLY CODE B USED ON LEFT POWER TUB ONLY		
-	5781316	POWER TUB ASSEMBLY LEFT	REF	B
-	5781317	POWER TUB ASSEMBLY RIGHT	REF	A
		FOR NEXT HIGHER ASM, SEE FIGURE 37-32 AND 37-33		
- 1	369207	. LABEL, VOLTAGE	1	
- 2	5238967	. JUMPER ASM-GRN/YEL 6 IN. 10AWG 1 LUG EA FOR COMPONENT PARTS SEE FIG. 59-34A	1	
- 3	32042	. SCREW, MACH BIND. HD 10-32 X 3/8 LG. ATT PT	2	
- 4	56079	. WASHER, LOCK-EXT T .195 ID .410 OD ATT PT	2	
- 5	5722113	. RETAINER, STRIP, ENCLOSURE DOOR	1	
- 6	25627	. SCREW-BD. HD 8-32 X .500 LG ATT PT	8	
- 7	55901	. WASHER, LOCK-EXT TEETH NO. 8 X 0.381 OD ATT PT	8	
- 8	257189	. NUT, HEX- 8-32 ATT PT	8	
- 9	5722106	. DOOR ASSEMBLY, SUPPLY ENCLOSURE	1	
- 10	124436	. . STUD, TURNLOCK FASTENER	2	
- 11	312575	. . RING, RETAINING- 0.4375 ID X 0.040 THK	2	
- 12	312573	. . EYELET, TURNLOCK FASTENER- 0.354 ID	2	
- 13	5276322	. . HINGE, POWER ENCLOSURE	1	
- 14	25627	. . SCREW-BD. HD 8-32 X .500 LG ATT PT	8	
- 15	257189	. . NUT, HEX- 8-32 ATT PT	8	
- 16	55901	. . WASHER, LOCK-EXT TEETH NO. 8 X 0.381 OD ATT PT	8	
- 17	5722113	. . RETAINER, STRIP, ENCLOSURE DOOR	1	
- 18	5722112	. . GASKET, ENCLOSURE DOOR	1	
- 19	5722108	. . LINER, SUPPLY DOOR	1	
- 20	5722107	. . DOOR, POWER SUPPLY ENCLOSURE	1	
- 21	5781486	. SWITCH ASSEMBLY-THERMAL	1	
- 22	338238	. SCREW, MACH-BD HD 4-40 NC X .3125 LG ATT PT	2	
- 23	257985	. WASHER, FLAT-NO. 4 X 0.250 OD X 0.028 THK ATT PT	2	
- 24	257984	. WASHER, LOCK-SPLIT 1/8 ID X 13/64 OD ATT PT	2	
- 24A	5319910	. . THERMOSTAT	1	
- 24B	5403116	. . SWITCH	1	
- 24C	5357072	. . SWITCH	1	
- 24D	10170	. . SCREW, MACH-BIND HD 6-32 X 1/4 LG ATT PT	1	
- 24E	5781487	. . BRACKET	1	
- 25	5708903	. REMOTE O/V - O/C TERMINAL BOARD	1	B
- 25	5708908	FOR DETAIL BREAKDOWN SEE FIGURE 40 . REMOTE O/V-O/C ASSEMBLY		A
- 26	5708932	FOR DETAIL BREAKDOWN SEE FIGURE 41 . REMOTE O/V-O/C ASSEMBLY	1	A
- 27	5708902	FOR DETAIL BREAKDOWN SEE FIGURE 42 . REMOTE O/V - O/C TERMINAL BOARD	5	B
- 27	5708902	FOR DETAIL BREAKDOWN SEE FIGURE 31 . REMOTE O/V - O/C TERMINAL BOARD	4	A
- 28	5709004	FOR DETAIL BREAKDOWN SEE FIGURE 31 . REMOTE O/V-O/C ASSEMBLY	2	
- 28A	24752	. SCREW, MACH-FIL H 8-32 X 5/16 LG ATT PT	AR	
- 28B	22478	. WASHER, FL- 0.170 ID 0.375 OD 0.32 THK ATT PT	AR	
- 28C	60646	. WASHER, LOCK-INT T NO. 8 ATT PT	AR	
- 29	5712080	. 48V AT 2 AMP MAGNETIC AMPLIFIER ASSEMBLY	1	A
- 29	5712030	FOR DETAIL BREAKDOWN SEE FIGURE 43 . 6V AT 25 AMP MAGNETIC AMPLIFIER ASSEMBLY	1	B
- 30	5709320	FOR DETAIL BREAKDOWN SEE FIGURE 44 . 18 VDC AT 11 AMPS POWER SUPPLY ASSEMBLY	1	A
- 31	5712020	FOR DETAIL BREAKDOWN SEE FIGURE 45 . 3V AT 40 AMP MAGNETIC AMPLIFIER ASSEMBLY	5	B
- 31	5712020	FOR DETAIL BREAKDOWN SEE FIGURE 33 . 3V AT 40 AMP MAGNETIC AMPLIFIER ASSEMBLY	4	A
- 32	5712040	FOR DETAIL BREAKDOWN SEE FIGURE 33 . 6V AT 40 AMP MAGNETIC AMPLIFIER ASSEMBLY	2	
- 36	5781518	FOR DETAIL BREAKDOWN SEE FIGURE 34 . FAN ASSEMBLY	1	
- 37	32617	FOR DETAIL BREAKDOWN SEE FIGURE 39A . SCREW, MACH-BIND HD 10-32 X 0.438 LG ATT PT	2	
- 38	9092	. WASHER-LOCK, SPLIT RING, .194 ID .3370D ATT PT	2	
- 39	45690	. WASHER, FL - NO.10 X 7/16 OD X 1/32 THK ATT PT	2	
- 40	56079	. WASHER, LOCK-EXT T .195 ID .410 OD ATT PT	2	
- 41	528138	. RECEPTACLE, TURNLOCK FASTENER	2	
- 42	10170	. SCREW, MACH-BIND HD 6-32 X 1/4 LG ATT PT	4	
- 43	236849	. SCREW, MACH-BIND HD 10-32 X 0.250 LG	AR	B

LIST 39. RIGHT AND LEFT POWER TUB ASSEMBLY

FIGURE- INDEX NUMBER	PART NUMBER	DESCRIPTION	UNITS PER ASM.	USABLE ON CODE
39 - 44	5364225	. CAPACITOR, FIXED, MYLAR-0.5 UF 100V	18	B
- 44	5364225	. CAPACITOR, FIXED, MYLAR-0.5 UF 100V	16	A
- 45	10170	. SCREW, MACH-BIND HD 6-32 X 1/4 LG ATT PT	AR	B
- 46	56722	. WASHER, LOCK-EXT TEETH NO. 6 ATT PT	AR	B
- 47	504189	. TERMINAL, INSULATED-FEED THRU	12	B
- 47	504189	. TERMINAL, INSULATED-FEED THRU	16	A
- 48	731629	. SCREW, SELF TAPPING- 10-32 X 3/8 LG	1	
- 49	56079	. WASHER, LOCK-EXT T .195 ID .410 OD	1	
- 50	5722111	. LINER, BOTTOM, ENCLOSURE	AR	
- 51	338327	. GROMMET, RUB-FOR 1-1/4 HOLE X 1/16 PNL	1	
- 52	5722114	. LINER, ENCLOSURE	AR	
- 53	5722115	. LINER, ENCLOSURE	AR	
- 54	5722109	. LINER, ENCLOSURE	AR	
- 55	5722110	. LINER, TOP, ENCLOSURE	AR	
- 56	15889	. CLAMP-CABLE	1	
- 57	58207	. SCREW, MACH-UNDRCT BIND HD 8-32 X 1/4 LG ATT PT	1	
- 58	532393	. CLAMP-ADJUSTABLE CABLE	4	
- 59	28413	. SCREW, MACH-BIND HD 10-32 X 5/16 LG ATT PT	4	
- 60	5276362	. BUS BAR, VOLTAGE	16	B
- 60	5276362	. BUS BAR, VOLTAGE	14	A
- 61	58207	. SCREW, MACH-UNDRCT BIND HD 8-32 X 1/4 LG	AR	B
- 62	5276363	. INSULATOR	16	B
- 62	5276363	. INSULATOR	14	A
- 63	34512	. SCREW, BIND, HD 8-32 X .375 LG	AR	B
- 64	32042	. SCREW, MACH BIND. HD 10-32 X 3/8 LG.	1	
- 65	56079	. WASHER, LOCK-EXT T .195 ID .410 OD	1	
- 66	5782275	. O/V/DC ASSEMBLY	1	B
- 67	438587	. SCREW, MACH-BIND HD 8-32 X 1-1/8 LG ATT PT	2	
- 68	5782293	. SPACER ATT PT	2	
- 69	313289	. . TERMINAL, LUG-NONINS 20AWG NO.10 MTG HOLE	3	
- 70	491320	. . CAPACITOR, FILM, .1MF 5% 100 VOLTS	3	
- 71	2102182	. . TERMINAL, FIXED	3	
- 72	251970	. . SCREW-MACH BD. HD. 4-40 X 1/4 LG ATT PT	3	
- 73	81693	. . SCREW, MACH-BIND HD 6-32 X 3/8 LG	4	
- 74	186962	. . TERMINAL-RING, 24-20 AWG #6 HOLE, NON INS	4	
- 75	213693	. . RESISTOR, FXD, COMP- 1K P/M 5% 1/2W	1	
- 76	491228	. . CAPACITOR, FXD, FILM- 0.01MF P/M 10% 100V	1	
- 77	5261457	. . SEMICONDUCTOR DEVICE-CONTROLLED RECT	1	
- 78	32042	. . SCREW, MACH BIND. HD 10-32 X 3/8 LG. ATT PT	2	
- 79	5493952	. . BUS BAR	2	
- 80	5528	. . SCREW, MACH BIND HD 8-32 X .625 LG ATT PT	4	
- 81	236849	. . SCREW, MACH-BIND HD 10-32 X 0.250 LG	1	
- 82	5493953	. . BRACKET	1	
- 83	34512	. . SCREW, BIND, HD 8-32 X .375 LG ATT PT	2	
- 84	5782276	. . BOARD	1	
- 85	5722143	. TUB ASSEMBLY, POWER, LEFT	1	B
- 85	5722144	. TUB ASSEMBLY, POWER, RIGHT	1	A

FOR PARTS
NOT SHOWN
SEE FIG. 39

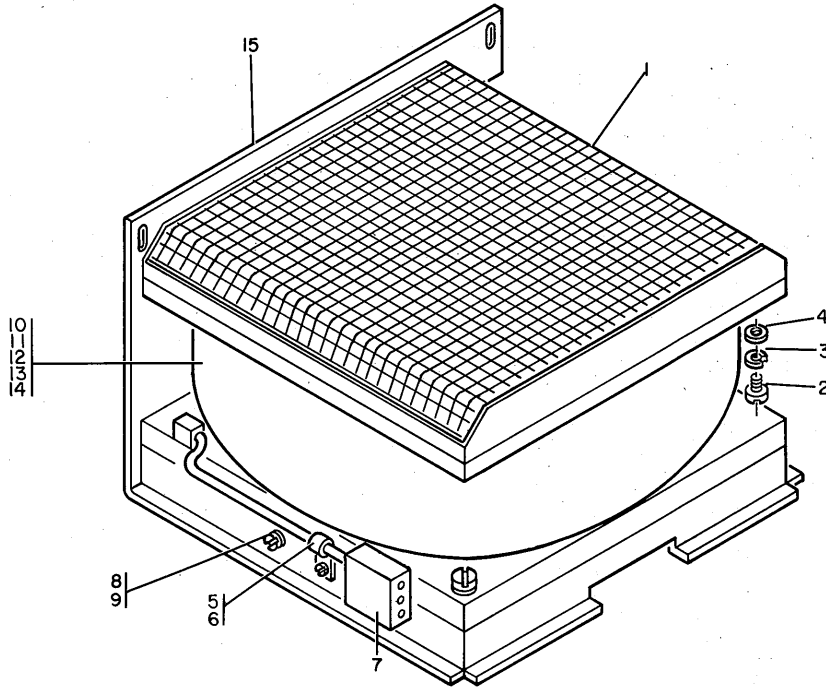

FIGURE 39A. FAN ASSEMBLY.

LIST 39A. FAN ASSEMBLY

FIGURE- INDEX NUMBER	PART NUMBER	DESCRIPTION	UNITS	USABLE ON CODE
			PER ASM.	
39A-	5781518	FAN ASSEMBLY FOR NEXT HIGHER ASM, SEE FIG. 39-36	REF	
- 1	5781517	. GUARD	1	
- 2	55918	. SCREW, MACH-BIND HD 10-32 X 5/8 LG	ATT PT	2
- 3	9092	. WASHER-LOCK, SPLIT RING, .194 ID .337OD	ATT PT	2
- 4	45690	. WASHER, FL - NO.10 X 7/16 OD X 1/32 THK	ATT PT	2
- 5	356742	. CLAMP, LOOP- C.250 ID C.177 DIA MTG HOLE		1
- 6	221790	. SCREW, MACH-BIND HD 8-32 X 3/16 LG	ATT PT	1
- 7	5781519	. JUMPER ASM		1
- 8	221790	. SCREW, MACH-BIND HD 8-32 X 3/16 LG	ATT PT	1
- 9	55901	. WASHER, LOCK-EXT TEETH NO. 8 X 0.381 OD	ATT PT	1
- 10	5150035	. FAN		1
- 11	507796	. SCREW, MACH-BIND HD 10-32 X 1 LG	ATT PT	4
- 12	45690	. WASHER, FL - NO.10 X 7/16 OD X 1/32 THK	ATT PT	4
- 13	9092	. WASHER-LOCK, SPLIT RING, .194 ID .337OD	ATT PT	4
- 14	11598	. NUT, PLAIN-HEX 10-32 X 3/8 FL W	ATT PT	4
- 15	5781512	. SUPPORT		1

FOR PARTS
NOT SHOWN
SEE FIG. 39

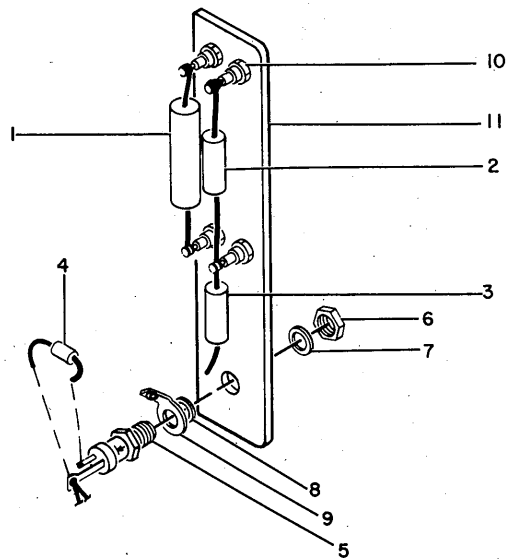

FIGURE 40. REMOTE O/V-O/C TERMINAL BOARD ASSEMBLY.

LIST 40. REMOTE O/V-O/C TERMINAL BOARD ASSEMBLY

FIGURE- INDEX NUMBER	PART NUMBER	DESCRIPTION				UNITS PER ASM.	USABLE ON CODE
		1	2	3	4		
40 -	5708903	REMOTE O/V - O/C TERMINAL BOARD FOR NEXT HIGHER ASM, SEE FIG. 39-25				REF	
- 1	207324	. RESISTOR,FXD,WW- 0.1 OHM P/M 5% 5W				1	
- 2	481484	. RESISTOR				1	
- 3	481921	. RESISTOR,PRECISION 115 OHMS				1	
- 4	491228	. CAPACITOR,FXD,FILM- 0.01MF P/M 10% 100V				1	
- 5	595256	. SEMICONDUCTOR DEVICE,D10- 5V 2 AMP				1	
- 6	160017	. NUT,PLAIN,HEX- 1/4-28 X 7/16 FL W				1	ATT PT
- 7	65756	. WASHER,LOCK-INT TEETH 0.267 ID X 0.478OD				1	ATT PT
- 8	3550	. WASHER,FL- 1/4 X 9/16 OD X 0.050 THK				1	ATT PT
- 9	322765	. TERMINAL,LUG				1	
- 10	5261459	. TERMINAL,STANDOFF				4	
- 11	5708927	. BRACKET, MOUNTING, REMOTE O/V-O/C				1	

FOR PARTS
NOT SHOWN
SEE FIG. 39

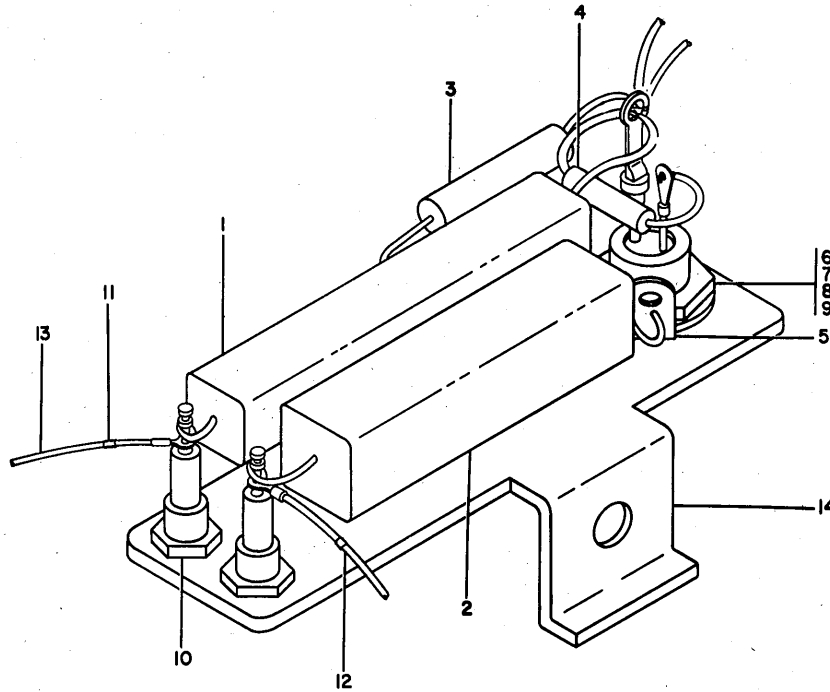

FIGURE 41. REMOTE O/V-O/C ASSEMBLY.

LIST 41. REMOTE O/V-O/C ASSEMBLY

FIGURE- INDEX NUMBER	PART NUMBER	DESCRIPTION				UNITS PER ASM.	USABLE ON CODE
		1	2	3	4		
41 -	5708908	REMOTE O/V-O/C ASSEMBLY				REF	
- 1	5213466	FOR NEXT HIGHER ASM, SEE FIG. 39-25				1	
- 2	472250	• RESISTOR, FXD, FILM- 1430 OHMS 1PCT 2W				1	
- 3	481914	• RESISTOR, FXD, FILM- 95.3 OHMS 1PCT 1/2W				1	
- 4	491228	• CAPACITOR, FXD, FILM- 0.01MF P/M 10% 100V				1	
- 5	322765	• TERMINAL, LUG				1	
- 6	595256	• SEMICONDUCTOR DEVICE, D10- 5V 2 AMP				1	
- 7	160017	• NUT, PLAIN, HEX- 1/4-28 X 7/16 FL W				1	
- 8	65756	• WASHER, LOCK-INI TEETH 0.267 ID X 0.4780D				1	ATT PT
- 9	3550	• WASHER, FL- 1/4 X 9/16 OD X 0.050 THK				1	ATT PT
- 10	5261459	• TERMINAL, STANDOFF				3	
- 11	350564	• LABEL-SYMBOLS PLUS AND MINUS				3	
- 12	5709465	• LABEL-STRIP SELF ADHESIVE				3	
- 13	5759995	• JUMPER ASSEMBLY- 20 AWG 1 TERMINAL				3	
- 13	5760027	FOR COMPONENT PARTS SEE FIG. 59-43				1	
- 13	5760047	• JUMPER ASSEMBLY- 10 AWG 1 TERMINAL				1	
- 13	5760071	FOR COMPONENT PARTS SEE FIG. 59-34				1	
- 13	5760071	• JUMPER ASSEMBLY- 20 AWG 1 TERMINAL				1	
- 13	5760071	FOR COMPONENT PARTS SEE FIG. 59-36C				1	
- 14	5708928	• JUMPER ASSEMBLY				1	
- 14	5708928	FOR COMPONENT PARTS SEE FIG. 59-36C				1	
- 14	5708928	• BRACKET				1	

FOR PARTS
NOT SHOWN
SEE FIG. 39

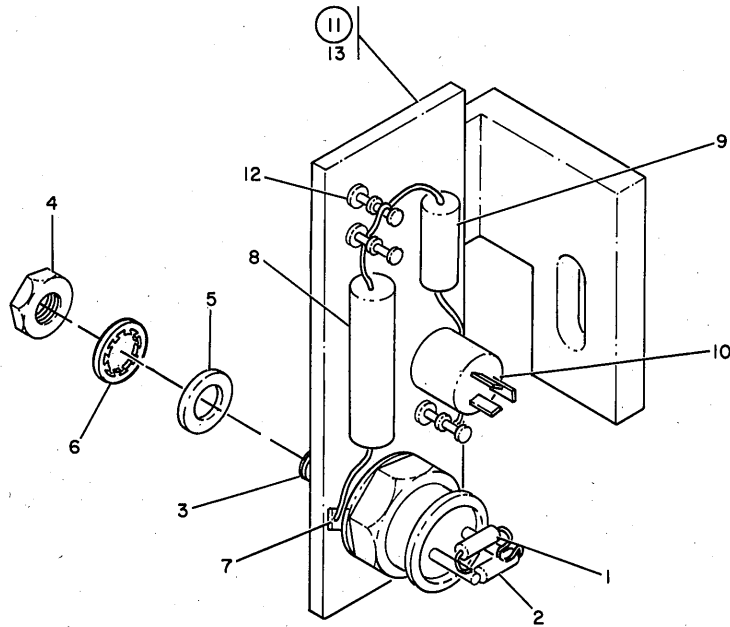

FIGURE 42. REMOTE O/V-O/C ASSEMBLY.

LIST 42. REMOTE O/V-O/C ASSEMBLY

FIGURE- INDEX NUMBER	PART NUMBER	DESCRIPTION				UNITS PER ASM.	USABLE ON CODE
		1	2	3	4		
42 -	5708932	REMOTE O/V-O/C ASSEMBLY				REF	
- 1	491228	FOR NEXT HIGHER ASM, SEE FIGURE 39-26				1	
- 2	213693	• CAPACITOR,FXD,FILM- 0.01MF P/M 10% 100V				1	
- 3	5214335	• RESISTOR,FXD,COMP- 1K P/M 5% 1/2W				1	
- 4	160017	• SEMICONDUCTOR,CONTROLLED RECTIFIER				1	
- 5	3550	• NUT,PLAIN,HEX- 1/4-28 X 7/16 FL W				1	
- 6	65756	• WASHER,FL- 1/4 X 9/16 UD X 0.050 THK				1	
- 7	322765	• WASHER,LOCK-INT TEETH 0.267 ID X 0.4780D				1	
- 8	208226	• TERMINAL,LUG				1	
- 9	502475	• RESISTOR,FXD,WH 0.3 OHMS P/M 5% 1/2W				1	
- 10	207340	• RESISTOR				1	
- 11	2572853	• RESISTOR,VAR- 250 OHMS P/M 10% 1/2W				1	
- 12	337545	• BOARD ASM				1	
- 13	2572849	• LUG,TERMINAL				3	
		• COMPONENT BOARD				1	

FOR PARTS
NOT SHOWN
SEE FIG. 39

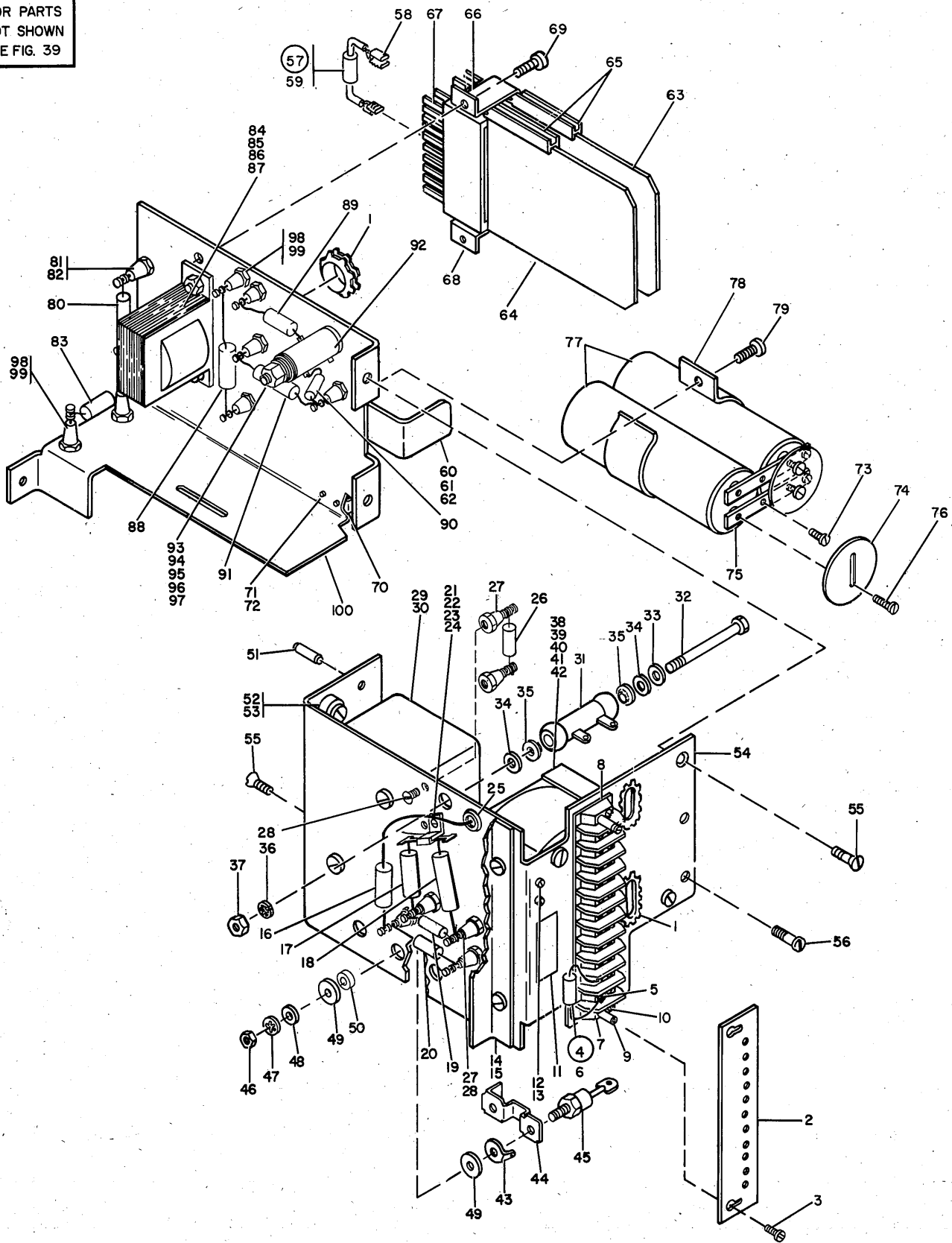

FIGURE 43. 48 VOLT AT 2 AMP MAGNETIC AMPLIFIER ASSEMBLY.

LIST 43. 48 VOLT AT 2 AMP MAGNETIC AMPLIFIER ASSEMBLY

FIGURE- INDEX NUMBER	PART NUMBER	DESCRIPTION	UNITS PER ASM.	USABLE ON CODE
		1 2 3 4		
43 -	5712080	48V AT 2 AMP MAGNETIC AMPLIFIER ASSEMBLY FOR NEXT HIGHER ASM, SEE FIGURE 39-29	REF	
- 1	730432	. GROMMET, CATERPILLAR	AR	
- 2	5762547	. SHIELD, TERMINAL BOARD- 11 POS	1	
- 3	10170	. SCREW, MACH-BIND HD 6-32 X 1/4 LG	2	ATT PT
- 4	5708939	. CAPACITOR ASM- 0.100MFD P/M 10% 100VDC	1	
- 5	334921	. . TERMINAL-RING, 18-22 AWG, #6 HOLE, INS	2	
- 6	217077	. . CAPACITOR, FXD-POLY- .1MFD P/M 10% 100VDC	1	
- 7	80352	. TERMINAL BOARD	1	
- 8	341492	. MARKER, TERMINAL	1	
- 9	210883	. STUD-SHIELD MTG, TAPPED, NO. 6-32	2	ATT PT
- 10	35739	. SCREW, MACH-BIND HD 6-32 X 15/16 LG	2	ATT PT
- 11	5261412	. LABEL	1	
- 12	55726	. SCREW, MACH-BIND HD 6-32 X .188 LG	1	
- 13	56722	. WASHER, LOCK-EXT TEETH NO. 6	1	
- 14	5261286	. BRACKET	1	
- 15	55726	. SCREW, MACH-BIND HD 6-32 X .188 LG	2	ATT PT
- 16	491221	. RESISTOR-FIXED-COMP 39 OHM P/M 5PCT 1/2W	1	
- 17	317019	. RESISTOR, FXD, COMP- 2000 OHMS P/M 5% 1/2W	1	
- 18	492570	. CAPACITOR, TANTALUM-220 UUF P/M 20% 10VDC	1	
- 19	2111232	. SEMICONDUCTOR DEVICE, DIODE-TYPE AM	1	
- 20	483030	. CAPACITOR, FXD, ELECT-20 MFD 15 VDCW	1	
- 21	478045	. TERMINAL, SOLDER	1	
- 22	81693	. SCREW, MACH-BIND HD 6-32 X 3/8 LG	1	ATT PT
- 23	62031	. WASHER, LOCK-INT TEETH NO. 6 X 0.295 OD	1	ATT PT
- 24	257187	. NUT, PLAIN, HEX- 6-32 X 3/8 FL W	1	ATT PT
- 25	220690	. GROMMET, RUB-FOR 3/8 HOLE X 1/16 PNL	1	
- 26	326367	. CAPACITOR, FXD, PAPER- 0.1 UF P/M 10% 400V	1	
- 27	533534	. TERMINAL	6	
- 28	10170	. SCREW, MACH-BIND HD 6-32 X 1/4 LG	6	ATT PT
- 29	5261288	. REACTOR, SATURABLE	1	
- 30	186759	. SCREW, MACH-BIND HD 8-32 X 5/16 LG	2	ATT PT
- 31	2102582	. RESISTOR, FXD, WW- 250 OHMS P/M 5% 25W	1	
- 32	438593	. SCREW, MACH-BIND HD NO. 8-32 X 2 1/2 LG	1	ATT PT
- 33	22478	. WASHER, FL- 0.170 ID 0.375 OD 0.32 THK	1	ATT PT
- 34	442958	. INSULATOR, WASH- 7/16 ID 3/4 OD 1/32 THK	2	ATT PT
- 35	507144	. WASHER-CENTERING 0.173 ID X 5/8 OD	2	ATT PT
- 36	60646	. WASHER, LOCK-INT T NO. 8	1	ATT PT
- 37	257189	. NUT, HEX- 8-32	1	ATT PT
- 38	5261283	. TRANSFORMER, POWER	1	
- 39	186758	. SCREW, MACH-BIND HD 8-32 X 0.438	3	ATT PT
- 40	38454	. SCREW, MACH-FL CSK HD 8-32 X 7/16 LG	1	ATT PT
- 41	55901	. WASHER, LOCK-EXT TEETH NO. 8 X 0.381 OD	4	ATT PT
- 42	257189	. NUT, HEX- 8-32	4	ATT PT
- 43	316996	. TERMINAL, LUG-NONINS 9AWG NO. 8 MTG HOLE	2	
- 44	478043	. JUMPER - PLATE	1	
- 45	5213400	. RECTIFIER, SILICON	4	
- 46	11891	. NUT-PLAIN, HEX, 10-32 X 3/8 FL W BRS	4	ATT PT
- 47	56121	. WASHER, LOCK-INT TEETH NO. 10 X 0.381 OD	4	ATT PT
- 48	45690	. WASHER, FL - NO.10 X 7/16 OD X 1/32 THK	4	ATT PT
- 49	217019	. WASHER, INSULATING	8	ATT PT
- 50	473582	. INSULATOR	4	ATT PT
- 51	5261379	. PIN, STRAIGHT DOWEL	2	
- 52	5261314	. SCREW, CAPTIVE- 10-32 X 1/2 LG	2	
- 53	5261315	. ADAPTER-CAPTIVE SCREW	2	
- 54	5261266	. HOUSING	1	
- 55	38452	. SCREW, MACH-FL CSK HD 8-32 X 5/16 LG	2	ATT PT
- 56	186759	. SCREW, MACH-BIND HD 8-32 X 5/16 LG	1	ATT PT
- 57	5261789	. CAPACITOR ASSEMBLY, 0.022UF, PORM 10 PCT	2	
- 58	596255	. . TERMINAL, SLIP-ON	2	
- 59	507536	. . CAPACITOR, FXD, PAPER DIELECTRIC, 0.022UF	1	
- 60	5261316	. BRACKET, CARD RETAINING	1	
- 61	479714	. SCREW, SHLDR-FLAT HD 4-40 X 19/64 LG	1	ATT PT
- 62	5261354	. SCREW, MACH, CAPTIVE- 6-32 X 3/8 LG	1	ATT PT
- 63	372969	. CARD	1	
- 64	374772	. CARD ASM	1	
- 65	216207	. GUIDE-SINGLE CARD SHORT	2	
- 66	473547	. SPACER, 1 X 2 3/8 IN .12 IN THICK	1	
- 67	216076	. TERMINAL BLOCK AND CONTACT ASSEMBLY	2	
- 68	473530	. BRACKET	1	
- 69	55726	. SCREW, MACH-BIND HD 6-32 X .188 LG	2	ATT PT
- 70	5261317	. BRACKET	1	
- 71	10170	. SCREW, MACH-BIND HD 6-32 X 1/4 LG	2	ATT PT
- 72	56722	. WASHER, LOCK-EXT TEETH NO. 6	2	ATT PT

LIST 43. 48 VOLT AT 2 AMP MAGNETIC AMPLIFIER ASSEMBLY

FIGURE- INDEX NUMBER	PART NUMBER	DESCRIPTION	UNITS PER ASM.	USABLE ON CODE
		1 2 3 4		
43 - 73	221790	. SCREW, MACH-BIND HD 8-32 X 3/16 LG	4	
- 74	5261296	. COVER-CAPACITOR	2	
- 75	5261306	. BUS BAR	2	
- 76	32042	. SCREW, MACH BIND. HD 10-32 X 3/8 LG.	4	ATT PT
- 77	5709383	. CAPACITOR, FIXED, ELECT-2500 UF 75 V	2	
- 78	5261276	. CLAMP	1	
- 79	321483	. SCREW, MACH-BIND HD 8-32 X 1 LG	1	ATT PT
- 80	335017	. RESISTOR, FIXED COMP 240 OHMS PM 5% 1W	1	
- 81	533534	. TERMINAL	2	
- 82	38442	. SCREW, MACH-FL CSK HD 6-32 X 1/4 LG	2	ATT PT
- 83	335328	. RESISTOR, FXD, COMP- 680 OHMS P/M 5% 2W	1	
- 84	5261289	. CHOKE, FILTER	1	
- 85	4636	. SCREW, MACH-FL CSK HD 8-32 X 3/8 LG	2	ATT PT
- 86	55901	. WASHER, LOCK-EXT TEETH NO. 8 X 0.381 OD	2	ATT PT
- 87	257189	. NUT, HEX- 8-32	2	ATT PT
- 88	501551	. RESISTOR, FIXED, WIREWOUND	1	
- 89	334949	. RESISTOR, FXD, COMP- 20 OHMS P/M 5% 1/2W	1	
- 90	217051	. CAPACITOR	1	
- 91	492448	. RESISTOR, FXD, FILM- 130 OHMS P/M 5% 2W	1	
- 92	437261	. RESISTOR, VARIABLE, WIREWOUND	1	
- 93	322555	. SCREW, MACH-RH 6-32 X 2-1/4 LG	1	ATT PT
- 94	442959	. INSULATOR, WASH- 11/64 ID 15/32 OD 1/32 T	2	ATT PT
- 95	257986	. WASHER, FLAT NO. 6	1	ATT PT
- 96	6364	. WASHER, LOCK-SPLIT NO. 6 X 1/4 OD	1	ATT PT
- 97	257187	. NUT, PLAIN, HEX- 6-32 X 3/8 FL W	1	ATT PT
- 98	533534	. TERMINAL	7	
- 99	10170	. SCREW, MACH-BIND HD 6-32 X 1/4 LG	7	ATT PT
-100	5261267	. PLATE-CAPACITOR	1	

FOR PARTS
NOT SHOWN
SEE FIG. 39

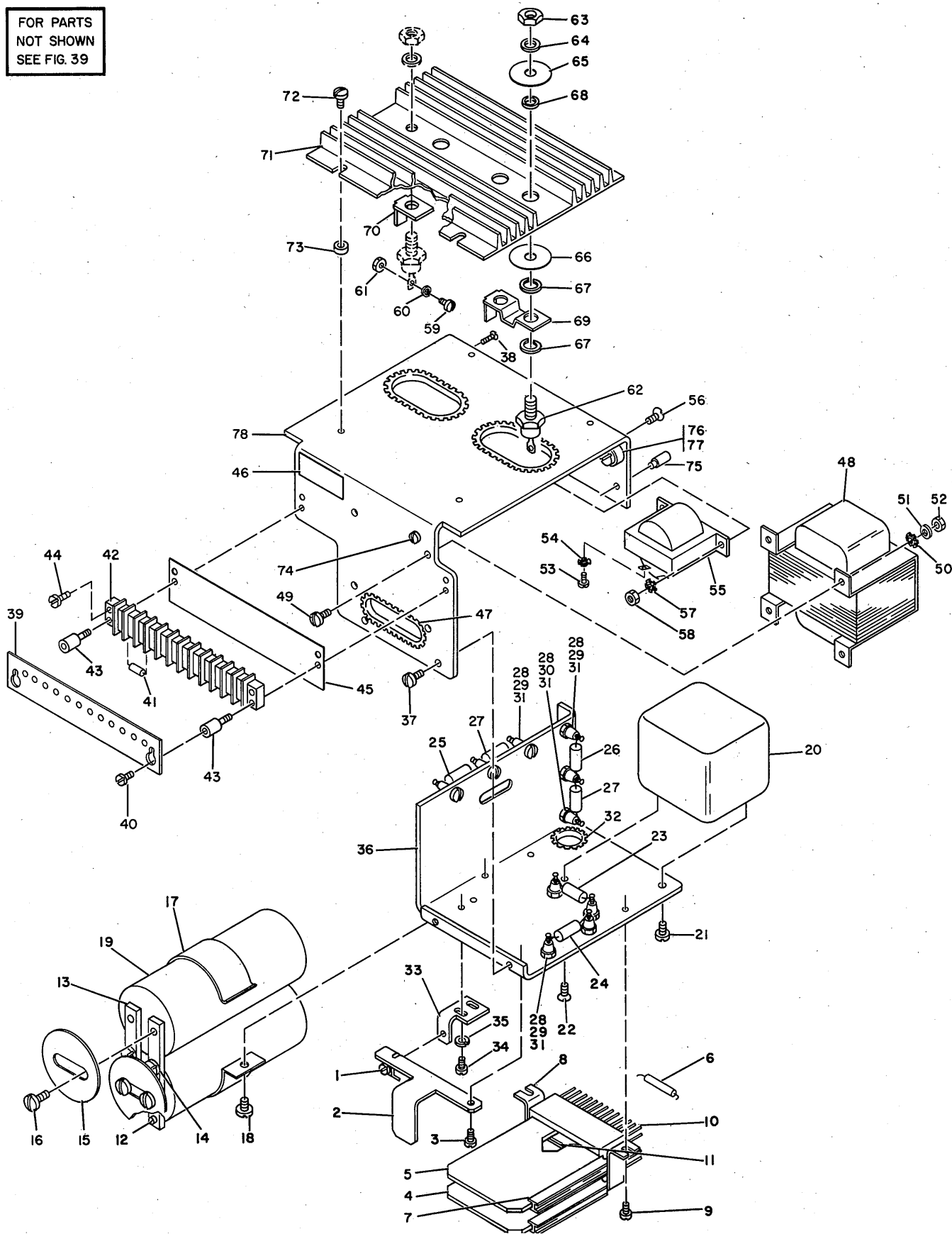

FIGURE 44. 6 VOLT AT 25 AMP MAGNETIC AMPLIFIER ASSEMBLY.

LIST 44. 6 VOLT AT 25 AMP MAGNETIC AMPLIFIER ASSEMBLY

FIGURE- INDEX NUMBER	PART NUMBER	DESCRIPTION	UNITS PER ASM.	USABLE ON CODE
44 -	5712030	6V AT 25 AMP MAGNETIC AMPLIFIER ASSEMBLY FOR NEXT HIGHER ASM, SEE FIGURE 39-29	REF	
- 1	5261354	. SCREW, MACH, CAPTIVE- 6-32 X 3/8 LG	1	
- 2	5261316	. BRACKET, CARD RETAINING	1	
- 3	479714	. SCREW, SHLDR-FLAT HD 4-40 X 19/64 LG	1	ATT PT
- 4	372966	. CARD	1	
- 5	374772	. CARD ASM	1	
- 6	5261789	. CAPACITOR ASSEMBLY, 0.022UF, PORM 10 PCT	1	
- 7	216207	. GUIDE-SINGLE CARD SHORT	2	
- 8	473530	. BRACKET	1	
- 9	55726	. SCREW, MACH-BIND HD 6-32 X .188 LG	2	ATT PT
- 10	216076	. TERMINAL BLOCK AND CONTACT ASSEMBLY	2	
- 11	473547	. SPACER, 1 X 2 3/8 IN .12 IN THICK	1	
- 12	32617	. SCREW, MACH-BIND HD 10-32 X 0.438 LG	2	
- 13	5261313	. BUS BAR	2	
- 14	32042	. SCREW, MACH BIND. HD 10-32 X 3/8 LG.	2	ATT PT
- 15	362206	. COVER, CAPACITOR	2	
- 16	236849	. SCREW, MACH-BIND HD 10-32 X 0.250 LG	4	ATT PT
- 17	5261239	. CLAMP	1	
- 18	5677	. SCREW, MACH-BIND HD 10-32 X 3/4 LG	1	ATT PT
- 19	5709382	. CAPACITOR, FXD, ELECTROLYTIC, 0.047 UF	2	
- 20	5261418	. REACTOR, SATURABLE	1	
- 21	58207	. SCREW, MACH-UNDRCT BIND HD 8-32 X 1/4 LG	1	ATT PT
- 22	38451	. SCREW, MACH-FL CSK HD 8-32 X 1/4 LG	1	ATT PT
- 23	481443	. RESISTOR, FXD, FILM- 34.8 OHMS P/M 1% 500W	1	
- 24	492448	. RESISTOR, FXD, FILM- 130 OHMS P/M 5% 2W	1	
- 25	317077	. RESISTOR, FXD COMP, 10 OHMS P/M 5 PCT 2W	2	
- 26	2102155	. RESISTOR, AXIAL POWER, 500 OHM 5% 5 WATT	1	
- 27	335017	. RESISTOR, FIXED COMP 240 OHMS PM 5% 1W	1	
- 28	533534	. TERMINAL	10	
- 29	10170	. SCREW, MACH-BIND HD 6-32 X 1/4 LG	8	ATT PT
- 30	38442	. SCREW, MACH-FL CSK HD 6-32 X 1/4 LG	2	ATT PT
- 31	62031	. WASHER, LOCK-INT TEETH NO. 6 X 0.295 OD	10	ATT PT
- 32	730432	. GROMMET, CATERPILLAR	AR	
- 33	5261317	. BRACKET	1	
- 34	10170	. SCREW, MACH-BIND HD 6-32 X 1/4 LG	2	ATT PT
- 35	56722	. WASHER, LOCK-EXT TEETH NO. 6	2	ATT PT
- 36	5261318	. PLATE	1	
- 37	186759	. SCREW, MACH-BIND HD 8-32 X 5/16 LG	2	ATT PT
- 38	38452	. SCREW, MACH-FL CSK HD 8-32 X 5/16 LG	1	ATT PT
- 39	352825	. COVER-TERMINAL 12 ON 40	1	
- 40	10170	. SCREW, MACH-BIND HD 6-32 X 1/4 LG	2	ATT PT
- 41	5708939	. CAPACITOR ASM- 0.100MFD P/M 10% 100VDC	1	
- 42	323839	. TERMINAL BOARD- 12 OBL SCREW TERMINALS	1	
- 43	210883	. STUD-SHIELD MTG, TAPPED, NO. 6-32	2	ATT PT
- 44	35739	. SCREW, MACH-BIND HD 6-32 X 15/16 LG	3	ATT PT
- 45	806569	. STRIP, MARKER	1	
- 46	5261412	. LABEL	1	
- 47	730432	. GROMMET, CATERPILLAR	AR	
- 48	5261423	. TRANSFORMER, POWER	1	
- 49	186758	. SCREW, MACH-BIND HD 8-32 X 0.438	3	ATT PT
- 50	55901	. WASHER, LOCK-EXT TEETH NO. 8 X 0.381 OD	3	ATT PT
- 51	22478	. WASHER, FL- 0.170 ID 0.375 OD 0.32 THK	3	ATT PT
- 52	257189	. NUT, HEX- 8-32	3	ATT PT
- 53	10170	. SCREW, MACH-BIND HD 6-32 X 1/4 LG	2	
- 54	56722	. WASHER, LOCK-EXT TEETH NO. 6	2	
- 55	5261419	. CHOKE, FILTER	1	
- 56	4636	. SCREW, MACH-FL CSK HD 8-32 X 3/8 LG	2	ATT PT
- 57	55901	. WASHER, LOCK-EXT TEETH NO. 8 X 0.381 OD	3	ATT PT
- 58	257189	. NUT, HEX- 8-32	2	ATT PT
- 59	38235	. SCREW, MACH-BIND HD 6-32 X 0.312 LG	1	
- 60	62031	. WASHER, LOCK-INT TEETH NO. 6 X 0.295 OD	1	
- 61	38051	. NUT, PLAIN, HEX- 6-32 X 1/4 FL W STL	1	
- 62	5213402	. RECTIFIER, SILICON	4	
- 63	160017	. NUT, PLAIN, HEX- 1/4-28 X 7/16 FL W	4	ATT PT
- 64	3550	. WASHER, FL- 1/4 X 9/16 OD X 0.050 THK	4	ATT PT
- 65	529691	. WASHER-MICA	3	ATT PT
- 66	217017	. WASHER-INSULATING	3	ATT PT
- 67	65756	. WASHER, LOCK-INT TEETH 0.267 ID X 0.478 OD	4	ATT PT
- 68	473592	. INSULATOR	3	
- 69	478043	. JUMPER - PLATE	1	
- 70	5762386	. TERMINAL	2	
- 71	5261320	. HEAT SINK	1	
- 72	34512	. SCREW, BIND HD 8-32 X .375 LG	4	ATT PT
- 73	337549	. INSULATOR - HEAT SINK MOUNTING	4	
- 74	55726	. SCREW, MACH-BIND HD 6-32 X .188 LG	1	
- 75	5261379	. PIN, STRAIGHT DOWEL	2	
- 76	5261315	. ADAPTER-CAPTIVE SCREW	2	
- 77	5261314	. SCREW, CAPTIVE- 10-32 X 1/2 LG	2	ATT PT
- 78	5261236	. PLATE	1	

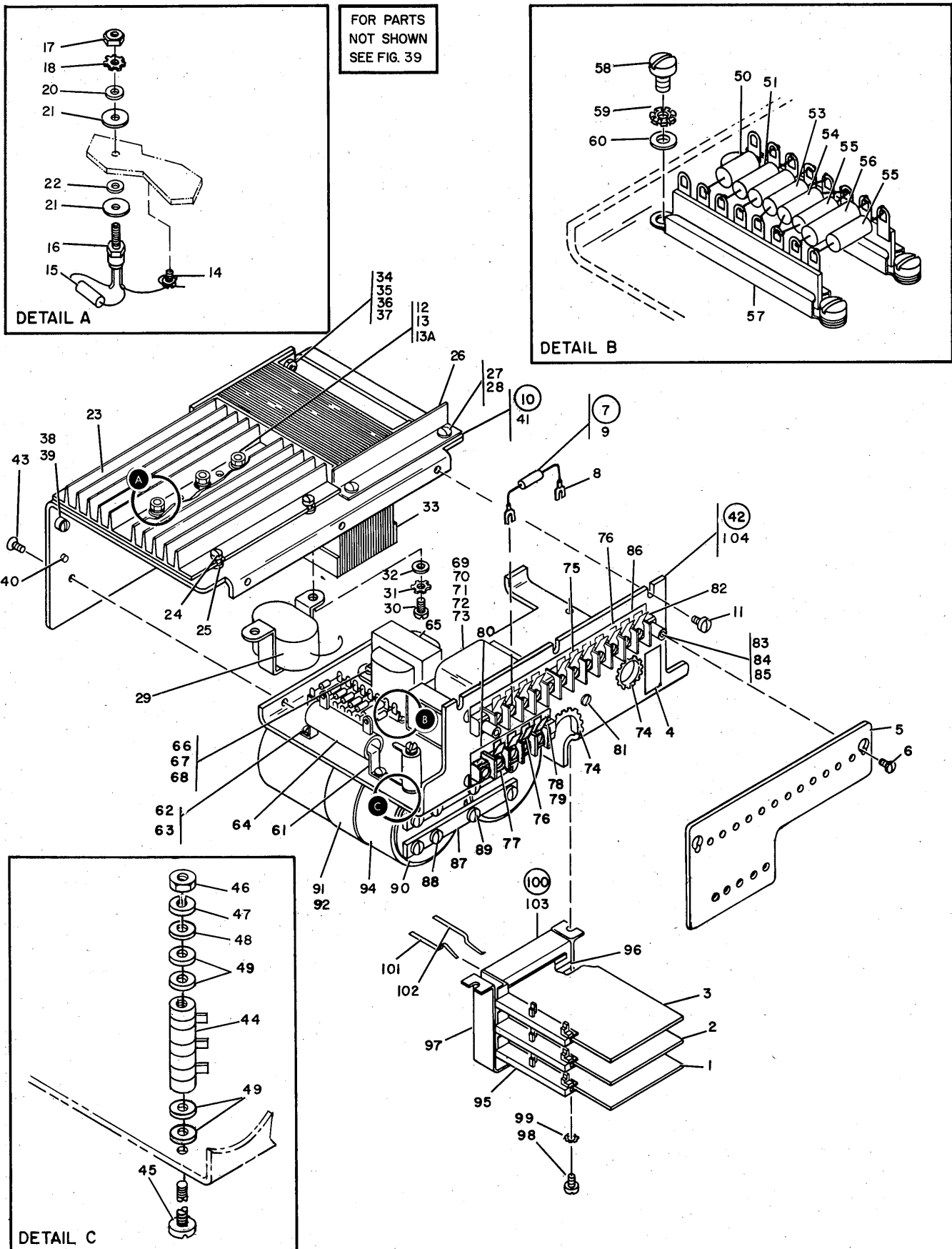

FIGURE 45. 18VDC AT 11 AMP POWER SUPPLY ASSEMBLY.

LIST 45. 18VDC AT 11 AMP POWER SUPPLY ASSEMBLY

FIGURE- INDEX NUMBER	PART NUMBER	DESCRIPTION	UNITS PER ASM.	USABLE ON CODE
45 -	5709320	18 VDC AT 11 AMP POWER SUPPLY ASSEMBLY FOR NEXT HIGHER ASM, SEE FIG. 39-30	REF	
- 1	374772	. CARD ASM	1	
- 2	374826	. CARD ASSEMBLY	1	
- 3	374981	. CARD ASSEMBLY	1	
- 4	5261412	. LABEL	1	
- 5	5253820	. COVER-TERM BOARD	1	
- 6	10170	. SCREW,MACH-BIND HD 6-32 X 1/4 LG ATT PT	2	
- 7	5708939	. CAPACITOR ASM- 0.100MFD P/M 10% 100VDC	1	
- 8	334921	. TERMINAL-RING,18-22 AWG,#6 HOLE,INS	2	
- 9	217077	. CAPACITOR,FXD-POLY- .1MFD P/M 10% 100VDC	1	
- 10	5709325	. PLATE ASSEMBLY,BOTTOM,POWER SUPPLY,18VDC	1	
- 11	81693	. SCREW,MACH-BIND HD 6-32 X 3/8 LG ATT PT	3	
- 12	216197	. RECTIFIER,SILICON-ALLOY	1	
- 13	11891	. NUT-PLAIN,HEX,10-32 X 3/8 FL W BRS ATT PT	1	
- 13A	56079	. WASHER,LOCK-EXT T .195 ID .410 OD ATT PT	1	
- 14	5319854	. SCREW,THD CUTTING-HEX HD 8-32 X 0.375 LG	2	
- 15	529203	. CAPACITOR,FIXED,TANTALUM-47 UF 35V	2	
- 16	5214104	. SEMICONDUCTOR- 11.5A 400V	2	
- 17	160017	. NUT,PLAIN,HEX- 1/4-28 X 7/16 FL W ATT PT	2	
- 18	76574	. LOCKWASHER-EXT TOOTH ID .267 X OD .510 ATT PT	2	
- 20	3550	. WASHER,FL- 1/4 X 9/16 OD X 0.050 THK ATT PT	2	
- 21	217017	. WASHER-INSULATING ATT PT	4	
- 22	5351173	. BUSHING-INSULATOR	2	
- 23	5253807	. HEAT SINK-DIODE	1	
- 24	337	. SCREW,MACH-FIL H 8-32 X 3/8 LG ATT PT	4	
- 25	337549	. INSULATOR - HEAT SINK MOUNTING	4	
- 26	5253827	. BRACKET-AIR TRANSFER	1	
- 27	55726	. SCREW,MACH-BIND HD 6-32 X .188 LG ATT PT	2	
- 28	56722	. WASHER,LOCK-EXT TEETH NO. 6 ATT PT	2	
- 29	5253835	. TRANSFORMER	1	
- 30	55726	. SCREW,MACH-BIND HD 6-32 X .188 LG ATT PT	2	
- 31	56722	. WASHER,LOCK-EXT TEETH NO. 6 ATT PT	2	
- 32	257986	. WASHER,FLAT NO. 6 ATT PT	2	
- 33	5253803	. TRANSFORMER-POWER STEP-DOWN	1	
- 34	367	. SCREW,MACH-FL CSK HD 10-32 X 5/8 LG ATT PT	4	
- 35	45690	. WASHER, FL - NO.10 X 7/16 OD X 1/32 THK ATT PT	4	
- 36	56079	. WASHER,LOCK-EXT T .195 ID .410 OD ATT PT	4	
- 37	11598	. NUT,PLAIN-HEX 10-32 X 3/8 FL W ATT PT	4	
- 38	5261315	. ADAPTER-CAPTIVE SCREW	2	
- 39	5261314	. SCREW,CAPTIVE- 10-32 X 1/2 LG ATT PT	2	
- 40	5261379	. PIN,STRAIGHT DOWEL	2	
- 41	5253796	. PLATE-POWER SUPPLY MTG	1	
- 42	5709323	. PLATE ASSEMBLY,TOP,POWER SUPPLY,18VDC	1	
- 43	38443	. SCREW,MACH-FL CSK HD 6-32 X 5/16 LG ATT PT	3	
- 44	437261	. RESISTOR,VARIABLE,WIREWOUND	1	
- 45	438592	. SCREW,MACH-BIND HD 8-32 X 2-1/4 LG ATT PT	1	
- 46	257189	. NUT,HEX- 8-32 ATT PT	1	
- 47	60646	. WASHER,LOCK-INT T NO. 8 ATT PT	1	
- 48	22478	. WASHER,FL- 0.170 ID 0.375 OD 0.32 THK ATT PT	1	
- 49	419130	. WASHER,MICA,.195 I.D.,5/8 O.D.X.002 THCK ATT PT	4	
- 50	335138	. RESISTOR,FXD,COMP- 200 OHMS P/M 5% 2W	1	
- 51	321271	. RESISTOR,FXD,COMP- 10 OHMS P/M 5% 1/2W	1	
- 53	492448	. RESISTOR,FXD,FILM- 130 OHMS P/M 5% 2W	1	
- 54	213693	. RESISTOR,FXD,COMP- 1K P/M 5% 1/2W	1	
- 55	317276	. RESISTOR,FXD,COMP- 1.2K P/M 5% 1/2W	2	
- 56	529203	. CAPACITOR,FIXED,TANTALUM-47 UF 35V	1	
- 57	317200	. TERMINAL BOARD- 8 LUG TERMINALS	2	
- 58	55726	. SCREW,MACH-BIND HD 6-32 X .188 LG ATT PT	4	
- 59	56722	. WASHER,LOCK-EXT TEETH NO. 6 ATT PT	4	
- 60	257986	. WASHER,FLAT NO. 6 ATT PT	4	
- 61	510316	. BRACKET-MTG,25W RESISTOR	2	
- 62	55726	. SCREW,MACH-BIND HD 6-32 X .188 LG ATT PT	2	
- 63	56722	. WASHER,LOCK-EXT TEETH NO. 6 ATT PT	2	
- 64	353632	. RESISTOR-WIREWOUND 25 OHMS 25 WATTS	1	
- 65	5266044	. TRANSFORMER,CONTROL	1	
- 66	10170	. SCREW,MACH-BIND HD 6-32 X 1/4 LG ATT PT	2	
- 67	56722	. WASHER,LOCK-EXT TEETH NO. 6 ATT PT	2	
- 68	257986	. WASHER,FLAT NO. 6 ATT PT	2	
- 69	5253839	. CHOKE,FILTER-5KC 1MH AT 12.2 AMP	1	
- 70	119	. SCREW,MACH-FL CSK HD 8-32 X 1/2 LG ATT PT	4	
- 71	22478	. WASHER,FL- 0.170 ID 0.375 OD 0.32 THK ATT PT	4	
- 72	55901	. WASHER,LOCK-EXT TEETH NO. 8 X 0.381 OD ATT PT	4	
- 73	257189	. NUT,HEX- 8-32 ATT PT	4	

LIST 45. 18VDC AT 11 AMP POWER SUPPLY ASSEMBLY

FIGURE- INDEX NUMBER	PART NUMBER	DESCRIPTION	UNITS PER ASM.	USABLE ON CODE
45 - 74	730432	. GROMMET,CATERPILLAR	AR	
- 75	5276270	. TAB,TERMINAL	15	
- 76	5276271	. TAB,TERMINAL	15	
- 77	5253824	. TERMINAL BOARD-4 POS	1	
- 78	322550	. SCREW,MACH,BIND HD- 6-32 X .5 LG ATT PT	2	
- 79	56722	. WASHER,LOCK-EXT TEETH NO. 6 ATT PT	2	
- 80	5253823	. MARKER STRIP-4 POS	1	
- 81	10170	. SCREW,MACH-BIND HD 6-32 X 1/4 LG	1	
- 82	5253845	. TERMINAL BOARD-12 POS	1	
- 83	210883	. STUD-SHIELD MTG,TAPPED,NO. 6-32 ATT PT	2	
- 84	56722	. WASHER,LOCK-EXT TEETH NO. 6 ATT PT	2	
- 85	257986	. WASHER,FLAT NO. 6 ATT PT	2	
- 86	5253825	. MARKER STRIP-12 POS	1	
- 87	5253804	. BUS BAR-CAPACITOR	2	
- 88	32042	. SCREW, MACH BIND. HD 10-32 X 3/8 LG. ATT PT	4	
- 89	236849	. SCREW,MACH-BIND HD 10-32 X 0.250 LG ATT PT	4	
- 90	5240477	. SHIELD,CAPACITOR	2	
- 91	5253822	. BRACKET-CAPACITOR MTG	1	
- 92	438602	. SCREW,MACH-BIND HD 10-32 X 1-1/2 LG ATT PT	1	
- 94	1143248	. CAPACITOR,FIXED,ELECT-1500 UF 25V	2	
- 95	216206	. GUIDE-SINGLE CARD LONG	3	
- 96	473547	. SPACER,1 X 2 3/8 IN .12 IN THICK	2	
- 97	5253806	. BRACKET-CONNECTOR MTG	1	
- 98	10170	. SCREW,MACH-BIND HD 6-32 X 1/4 LG ATT PT	2	
- 99	56722	. WASHER,LOCK-EXT TEETH NO. 6 ATT PT	2	
-100	216076	. TERMINAL BLOCK AND CONTACT ASSEMBLY	3	
-101	216088	. SPRING-CONTACT	24	
-102	216087	. SPRING-CONTACT	24	
-103	216073	. TERMINAL BLOCK AND CONTACT ASSEMBLY	3	
-104	5253797	. PLATE-POWER SUPPLY MTG	1	

FOR PARTS
NOT SHOWN
SEE FIG. 37
SHEET 1

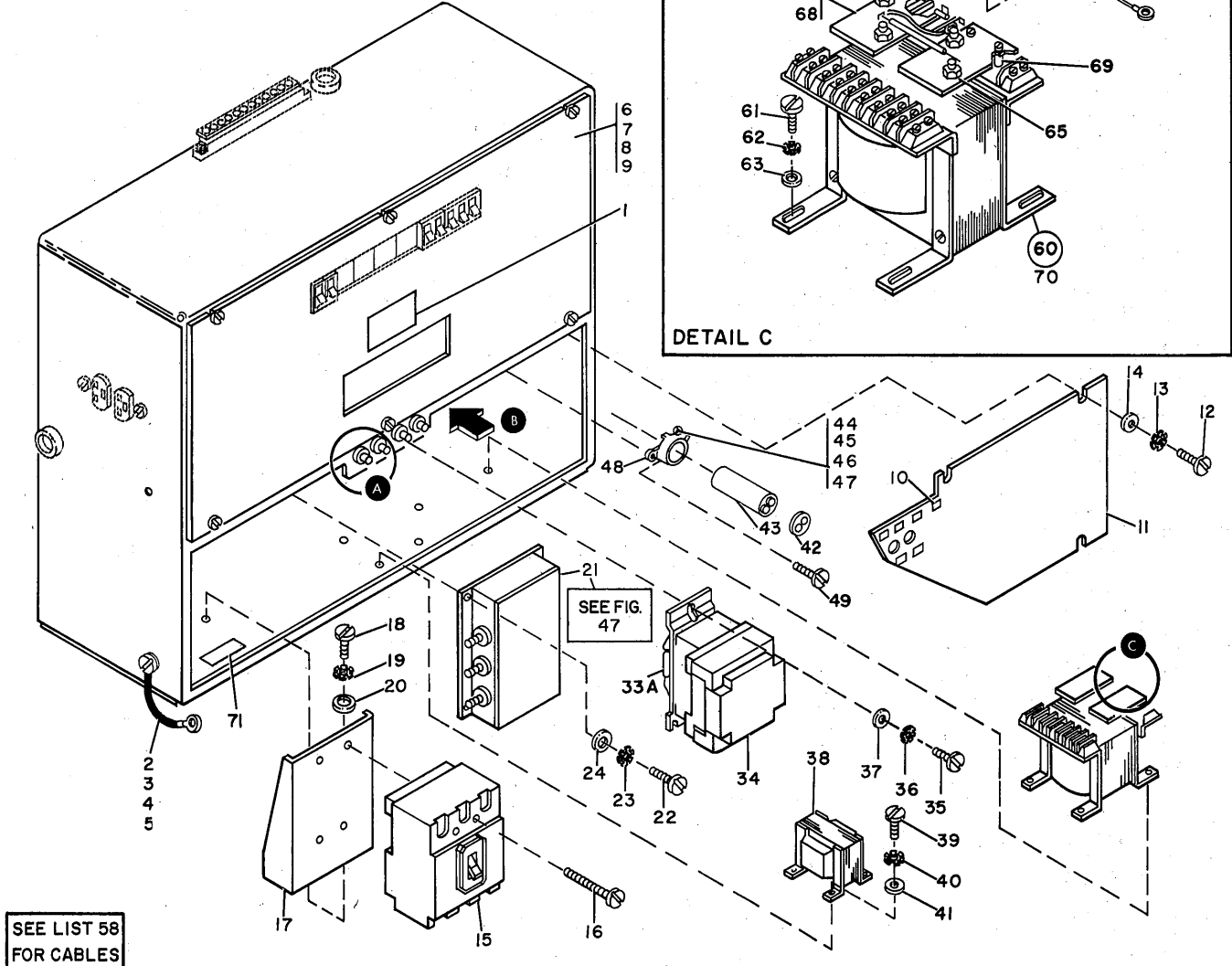
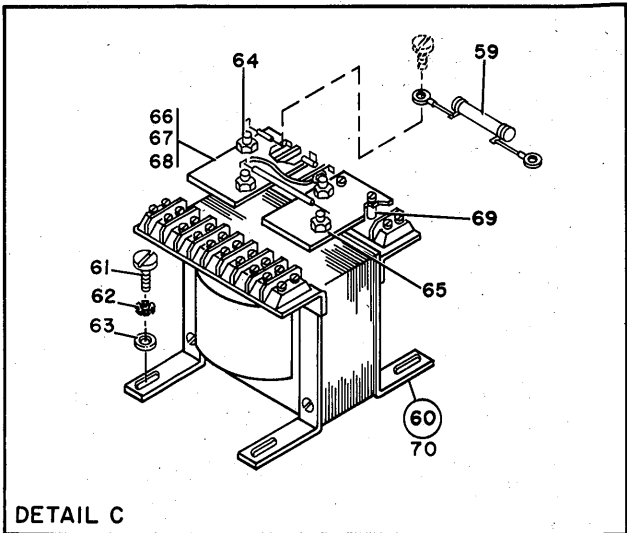

SEE LIST 58
FOR CABLES

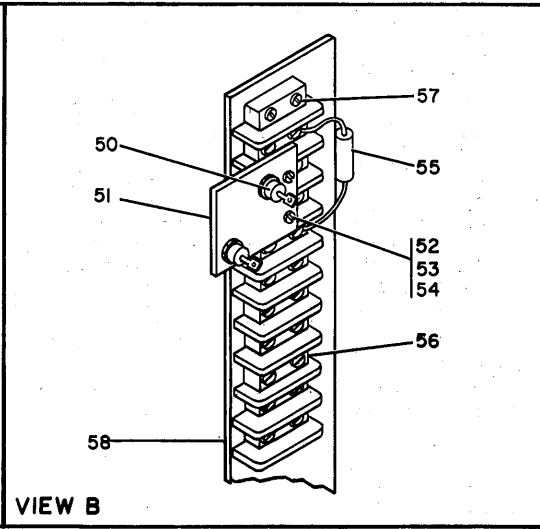
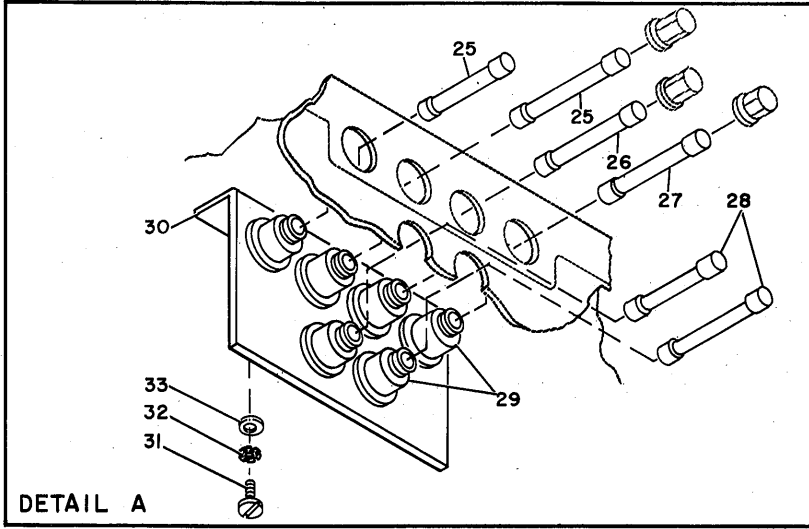
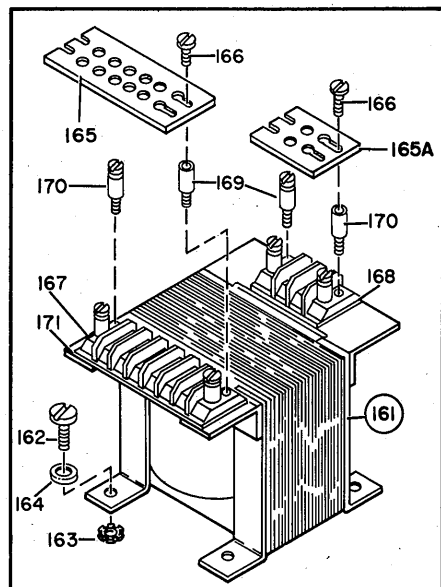
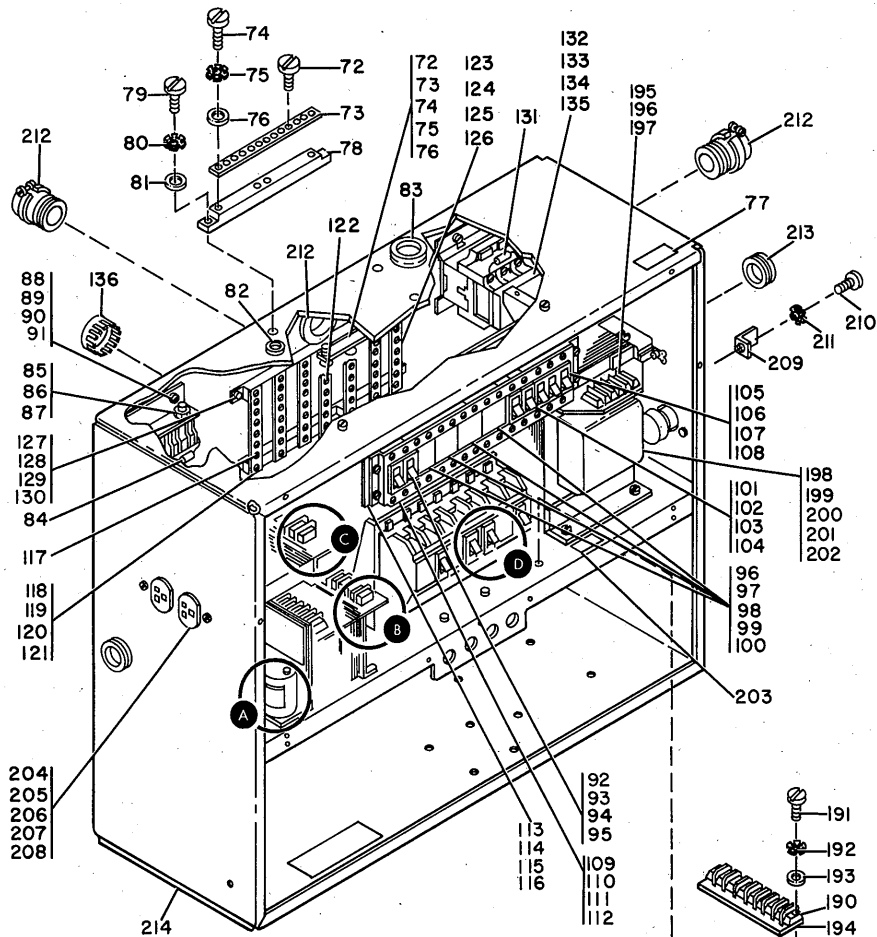

FIGURE 46. POWER BOX ASSEMBLY. (SHEET 1 OF 2, INDEX NOS. 1-71)

LIST 46. POWER BOX ASSEMBLY

FIGURE- INDEX NUMBER	PART NUMBER	DESCRIPTION	UNITS PER ASM.	USABLE ON CODE
46 -	5781319	POWER BOX ASSEMBLY FOR NEXT HIGHER ASM, SEE FIGURE 37-37	REF	
- 1	369207	. LABEL, VOLTAGE	1	
- 2	5236967	. JUMPER ASM-GRN/YEL 6 IN. 10AWG 1 LUG EA FOR COMPONENT PARTS SEE FIG. 59-34A	2	
- 3	32042	. SCREW, MACH BIND. HD 10-32 X 3/8 LG.	ATT PT 4	
- 4	56079	. WASHER, LOCK-EXT T .195 ID .410 OD	ATT PT 4	
- 5	11598	. NUT, PLAIN-HEX 10-32 X 3/8 FL W	ATT PT 2	
- 6	5722159	. COVER, TOP, POWER BOX	1	
- 7	34512	. SCREW, BIND. HD 8-32 X .375 LG	ATT PT 8	
- 8	55901	. WASHER, LOCK-EXT TEETH NO. 8 X 0.381 OD	ATT PT 8	
- 9	22478	. WASHER, FL- 0.170 ID 0.375 OD 0.32 THK	ATT PT 8	
- 10	5236723	. STRIP, NUMBERING	6	
- 11	5781480	. COVER	1	
- 12	34512	. SCREW, BIND. HD 8-32 X .375 LG	ATT PT 7	
- 13	55901	. WASHER, LOCK-EXT TEETH NO. 8 X 0.381 OD	ATT PT 7	
- 14	22478	. WASHER, FL- 0.170 ID 0.375 OD 0.32 THK	ATT PT 7	
- 15	519043	. CIRCUIT BREAKER- 3P 240V AC 50 AMP	1	
- 16	322563	. SCREW	ATT PT 4	
- 17	5276291	. BRACKET, MOUNTING, CIRCUIT BREAKER	1	
- 18	32042	. SCREW, MACH BIND. HD 10-32 X 3/8 LG.	ATT PT 3	
- 19	56079	. WASHER, LOCK-EXT T .195 ID .410 OD	ATT PT 4	
- 20	45690	. WASHER, FL - NO.10 X 7/16 OD X 1/32 THK	ATT PT 3	
- 21	5276306	. LINE FILTER ASSEMBLY	1	
		FOR DETAIL BREAKDOWN SEE FIGURE 47.		
- 22	32042	. SCREW, MACH BIND. HD 10-32 X 3/8 LG.	ATT PT 4	
- 23	56079	. WASHER, LOCK-EXT T .195 ID .410 OD	ATT PT 4	
- 24	45690	. WASHER, FL - NO.10 X 7/16 OD X 1/32 THK	ATT PT 4	
- 25	111264	. FUSE, CARTRIDGE-TIME DELAY 3/4 AMP 250V	2	
- 26	511063	. FUSE, CARTRIDGE 10 AMP	1	
- 27	123786	. FUSE, CARTRIDGE- 5 AMP 250V	1	
- 28	111256	. FUSE-1.5 AMP	2	
- 29	360882	. FUSEHOLDER- 15 AMP 250V AC	6	
- 30	5781481	. BRACKET-FUSE MTG	1	
- 31	10170	. SCREW, MACH-BIND HD 6-32 X 1/4 LG	ATT PT 2	
- 32	56722	. WASHER, LOCK-EXT TEETH NO. 6	ATT PT 2	
- 33	257986	. WASHER, FLAT NO. 6	ATT PT 2	
- 33A	599917	. DIODE AND LUG TERMINAL ASSEMBLY	1	
- 34	5270586	. RELAY-24 VDC COIL	1	
- 35	34512	. SCREW, BIND. HD 8-32 X .375 LG	ATT PT 3	
- 36	55901	. WASHER, LOCK-EXT TEETH NO. 8 X 0.381 OD	ATT PT 4	
- 37	22478	. WASHER, FL- 0.170 ID 0.375 OD 0.32 THK	ATT PT 3	
- 38	5351205	. CHOKE, FILTER	1	
- 39	34512	. SCREW, BIND. HD 8-32 X .375 LG	ATT PT 4	
- 40	55901	. WASHER, LOCK-EXT TEETH NO. 8 X 0.381 OD	ATT PT 5	
- 41	22478	. WASHER, FL- 0.170 ID 0.375 OD 0.32 THK	ATT PT 4	
- 42	5762073	. PLATE-SAFETY	1	
- 43	5214167	. CAPACITOR	1	
- 44	5528	. SCREW, MACH BIND HD 8-32 X .625 LG	1	
- 45	22478	. WASHER, FL- 0.170 ID 0.375 OD 0.32 THK	1	
- 46	55901	. WASHER, LOCK-EXT TEETH NO. 8 X 0.381 OD	1	
- 47	257189	. NUT, HEX- 8-32	1	
- 48	320456	. BRACKET-CAPACITOR MOUNTING	1	
- 49	10170	. SCREW, MACH-BIND HD 6-32 X 1/4 LG	ATT PT 3	
- 50	598353	. SEMICONDUCTOR DEVICE, D10- 100V 10 AMP	2	
- 51	5351123	. HEAT SINK	1	
- 52	322551	. SCREW, MACH-BIND HD 6-32X3/4 LG	ATT PT 2	
- 53	56722	. WASHER, LOCK-EXT TEETH NO. 6	ATT PT 3	
- 54	56792	. SPACER- .156 ID 5/16 OD X .343 LG	2	
- 55	2573847	. DIODE	1	
- 56	317145	. TERMINAL BOARD- 8 DBL SCREW TERMINALS	1	
- 57	25627	. SCREW-BD. HD 8-32 X .50C LG	ATT PT 4	
- 58	628962	. STRIP, MARKER	1	
- 59	5351206	. RESISTOR ASSEMBLY	1	
- 60	5351120	. AC POWER SUPPLY SUB ASSEMBLY	1	
- 61	32042	. SCREW, MACH BIND. HD 10-32 X 3/8 LG.	ATT PT 4	
- 62	56079	. WASHER, LOCK-EXT T .195 ID .410 OD	ATT PT 5	
- 63	45690	. WASHER, FL - NO.10 X 7/16 OD X 1/32 THK	ATT PT 4	
- 64	598355	. RECTIFIER, SILICON	2	
- 65	598353	. SEMICONDUCTOR DEVICE, D10- 100V 10 AMP	2	
- 66	5351123	. HEAT SINK	2	
- 67	322551	. SCREW, MACH-BIND HD 6-32X3/4 LG	ATT PT 4	
- 68	56722	. WASHER, LOCK-EXT TEETH NO. 6	ATT PT 4	
- 69	56792	. SPACER- .156 ID 5/16 OD X .343 LG	4	
- 70	5351121	. TRANSFORMER, PWR-PRI 104-235V SECD 14-28V	1	
- 71	138756	. PLATE, INST-LINE V PRESENT W/MACH PWR OFF	1	



DETAIL C

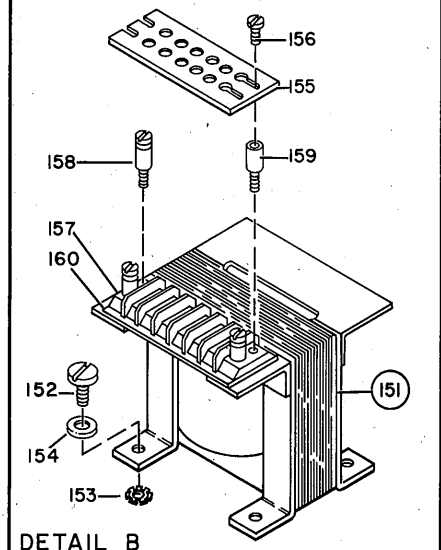

DETAIL B

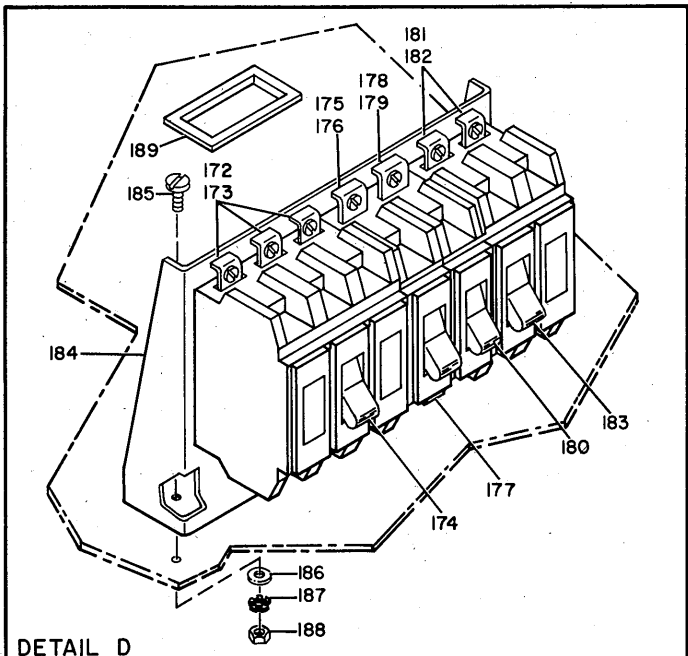

DETAIL D

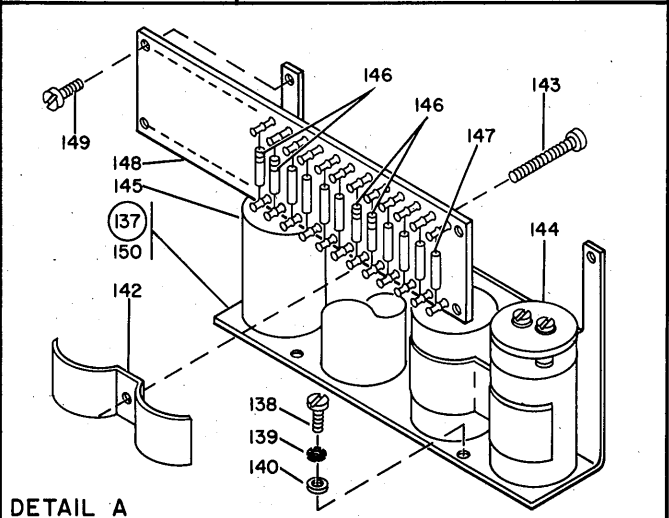

DETAIL A

FIGURE 46. POWER BOX ASSEMBLY. (SHEET 2 OF 2, INDEX NOS. 72-215)

LIST 46. POWER BOX ASSEMBLY

FIGURE- INDEX NUMBER	PART NUMBER	DESCRIPTION	UNITS PER ASM.	USABLE ON CODE
46-72	58207	• SCREW,MACH-UNDRCT BIND HD 8-32 X 1/4 LG	22	
-73	5235293	• BUS BAR	2	
-74	25627	• SCREW-BD. HD 8-32 X .500 LG	4	ATT PT
-75	55901	• WASHER,LOCK-EXT TEETH NO. 8 X 0.381 OD	6	ATT PT
-76	22478	• WASHER,FL- 0.170 ID 0.375 OD 0.32 THK	4	ATT PT
-77	845762	• DECAL-VOLTAGE	1	
-78	5235292	• INSULATOR-BUS BAR	1	
-79	34512	• SCREW,BIND.HD 8-32 X .375 LG	2	ATT PT
-80	55901	• WASHER,LOCK-EXT TEETH NO. 8 X 0.381 OD	2	ATT PT
-81	22478	• WASHER,FL- 0.170 ID 0.375 OD 0.32 THK	2	ATT PT
-82	317138	• GROMMET,RUB-FOR 7/16 HOLE X 1/8 PNL	1	
-83	510388	• GROMMET,1/2IN X 1/8 DIA	2	
-84	2111232	• SEMICONDUCTOR DEVICE,DIODE-TYPE AM	2	
-85	2128689	• RELAY,3 POLE DT 472 OHM 24 VOLT D.C.COIL	2	
-86	257187	• NUT,PLAIN,HEX- 6-32 X 3/8 FL W	2	ATT PT
-87	56722	• WASHER,LOCK-EXT TEETH NO. 6	2	ATT PT
-88	5781468	• BRACKET-RELAY	1	
-89	32042	• SCREW, MACH BIND. HD 10-32 X 3/8 LG.	1	ATT PT
-90	32042	• SCREW, MACH BIND. HD 10-32 X 3/8 LG.	1	ATT PT
-91	11598	• NUT,PLAIN-HEX 10-32 X 3/8 FL W	1	ATT PT
-92	5270651	• CIRCUIT BREAKER-DP 0.4 AMP	1	
-93	10170	• SCREW,MACH-BIND HD 6-32 X 1/4 LG	4	ATT PT
-94	56722	• WASHER,LOCK-EXT TEETH NO. 6	4	ATT PT
-95	257986	• WASHER,FLAT NO. 6	4	ATT PT
-96	5722145	• PLATE-CB,BLANK	4	
-97	81693	• SCREW,MACH-BIND HD 6-32 X 3/8 LG	16	ATT PT
-98	257986	• WASHER,FLAT NO. 6	16	ATT PT
-99	56722	• WASHER,LOCK-EXT TEETH NO. 6	16	ATT PT
-100	257187	• NUT,PLAIN,HEX- 6-32 X 3/8 FL W	16	ATT PT
-101	5270566	• CIRCUIT BREAKER-DP 0.8 AMP	1	
-102	10170	• SCREW,MACH-BIND HD 6-32 X 1/4 LG	4	ATT PT
-103	56722	• WASHER,LOCK-EXT TEETH NO. 6	4	ATT PT
-104	257986	• WASHER,FLAT NO. 6	4	ATT PT
-105	5213479	• CIRCUIT BREAKER,3 POLE SPDT	1	
-106	10170	• SCREW,MACH-BIND HD 6-32 X 1/4 LG	6	ATT PT
-107	56722	• WASHER,LOCK-EXT TEETH NO. 6	6	ATT PT
-108	257986	• WASHER,FLAT NO. 6	6	ATT PT
-109	5276288	• PLATE,MOUNTING,CIRCUIT BREAKER	1	
-110	32042	• SCREW, MACH BIND. HD 10-32 X 3/8 LG.	4	ATT PT
-111	56079	• WASHER,LOCK-EXT T .195 ID .410 OD	4	ATT PT
-112	45690	• WASHER, FL - NO.10 X 7/16 OD X 1/32 THK	4	ATT PT
-113	5276289	• BRACKET,MOUNTING,CIRCUIT BREAKER	2	
-114	32042	• SCREW, MACH BIND. HD 10-32 X 3/8 LG.	4	ATT PT
-115	56079	• WASHER,LOCK-EXT T .195 ID .410 OD	4	ATT PT
-116	45690	• WASHER, FL - NO.10 X 7/16 OD X 1/32 THK	4	ATT PT
-117	32042	• SCREW, MACH BIND. HD 10-32 X 3/8 LG.	18	
-118	5276286	• BUS BAR	3	
-119	186758	• SCREW,MACH-BIND HD 8-32 X 0.438	6	ATT PT
-120	55901	• WASHER,LOCK-EXT TEETH NO. 8 X 0.381 OD	6	ATT PT
-121	22478	• WASHER,FL- 0.170 ID 0.375 OD 0.32 THK	6	ATT PT
-122	34512	• SCREW,BIND.HD 8-32 X .375 LG	28	
-123	5235365	• BUS BAR	4	
-124	34512	• SCREW,BIND.HD 8-32 X .375 LG	8	ATT PT
-125	55901	• WASHER,LOCK-EXT TEETH NO. 8 X 0.381 OD	8	ATT PT
-126	22478	• WASHER,FL- 0.170 ID 0.375 OD 0.32 THK	8	ATT PT
-127	5276287	• INSULATOR,BUS BAR	2	
-128	34512	• SCREW,BIND.HD 8-32 X .375 LG	6	ATT PT
-129	55901	• WASHER,LOCK-EXT TEETH NO. 8 X 0.381 OD	6	ATT PT
-130	22478	• WASHER,FL- 0.170 ID 0.375 OD 0.32 THK	6	ATT PT
-131	599917	• DIODE AND LUG TERMINAL ASSEMBLY	1	
-132	5276329	• CONTACTOR, MAGNETIC	1	
-133	34512	• SCREW,BIND.HD 8-32 X .375 LG	2	ATT PT
-134	55901	• WASHER,LOCK-EXT TEETH NO. 8 X 0.381 OD	3	ATT PT
-135	22478	• WASHER,FL- 0.170 ID 0.375 OD 0.32 THK	2	ATT PT
-136	208528	• BUTTON,PLUG-FOR 1-3/8 DIA HOLE	2	
-137	5276294	• POWER SUPPLY ASSEMBLY,OVERVOLTAGE-SENSE	1	
-138	34512	• SCREW,BIND.HD 8-32 X .375 LG	3	ATT PT
-139	55901	• WASHER,LOCK-EXT TEETH NO. 8 X 0.381 OD	4	ATT PT
-140	22478	• WASHER,FL- 0.170 ID 0.375 OD 0.32 THK	3	ATT PT
-142	552994	• CLAMP-CAPACITOR	2	
-143	438588	• SCREW,MACH-UNDRCT BIND HD 8-32 X 1-1/4	2	ATT PT
-144	361503	• COVER-CAPACITOR	4	
-145	483106	• CAPACITOR-CAN TYPE-ELECTROLYTIC 1500MFD	4	
-146	317015	• RESISTOR,FXD,COMP- 750 OHMS P/M 5% 1/2W	4	
-147	5323537	• SEMICONDUCTOR DEVICE,DIO- 200V 6 AMP	8	
-148	5276356	• TERMINAL BOARD	1	
-149	338238	• SCREW, MACH-BD HD 4-40 NC X .3125 LG	4	ATT PT
-150	5276364	• BRACKET,POWER SUPPLY-OVERVOLTAGE	1	

LIST 46. POWER BOX ASSEMBLY

FIGURE- INDEX NUMBER	PART NUMBER	DESCRIPTION	UNITS PER ASM.	USABLE ON CODE
46-151	5213435	• TRANSFORMER ASM	1	
-152	32042	• SCREW, MACH BIND. HD 10-32 X 3/8 LG.	4	ATT PT
-153	56079	• WASHER,LOCK-EXT T .195 ID .410 OD	5	ATT PT
-154	45690	• WASHER, FL - NO.10 X 7/16 OD X 1/32 THK	4	ATT PT
-155	191480	• SHIELD,8 POSITION	2	
-156	210984	• SCREW, RD HD MACH-6-32 X .250 LG	2	ATT PT
-157	322766	• BLOCK,TERMINAL	2	
-158	210884	• STUD-SHIELD MTG,NO. 6-32	6	ATT PT
-159	210883	• STUD-SHIELD MTG,TAPPED,NO. 6-32	2	ATT PT
-160	126036	• MARKER STRIP,INSULATING	1	
-161	5213436	• TRANSFORMER ASM	1	
-162	32042	• SCREW, MACH BIND. HD 10-32 X 3/8 LG.	4	ATT PT
-163	56079	• WASHER,LOCK-EXT T .195 ID .410 OD	5	ATT PT
-164	45690	• WASHER, FL - NO.10 X 7/16 OD X 1/32 THK	4	ATT PT
-165	186944	• SHIELD,TERMINAL BOARD- 6 POSITION	2	
-165A	187467	• SHIELD, 2 POSITION	1	
-166	210984	• SCREW, RD HD MACH-6-32 X .250 LG	2	ATT PT
-167	317131	• TERMINAL BOARD- 6 DBL SCREW TERMINALS	1	
-168	323840	• TERMINAL BOARD- 2 DBL SCREW TERMINALS	1	
-169	210986	• STUD-SHIELD MOUNTING	6	ATT PT
-170	210985	• STUD,EXT-INT 6-32 EXT 8-32 X 0.900 LG OA	2	ATT PT
-171	322266	• MARKER STRIP- 6 POS NOS. 1 THRU 6	1	
-172	5733235	• CLAMP,RIM CLENCHING	6	
-173	322550	• SCREW,MACH,BIND HD- 6-32 X .5 LG	6	ATT PT
-174	5719452	• CIRCUIT BREAKER 40 AMP 240 VOLT, 3 POLE	1	
-175	517892	• STRAP,RETAINING-CIRCUIT BREAKER	2	
-176	322550	• SCREW,MACH,BIND HD- 6-32 X .5 LG	2	ATT PT
-177	517126	• CIRCUIT BREAKER	1	
-178	5733235	• CLAMP,RIM CLENCHING	2	
-179	322550	• SCREW,MACH,BIND HD- 6-32 X .5 LG	2	ATT PT
-180	524966	• CIRCUIT BREAKER	1	
-181	5733235	• CLAMP,RIM CLENCHING	4	
-182	322550	• SCREW,MACH,BIND HD- 6-32 X .5 LG	4	ATT PT
-183	5719456	• CIRCUIT BREAKER 15 AMP 240 VOLT, 2 POLE	1	
-184	5722158	• BRACKET,MOUNTING,CIRCUIT BREAKER	1	
-185	332620	• SCREW,MACH-BIND HD 10-32 X 1/2 LG	3	ATT PT
-186	45690	• WASHER, FL - NO.10 X 7/16 OD X 1/32 THK	3	ATT PT
-187	56079	• WASHER,LOCK-EXT T .195 ID .410 OD	3	ATT PT
-188	11598	• NUT,PLAIN-HEX 10-32 X 3/8 FL W	3	ATT PT
-189	237455	• RUBBER CHANNEL	AR	
-190	323842	• TERMINAL BOARD- 12 DBL SCREW TERMINALS	1	
-191	322550	• SCREW,MACH,BIND HD- 6-32 X .5 LG	4	ATT PT
-192	56722	• WASHER,LOCK-EXT TEETH NO. 6	4	ATT PT
-193	257986	• WASHER,FLAT NO. 6	4	ATT PT
-194	460471	• STRIP,MARKER	1	
-195	337193	• SHIELD-TERMINAL BOARD 6 POSITION	1	
-196	10170	• SCREW,MACH-BIND HD 6-32 X 1/4 LG	2	ATT PT
-197	210883	• STUD-SHIELD MTG,TAPPED,NO. 6-32	2	ATT PT
-198	5271245	• TRANSFORMER,POWER- 2300VA,60CPS- 115V	1	
-199	438623	• SCREW,MACH-BIND HD 1/4-20 X 5/8 LG	4	ATT PT
-200	3550	• WASHER,FL- 1/4 X 9/16 OD X 0.050 THK	4	ATT PT
-201	76574	• LOCKWASHER-EXT TOOTH ID .267 X OD .510	5	ATT PT
-202	3960	• NUT,PLAIN,HEX- 1/4-20 X 7/16 FL W	4	ATT PT
-203	138754	• DECAL,VOLTAGE-ENGLISH,JAPANESE	1	
-204	5213803	• OUTLET,CONVENIENCE- 125V	2	
-205	34512	• SCREW,BIND.HD 8-32 X .375 LG	4	ATT PT
-206	22478	• WASHER,FL- 0.170 ID 0.375 OD 0.32 THK	4	ATT PT
-207	55901	• WASHER,LOCK-EXT TEETH NO. 8 X 0.381 OD	4	ATT PT
-208	257189	• NUT,HEX- 8-32	4	ATT PT
-209	5271288	• TERMINAL,FIXED TAB	1	
-210	251970	• SCREW-MACH BD. HD. 4-40 X 1/4 LG	1	ATT PT
-211	338169	• WASHER,LOCK-EXT TEETH NO. 4 X .260 OD	1	ATT PT
-212	342250	• ADAPTER,CABLE TO CONNECTOR	3	
-213	220764	• GROMMET,RUB-FOR 1-3/8 HOLE X 1/8 PNL	2	
-214	5781469	• BOX-POWER CONTROL	1	

FOR PARTS
NOT SHOWN
SEE FIG. 46
SHEET 1

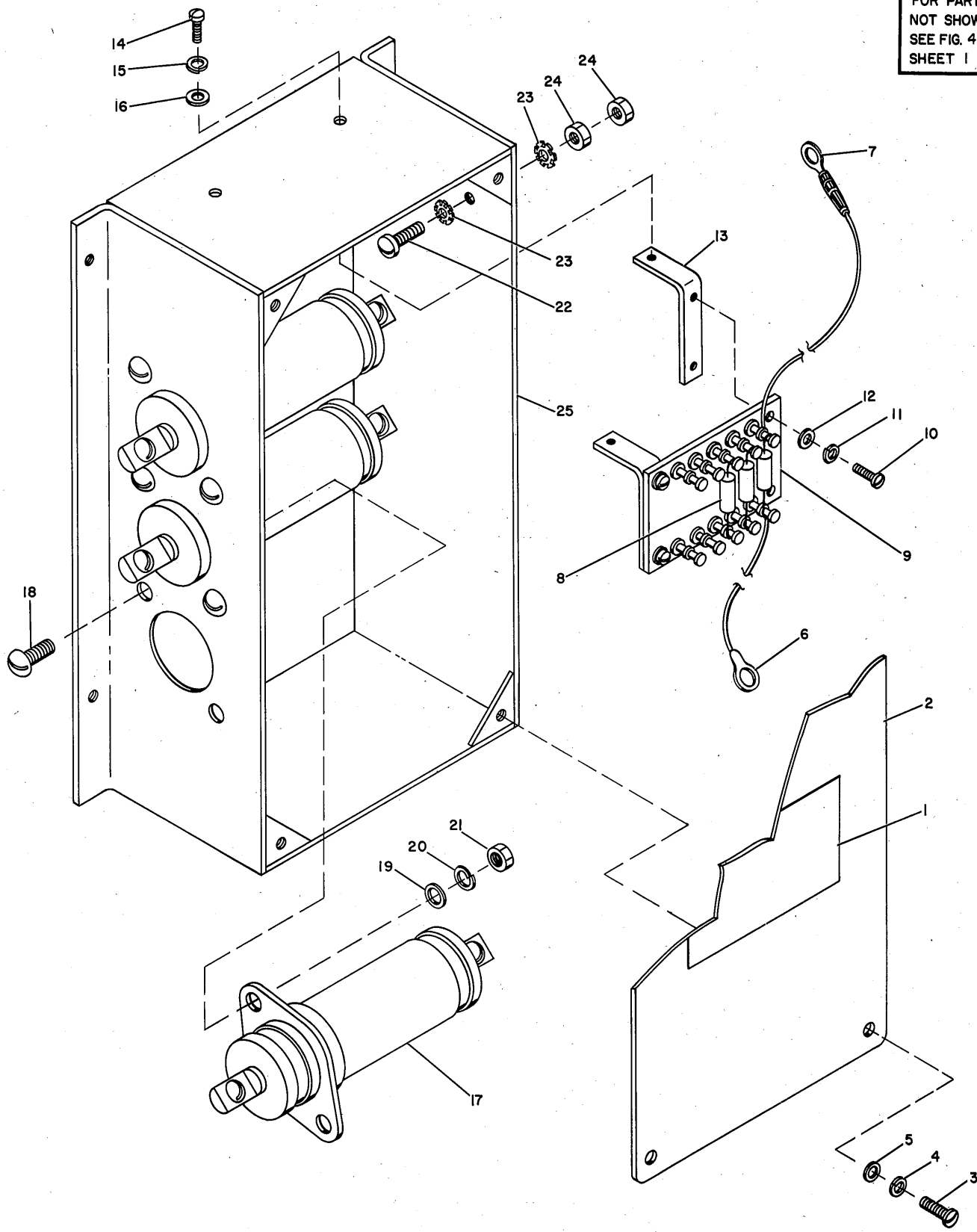

FIGURE 47. LINE FILTER ASSEMBLY.

FOR PARTS
NOT SHOWN
SEE FIG. 37
SHEET 1.

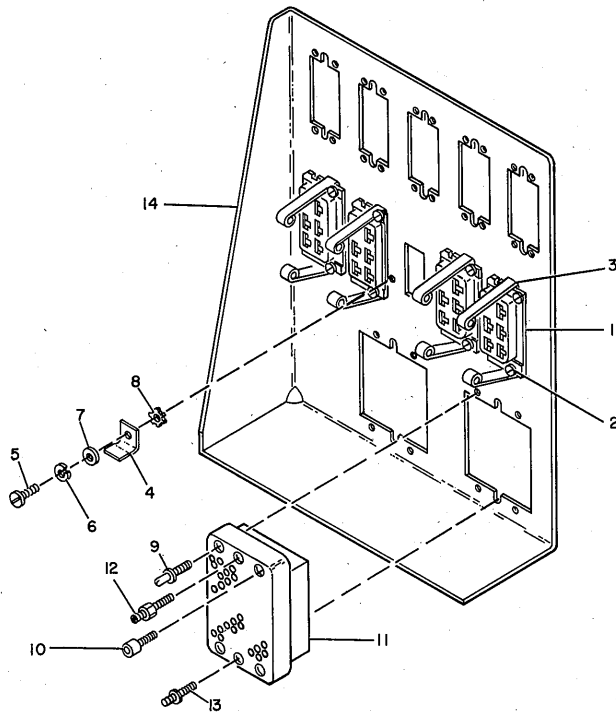

FIGURE 48. RIGHT I/O PANEL ASSEMBLY.

LIST 48. RIGHT I/O PANEL ASSEMBLY

FIGURE- INDEX NUMBER	PART NUMBER	DESCRIPTION				UNITS PER ASM.	USABLE ON CODE
		1	2	3	4		
48 -	5781453	I/O PANEL ASSEMBLY-RIGHT FOR NEXT HIGHER ASM, SEE FIGURE 37-39				REF	
- 1	523269	• CONNECTOR-ELECT 6 POS INSERT				4	
- 2	251970	• SCREW-MACH BD. HD. 4-40 X 1/4 LG				8	ATT PT
- 3	5236960	• SPRING-EPO BRKT				4	
- 4	5271288	• TERMINAL, FIXED TAB				4	
- 5	251970	• SCREW-MACH BD. HD. 4-40 X 1/4 LG				4	ATT PT
- 6	257984	• WASHER, LOCK-SPLIT 1/8 ID X 13/64 OD				4	ATT PT
- 7	257985	• WASHER, FLAT-NO. 4 X 0.250 OD X 0.028 THK				4	ATT PT
- 8	338169	• WASHER, LOCK-EXT TEETH NO. 4 X .260 OD				4	ATT PT
- 9	2122637	• PIN, GUIDE CORNER				2	
- 10	2122636	• SOCKET, GUIDE-CORNER 75 AND 104 POS CONN				2	
- 11	2122625	• BLOCK, FEMALE- 104 POS MINIATURE CONN				1	
- 12	2123028	• JACK SCREW, SOCKET, FIXED				1	ATT PT
- 13	2123029	• JACKSCREW-STUD, FIXED				1	ATT PT
- 14	5781580	• CONNECTOR-PANEL R.H.				1	

FOR PARTS
NOT SHOWN
SEE FIG.37
SHEET 1

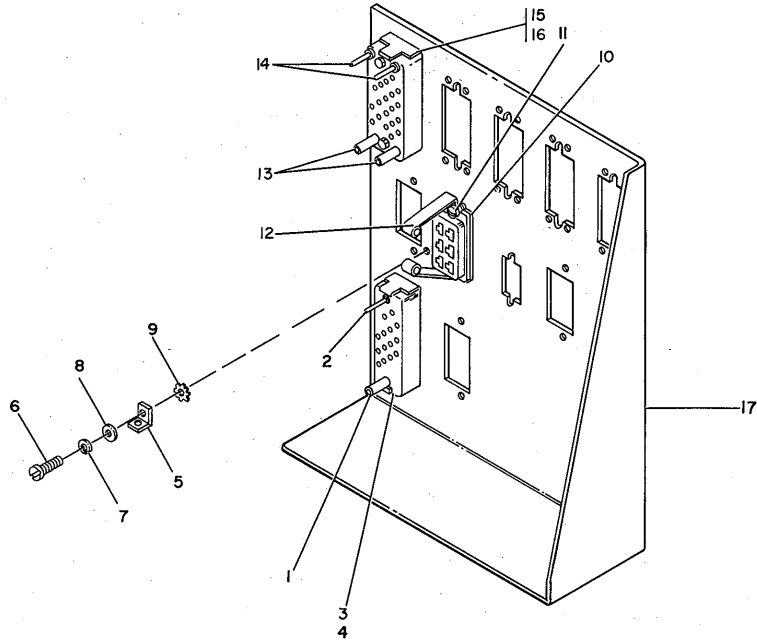

FIGURE 49. LEFT I/O PANEL ASSEMBLY.

LIST 49. LEFT I/O PANEL ASSEMBLY

FIGURE- INDEX NUMBER	PART NUMBER	DESCRIPTION				UNITS PER ASM.	USABLE ON CODE
		1	2	3	4		
49 -	5781452	I/O PANEL ASSEMBLY-LEFT FOR NEXT HIGHER ASM, SEE FIGURE 37-41				REF	
- 1	2122202	• SOCKET, GUIDE-CENTER				1	
- 2	2122203	• PIN, GUIDE, BRASS, 7 SUPPLIED W/HARDWARE/				1	
- 3	2122837	• CONNECTOR, PLUG, ELECTRICAL, FEMALE				1	
- 4	2127987	• CATCH, LOCK SPG-26 POS CONNECTOR				2	ATT PT
- 5	5271288	• TERMINAL, FIXED TAB				3	
- 6	251970	• SCREW-MACH BD. HD. 4-40 X 1/4 LG				3	ATT PT
- 7	257984	• WASHER, LOCK-SPLIT 1/8 ID X 13/64 OD				3	ATT PT
- 8	257985	• WASHER, FLAT-NO. 4 X 0.250 OD X 0.028 THK				3	ATT PT
- 9	338169	• WASHER, LOCK-EXT TEETH NO. 4 X .260 OD				3	ATT PT
- 10	523269	• CONNECTOR-ELECT 6 POS INSERT				1	
- 11	251970	• SCREW-MACH BD. HD. 4-40 X 1/4 LG				2	ATT PT
- 12	5236960	• SPRING-EPO BRKT				1	
- 13	2122735	• PIN-SOCKET GUIDE				2	
- 14	2122734	• PIN, GUIDE CORNER 34 AND 50 POSITION				2	
- 15	2122256	• CCNNECTOR, RECP, ELEC-34 FEMALE CONTACTS				1	
- 16	2127989	• CATCH-LOCKING SPRING				2	ATT PT
- 17	5781581	• PANEL				1	

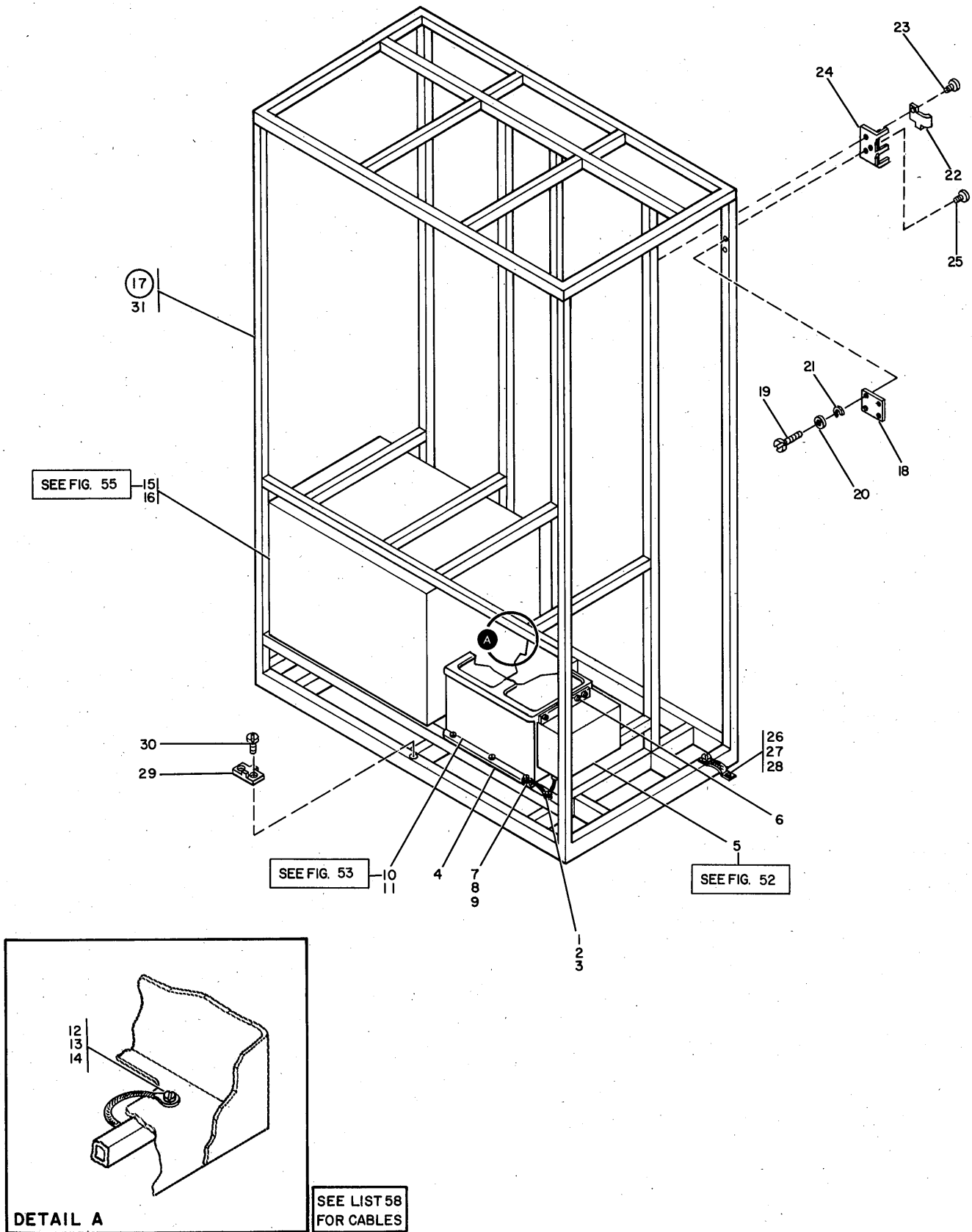

FIGURE 51. WALL FRAME ASSEMBLY- 1 BATTERY-FRAME 09.

LIST 51. WALL FRAME ASSEMBLY- 1 BATTERY-FRAME 09

FIGURE- INDEX NUMBER	PART NUMBER	DESCRIPTION	UNITS PER ASM.	USABLE ON CODE
51 -	NO NO.	WALL FRAME ASSEMBLY- 1 BATTERY	NP	
- 1	5236966	. JUMPER ASM-GRN/YEL 10 IN. 10AWG 1 LUG EA FOR COMPONENT PARTS SEE FIG. 58-34A	AR	
- 2	11598	. NUT,PLAIN-HEX 10-32 X 3/8 FL W	ATT PT	
- 3	56079	. WASHER,LOCK-EXT T .195 ID .410 OD	ATT PT	
- 4	5781844	. SCREEN	AR	
- 5	5713510	. BOOTSTRAP SUPPLY ASSEMBLY	AR	
- 6	34512	FOR DETAIL BREAKDOWN SEE FIGURE 52 . SCREW,BIND.HD 8-32 X .375 LG	ATT PT	
- 7	5759071	. JUMPER ASM	AR	
- 8	32042	FOR COMPONENT PARTS SEE FIG. 59-37A . SCREW, MACH BIND. HD 10-32 X 3/8 LG.	ATT PT	
- 9	56079	. WASHER,LOCK-EXT T .195 ID .410 OD	ATT PT	
- 10	5713590	. POWER SENSE AND BATTERY CHARGER ASSEMBLY FOR DETAIL BREAKDOWN SEE FIGURE 53	AR	
- 11	32042	. SCREW, MACH BIND. HD 10-32 X 3/8 LG.	ATT PT	
- 12	5759216	. JUMPER ASM	AR	
- 13	32042	FOR COMPONENT PARTS SEE FIG. 59-37A . SCREW, MACH BIND. HD 10-32 X 3/8 LG.	ATT PT	
- 14	56079	. WASHER,LOCK-EXT T .195 ID .410 OD	ATT PT	
- 15	5713558	. BATTERY PACKAGE ASM- 25 AMP SERVICE	AR	
- 16	32042	FOR DETAIL BREAKDOWN SEE FIGURE 55 . SCREW, MACH BIND. HD 10-32 X 3/8 LG.	ATT PT	
- 17	5781306	. FRAME ASM-WALL	AR	
- 18	5726736	. . BRACKET-MTG	1	
- 19	32042	. . SCREW, MACH BIND. HD 10-32 X 3/8 LG.	8	
- 20	45690	. . WASHER, FL - NO.10 X 7/16 OD X 1/32 THK	16	
- 21	9092	. . WASHER-LOCK,SPLIT RING, .194 ID .337OD	16	
- 22	5722125	. . CLAMP-CABLE	36	
- 23	438590	. . SCREW, MACH-UNDRCT BIND HD 8-32 X 1 3/4	72	
- 24	5722299	. . PLATE	18	
- 25	4636	. . SCREW,MACH-FL CSK HD 8-32 X 3/8 LG	36	
- 26	5240500	. . STRAP	2	
- 27	32042	. . SCREW, MACH BIND. HD 10-32 X 3/8 LG.	ATT PT	
- 28	56079	. . WASHER,LOCK-EXT T .195 ID .410 OD	ATT PT	
- 29	513669	. . STRIKE-FRICTION LATCH	8	
- 30	10170	. . SCREW,MACH-BIND,HD 6-32 X 1/4 LG	ATT PT	
- 31	5781351	. . FRAME-WALL	16	
			1	

FOR PARTS
NOT SHOWN
SEE FIG. 51

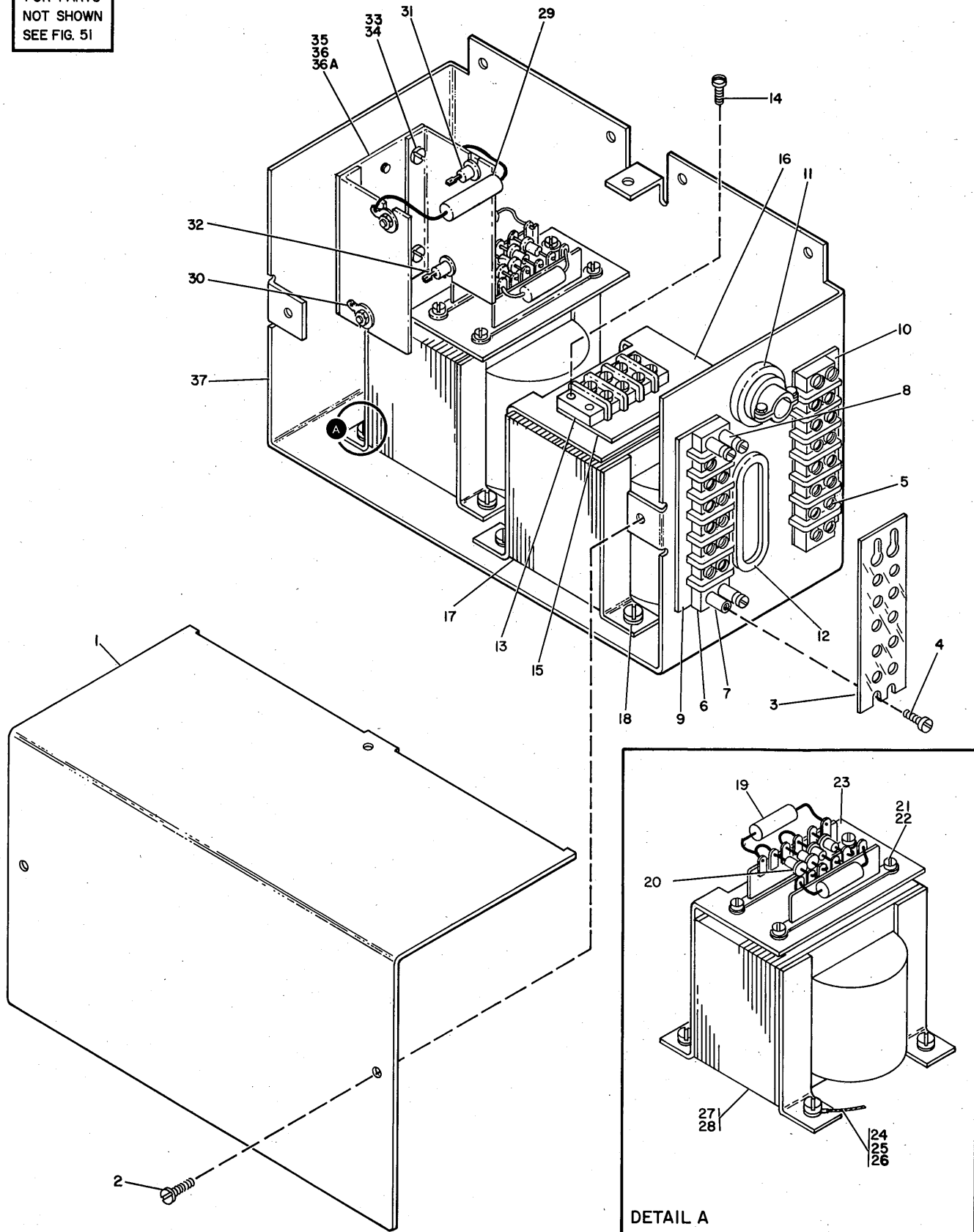

FIGURE 52. BOOTSTRAP SUPPLY ASSEMBLY.

LIST 52. BOOTSTRAP SUPPLY ASSEMBLY

FIGURE- INDEX NUMBER	PART NUMBER	DESCRIPTION				UNITS PER ASM.	USABLE ON CODE
		1	2	3	4		
52 -	5713510	BOOTSTRAP SUPPLY ASSEMBLY FOR NEXT HIGHER ASM, SEE FIGURE 51-5				REF	
- 1	5713515	• COVER				1	
- 2	10170	• SCREW, MACH-BIND HD 6-32 X 1/4 LG				3	
- 3	187479	• SHIELD TERMINAL BLOCK				2	
- 4	210984	• SCREW, RD HD MACH-6-32 X .250 LG				2	
- 5	334910	• TERMINAL-RING, 14-16 AWG, #6 HOLE, INS				1	
- 6	317232	• TERMINAL BOARD- 6 DBL SCREW TERMINALS				2	
- 7	210883	• STUD-SHIELD MTG, TAPPED, NO. 6-32				2	
- 8	210884	• STUD-SHIELD MTG, NO. 6-32				6	
- 9	589714	• STRIP-MARKER				1	
- 10	589715	• STRIP-MARKER				1	
- 11	151598	• CLAMP-CABLE				1	
- 12	364707	• CHANNEL				AR	
- 13	323841	• TERMINAL BOARD- 3 DBL SCREW TERMINALS				1	
- 14	322550	• SCREW, MACH, BIND HD- 6-32 X .5 LG				4	
- 15	323681	• MARKER STRIP- 3 POS NOS. 1 THRU 3				1	
- 16	5713514	• BRACKET, TERMINAL BOARD				1	
- 17	5713501	• TRANSFORMER				1	
- 18	58207	• SCREW, MACH-UNDRCT BIND HD 8-32 X 1/4 LG				1	
- 19	369849	• CAPACITOR				2	
- 20	316247	• SEMICONDUCTOR DEVICE, DIODE-TYPE C1				4	
- 21	317157	• STRIP-TERMINAL				2	
- 22	251970	• SCREW-MACH BD. HD. 4-40 X 1/4 LG				4	
- 23	5719775	• BRACKET				1	
- 24	5759177	• JUMPER ASSEMBLY				2	
- 25	55918	• SCREW, MACH-BIND HD 10-32 X 5/8 LG				1	
- 26	56079	• WASHER, LOCK-EXT T .195 ID .410 OD				1	
- 27	5214119	• TRANSFORMER				1	
- 28	10170	• SCREW, MACH-BIND HD 6-32 X 1/4 LG				4	
- 29	369849	• CAPACITOR				2	
- 30	316996	• TERMINAL, LUG-NONINS 9AWG NO. 8 MTG HOLE				4	
- 31	598355	• RECTIFIER, SILICON				2	
- 32	598353	• SEMICONDUCTOR DEVICE, DIO- 100V 10 AMP				2	
- 33	5719777	• HEATSINK				2	
- 34	438566	• SCREW, MACH-BIND HD 6-32 X .125 LG				4	
- 35	5719776	• BLOCK-TERMINAL				1	
- 36	81693	• SCREW, MACH-BIND HD 6-32 X 3/8 LG				2	
- 36A	333082	• SPACER				2	
- 37	5713513	• CHASSIS				1	

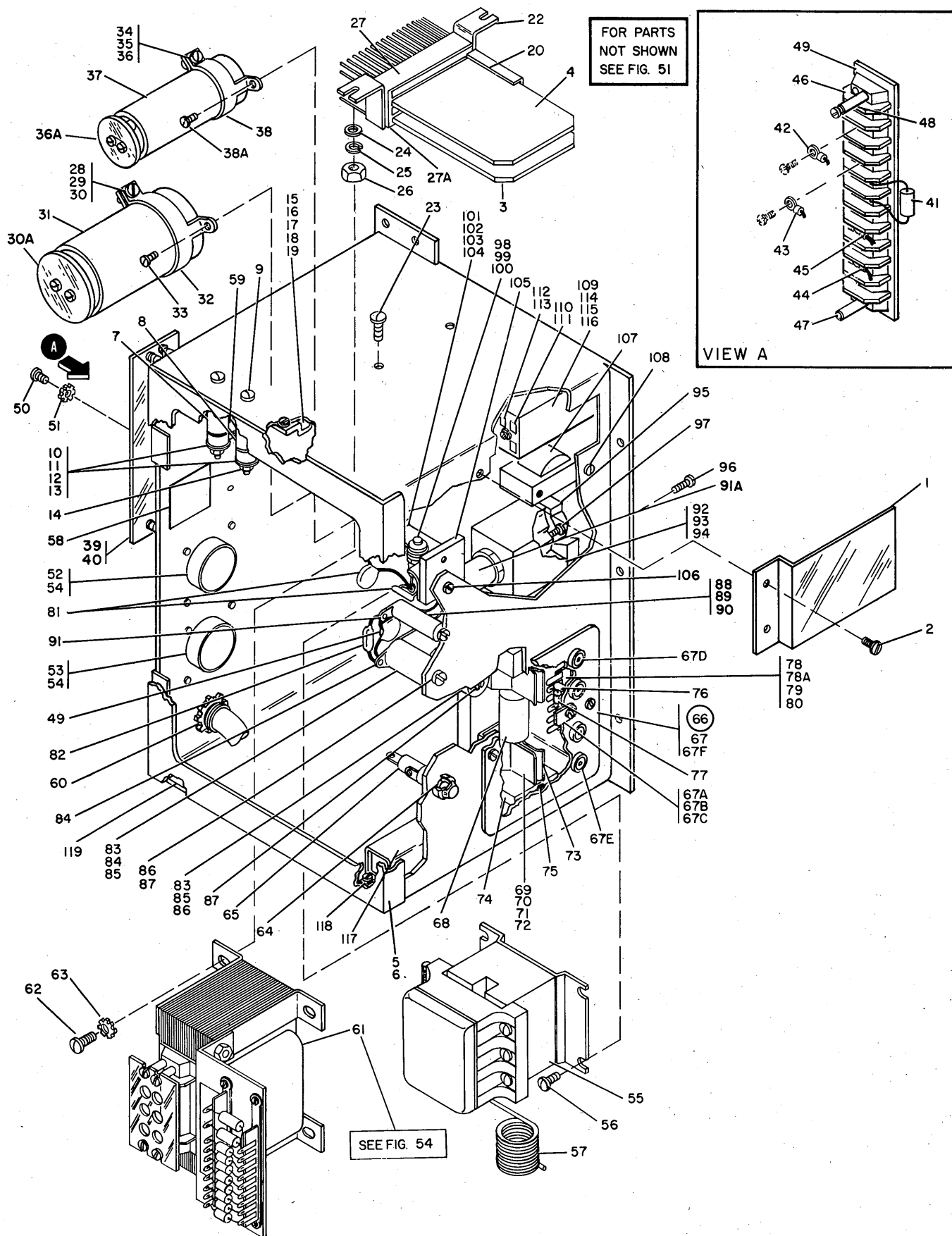

FIGURE 53. POWER SENSE AND BATTERY CHARGER ASSEMBLY.

LIST 53. POWER SENSE AND BATTERY CHARGER ASSEMBLY

FIGURE- INDEX NUMBER	PART NUMBER	DESCRIPTION	UNITS PER ASM.	USABLE ON CODE
53 -	5713590	POWER SENSE AND BATTERY CHARGER ASSEMBLY FOR NEXT HIGHER ASM,SEE FIGURE 51-10	REF	
- 1	5713564	. BRACKET	1	
- 2	10170	. SCREW,MACH-BIND HD 6-32 X 1/4 LG	2	
- 3	374863	. CARD ASSEMBLY	1	
- 4	374862	. CARD ASSEMBLY	1	
- 5	5713577	. COVER	1	
- 6	236849	. SCREW,MACH-BIND HD 10-32 X 0.250 LG	1	ATT PT
- 7	507142	. RESISTOR- 100 OHMS 25W	1	
- 8	301821	. RESISTOR	1	
- 9	45259	. SCREW,MACHINE	2	ATT PT
- 10	442958	. INSULATOR,WASH- 7/16 ID 3/4 OD 1/32 THK	4	ATT PT
- 11	507144	. WASHER-CENTERING 0.173 ID X 5/8 OD	4	ATT PT
- 12	110029	. WASHER,FL-NO 8 X 5/8 OD X 1/16 THK	2	ATT PT
- 13	1090873	. WASHER,LOCK,SPLIT RING- .168 ID, .296 OD	2	ATT PT
- 14	257189	. NUT,HEX- 8-32	2	ATT PT
- 15	2102364	. CLAMP,LOOP- 0.220 ID 0.170 DIA MTG HOLE	1	
- 16	35739	. SCREW,MACH-BIND HD 6-32 X 15/16 LG	1	ATT PT
- 17	257986	. WASHER,FLAT NO. 6	1	ATT PT
- 18	56722	. WASHER,LOCK-EXT TEETH NO. 6	1	ATT PT
- 19	257187	. NUT,PLAIN,HEX- 6-32 X 3/8 FL W	1	ATT PT
- 20	5713640	. SPACER	1	
- 22	473530	. BRACKET	1	
- 23	38447	. SCREW,MACH-FH 6-32 X 5/8 LG	2	ATT PT
- 24	257986	. WASHER,FLAT NO. 6	2	ATT PT
- 25	6364	. WASHER,LOCK-SPLIT NO. 6 X 1/4 OD	2	ATT PT
- 26	257187	. NUT,PLAIN,HEX- 6-32 X 3/8 FL W	2	ATT PT
- 27	216076	. TERMINAL BLOCK AND CONTACT ASSEMBLY	2	
- 27A	473547	. SPACER,1 X 2 3/8 IN .12 IN THICK	1	
- 28	438551	. SCREW,MACH-BIND HD 4-40 X 5/8 LG	1	
- 29	257984	. WASHER,LOCK-SPLIT 1/8 ID X 13/64 OD	1	
- 30	37913	. NUT-HEX 4-40 X .250 ID	1	
- 30A	362206	. COVER, CAPACITOR	1	
- 31	208235	. CAPACITOR,ELECT. 5500 MFD P 100 M 10 PCT	1	
- 32	320456	. BRACKET-CAPACITOR MOUNTING	1	
- 33	55726	. SCREW,MACH-BIND HD 6-32 X .188 LG	3	ATT PT
- 34	438551	. SCREW,MACH-BIND HD 4-40 X 5/8 LG	1	
- 35	257984	. WASHER,LOCK-SPLIT 1/8 ID X 13/64 OD	1	
- 36	37913	. NUT-HEX 4-40 X .250 ID	1	
- 36A	5261296	. COVER-CAPACITOR	1	
- 37	208227	. CAPACITOR, ELECTROLYTIC-1000 UF 45VDC	1	
- 38	445304	. CLAMP	1	
- 38A	10170	. SCREW,MACH-BIND HD 6-32 X 1/4 LG	2	ATT PT
- 39	191481	. SHIELD, TERMINAL BLOCK	1	
- 40	10170	. SCREW,MACH-BIND HD 6-32 X 1/4 LG	1	ATT PT
- 41	5708939	. CAPACITOR ASM- 0.100MFD P/M 10% 100VDC	1	
- 42	360370	. TERMINAL-WIRE RING TONGUE	1	
- 43	92784	. TERMINAL-RING,18-20 AWG #8 HOLE, INS	1	
- 44	334768	. TERMINAL,RING-16-22 AWG 1/4 MTG HOLE	6	
- 45	335327	. TERMINAL,LUG- SCREW SIZES 8 THRU 10	2	
- 46	323839	. TERMINAL BOARD- 12 DBL SCREW TERMINALS	1	
- 47	210883	. STUD-SHIELD MTG,TAPPED,NO. 6-32	1	ATT PT
- 48	210884	. STUD-SHIELD MTG,NO. 6-32	3	ATT PT
- 49	5213022	. MARKER STRIP- 12 POSITION	1	
- 50	35739	. SCREW,MACH-BIND HD 6-32 X 15/16 LG	1	
- 51	56722	. WASHER,LOCK-EXT TEETH NO. 6	1	
- 52	5713572	. CONNECTOR,RECEPTACLE,ELECTRICAL	1	
- 53	5713571	. CONNECTOR,RECEPTACLE,ELECTRICAL	1	
- 54	10170	. SCREW,MACH-BIND HD 6-32 X 1/4 LG	8	ATT PT
- 55	5276703	. RELAY-24 VDC COIL	1	
- 56	221790	. SCREW,MACH-BIND HD 8-32 X 3/16 LG	3	ATT PT
- 57	5713547	. SPRING,HELICAL,TORSION	1	
- 58	5713563	. LABEL	1	
- 59	123075	. GRUMMET,ROB-FLR 13/16 HOLE X 1/8 PNL	1	
- 60	151598	. CLAMP-CABLE	1	
- 61	5713641	. TRANSFORMER SUB ASSEMBLY FOR DETAIL BREAKDOWN,SEE FIGURE 54.	1	
- 62	236849	. SCREW,MACH-BIND HD 10-32 X 0.250 LG	4	ATT PT
- 63	56079	. WASHER,LOCK-EXT T .195 ID .410 OD	4	ATT PT
- 64	6324	. FUSE-CTG 3 AMP	1	
- 65	179946	. HOLDER-FUSE	1	

LIST 53. POWER SENSE AND BATTERY CHARGER ASSEMBLY

FIGURE- INDEX NUMBER	PART NUMBER	DESCRIPTION	UNITS PER ASM.	USABLE ON CODE
53 -	66	5789831		
- 66	5789831	. BRACKET	1	
- 67	186759	. SCREW,MACH-BIND HD 8-32 X 5/16 LG	2	ATT PT
- 67A	5213276	. . CLAMP-CABLE	1	
- 67B	34512	. . SCREW,BIND.HD 8-32 X .375 LG	1	ATT PT
- 67C	257189	. . NUT,HEX- 8-32	1	ATT PT
- 67D	322599	. . JACK,TIP	2	
- 67E	322609	. . JACK,TIP-RED	2	
- 67F	5713639	. . COVER, FUSE	1	
- 68	5261451	. FUSE,CARTRIDGE-50 AMP 250V	1	
- 69	5703214	. PLATE,LOCKING-FUSE	2	
- 70	5703213	. STUD-FUSE BLOCK MTG	2	ATT PT
- 71	3550	. WASHER,FL- 1/4 X 9/16 OD X 0.050 THK	2	ATT PT
- 72	3960	. NUT,PLAIN,HEX- 1/4-20 X 7/16 FL W	2	ATT PT
- 73	5703220	. CONTACT	2	
- 74	5713638	. BRACKET	1	
- 75	25891	. SCREW,MACH-FL CSK HD 10-32 X 0.500 LG	2	ATT PT
- 76	528403	. LAMP,GLOW	1	
- 77	216475	. RESISTOR,FXD,COMP-20K P/M 5% 1/4W	1	
- 78	317157	. STRIP-TERMINAL	1	
- 78A	5213276	. CLAMP	2	
- 79	55726	. SCREW,MACH-BIND HD 6-32 X .188 LG	2	ATT PT
- 80	6364	. WASHER,LOCK-SPLIT NO. 6 X 1/4 OD	2	ATT PT
- 81	317262	. CAPACITOR,FXD,CER- 0.01 UF P80M20% 450V	3	
- 82	132773	. RESISTOR,FIXED	1	
- 83	438623	. SCREW,MACH-BIND HD 1/4-20 X 5/8 LG	2	
- 84	15484	. LUG	1	
- 85	5713635	. STANDOFF	2	
- 86	186036	. SCREW,MACH-FH 1/4-20 X 1/2 LG	2	ATT PT
- 87	3550	. WASHER,FL- 1/4 X 9/16 OD X 0.050 THK	2	ATT PT
- 88	5713634	. STANDOFF	1	
- 89	35739	. SCREW,MACH-BIND HD 6-32 X 15/16 LG	2	ATT PT
- 90	257986	. WASHER,FLAT NO. 6	1	ATT PT
- 91	317158	. TERMINAL,LUG	1	
- 91A	5261457	. SEMICONDUCTOR DEVICE-CONTROLLED RECT	1	
- 92	5713632	. BLOCK	1	
- 93	38368	. SCREW,MACHINE-FIL H 8-32 X 0.438 LG	1	ATT PT
- 94	22478	. WASHER,FL- 0.170 ID 0.375 OD 0.32 THK	1	ATT PT
- 95	5713633	. PLATE,MOUNTING	1	
- 96	186758	. SCREW,MACH-BIND HD 8-32 X 0.438	2	ATT PT
- 97	38368	. SCREW,MACHINE-FIL H 8-32 X 0.438 LG	2	ATT PT
- 98	5214104	. SEMICONDUCTOR- 11.5A 400V	1	
- 99	160017	. NUT,PLAIN,HEX- 1/4-28 X 7/16 FL W	1	ATT PT
- 100	3550	. WASHER,FL- 1/4 X 9/16 OD X 0.050 THK	1	ATT PT
- 101	35739	. SCREW,MACH-BIND HD 6-32 X 15/16 LG	1	
- 102	257986	. WASHER,FLAT NO. 6	1	
- 103	5713636	. BRACKET	1	
- 104	186759	. SCREW,MACH-BIND HD 8-32 X 5/16 LG	2	ATT PT
- 105	5713637	. BRACKET	1	
- 106	186759	. SCREW,MACH-BIND HD 8-32 X 5/16 LG	2	ATT PT
- 107	5713519	. CHOKE	1	
- 108	10170	. SCREW,MACH-BIND HD 6-32 X 1/4 LG	2	ATT PT
- 109	5364197	. GROUND-RELAY	2	
- 110	5276326	. RELAY, 2 PDT- 5 AMP 24 VDC	2	
- 111	5364198	. RETAINER	2	
- 112	5364276	. SOCKET	2	
- 113	5719778	. BRACKET	1	
- 114	236550	. SCREW,MACH-BIND HD 4-40 X 0.375 LG	2	ATT PT
- 115	338169	. WASHER,LOCK-EXT TEETH NO. 4 X .260 OD	2	ATT PT
- 116	37913	. NUT-HEX 4-40 X .250 ID	2	ATT PT
- 117	98865	. CAPACITOR	1	
- 118	55726	. SCREW,MACH-BIND HD 6-32 X .188 LG	2	
- 119	5713576	. HOUSING	1	

FOR PARTS
NOT SHOWN
SEE FIG. 53

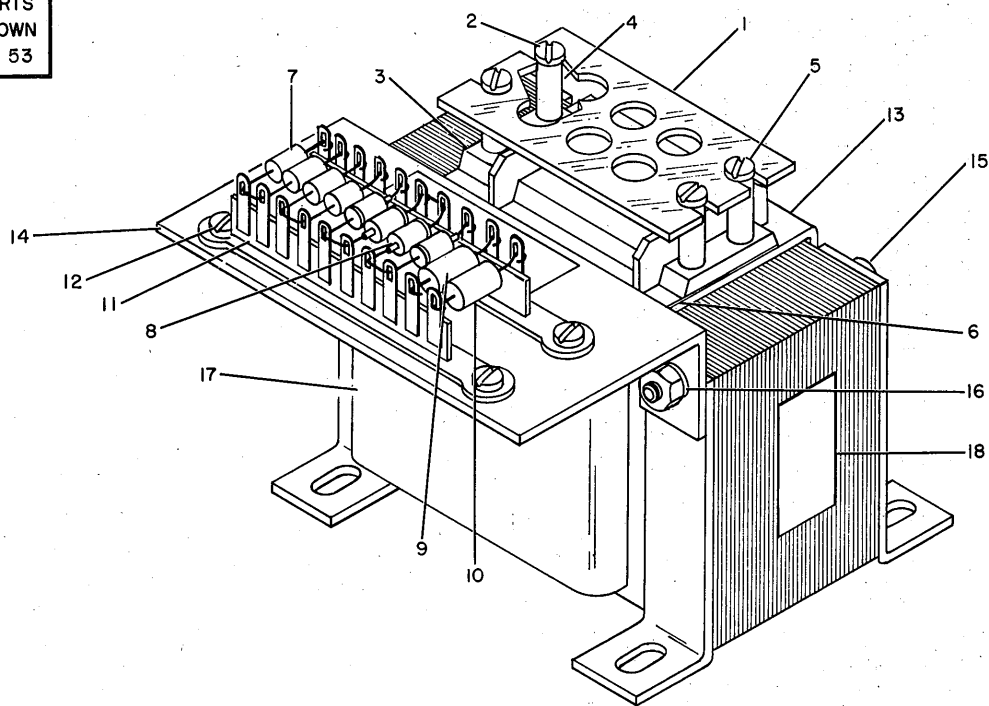

FIGURE 54. TRANSFORMER SUB ASSEMBLY.

LIST 54. TRANSFORMER SUB ASSEMBLY

FIGURE- INDEX NUMBER	PART NUMBER	DESCRIPTION				UNITS PER ASM.	USABLE ON CODE
		1	2	3	4		
54 -	5713641	TRANSFORMER SUB ASSEMBLY FOR NEXT HIGHER ASM, SEE FIGURE 53-61				REF	
- 1	192589	. SHIELD				1	
- 2	210984	. SCREW, RD HD MACH-6-32 X .250 LG ATT PT				1	
- 3	317132	. TERMINAL BOARD- 3 DBL SCREW TERMINALS				1	
- 4	210985	. STUD,EXT-INT 6-32 EXT 8-32 X 0.900 LG OA ATT PT				1	
- 5	210986	. STUD-SHIELD MOUNTING ATT PT				3	
- 6	322270	. STRIP, MARKER				1	
- 7	2111232	. SEMICONDUCTOR DEVICE,DIODE-TYPE AM				4	
- 8	5713517	. RECTIFIER				4	
- 9	317105	. RESISTOR				1	
- 10	132812	. RESISTOR				1	
- 11	317218	. TERMINAL BOARD- 10 SOLDER LUG TERM				2	
- 12	438548	. SCREW,MACH-BIND HD 4-40 X 3/16 LG ATT PT				4	
- 13	5713631	. BRACKET				1	
- 14	5713630	. BRACKET				1	
- 15	438548	. SCREW,MACH-BIND HD 4-40 X 3/16 LG ATT PT				2	
- 16	1090873	. WASHER,LOCK,SPLIT RING- .168 ID, .296 OD ATT PT				2	
- 17	5213499	. TRANSFORMER				1	
- 18	317296	. LABEL-NUMBERING L TO R 1 THRU 33				1	

FOR PARTS
NOT SHOWN
SEE FIG. 51

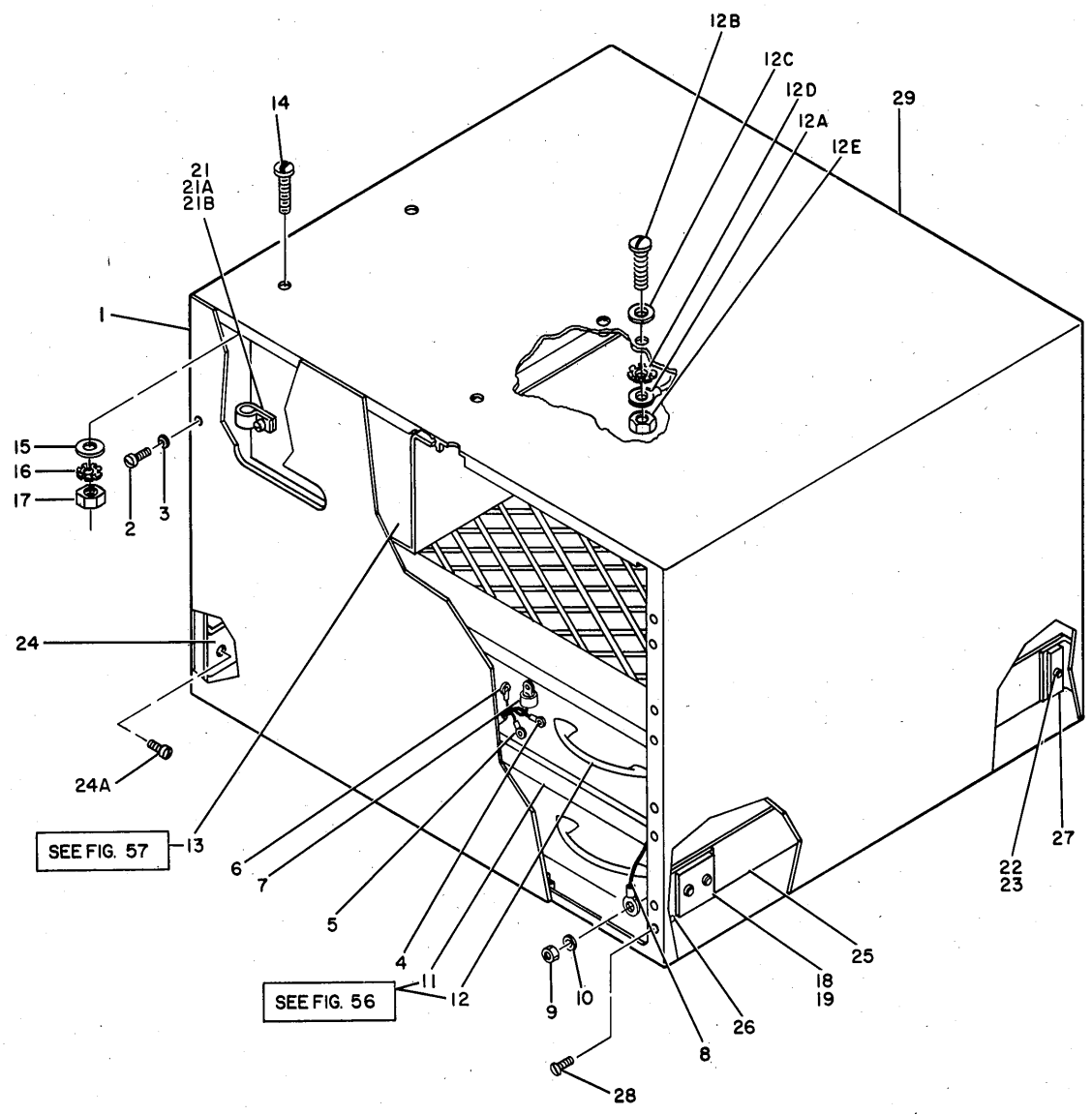

FIGURE 55. 25 AMP SERVICE BATTERY PACKAGE ASSEMBLY.

LIST 55. 25 AMP SERVICE BATTERY PACKAGE ASSEMBLY

FIGURE- INDEX NUMBER	PART NUMBER	DESCRIPTION				UNITS PER ASM.	USABLE ON CODE
		1	2	3	4		
55 -	5713558	BATTERY PACKAGE ASM- 25 AMP SERVICE FOR NEXT HIGHER ASM,SEE FIGURE 51-15				REF	
- 1	5713531	• COVER				1	
- 2	81693	• SCREW,MACH-BIND HD 6-32 X 3/8 LG		ATT PT	2		
- 3	1074145	• WASHER,FLAT-NO. 6		ATT PT	2		
- 4	334921	• TERMINAL-RING,18-22 AWG,#6 HOLE,INS				4	
- 5	186968	• TERMINAL-RING,10-12 AWG,#8 HOLE,INS				4	
- 6	2101326	• TERMINAL,RING-12-10 AWG				4	
- 7	335327	• TERMINAL,LUG- SCREW SIZES 8 THRU 10				4	
- 8	5713556	• LEAD,ELECTRICAL				2	
- 9	324948	• NUT,HEX DOUBLE CHAMFER		ATT PT	3		
- 10	1090240	• WASHER,FL- 0.218 ID X 3/8 OD X 1/32 THK		ATT PT	3		
- 11	5713548	• TRAY ASSEMBLY, 13 BATTERY HOOKUP FOR DETAIL BREAKDOWN,SEE FIGURE 56				1	
- 12	5713549	• TRAY ASSEMBLY, 12 BATTERY HOOKUP FOR DETAIL BREAKDOWN,SEE FIGURE 56				1	
- 12A	5713556	• LEAD,ELECTRICAL				1	
- 12B	25627	• SCREW-BD. HD 8-32 X .500 LG		ATT PT	AR		
- 12C	22478	• WASHER,FL- 0.170 ID 0.375 OD 0.32 THK		ATT PT	AR		
- 12D	55901	• WASHER,LOCK-EXT TEETH NO. 8 X 0.381 OD		ATT PT	AR		
- 12E	257189	• NUT,HEX- 8-32		ATT PT	AR		
- 13	5713611	• BATTERY PACKAGE ASSEMBLY FOR DETAIL BREAKDOWN,SEE FIGURE 57				1	
- 14	25627	• SCREW-BD. HD 8-32 X .500 LG		ATT PT	4		
- 15	22478	• WASHER,FL- 0.170 ID 0.375 OD 0.32 THK		ATT PT	4		
- 16	55901	• WASHER,LOCK-EXT TEETH NO. 8 X 0.381 OD		ATT PT	4		
- 17	257189	• NUT,HEX- 8-32		ATT PT	4		
- 18	5713542	• PLATE				12	
- 19	5713568	• SCREW				12	
- 21	5213306	• CLIP				1	
- 21A	322550	• SCREW,MACH,BIND HD- 6-32 X .5 LG		ATT PT	1		
- 21B	22478	• WASHER,FL- 0.170 ID 0.375 OD 0.32 THK		ATT PT	2		
- 22	5713543	• NUT,WELD				4	
- 23	5713568	• SCREW				4	
- 24	5713536	• SLIDE ASSEMBLY				2	
- 24A	124226	• SCREW, CAP, SOC HD 8-32 X 0.162 LG		ATT PT	2		
- 25	5786802	• SLIDE				2	
- 26	5713540	• BRACKET,ANGLE				4	
- 27	5713541	• BRACKET,ANGLE				4	
- 28	38443	• SCREW,MACH-FL CSK HD 6-32 X 5/16 LG		ATT PT	16		
- 29	5713550	• TRAY ASSEMBLY-13 BATTERY HOOK-UP				1	

FOR PARTS
NOT SHOWN
SEE FIG. 55

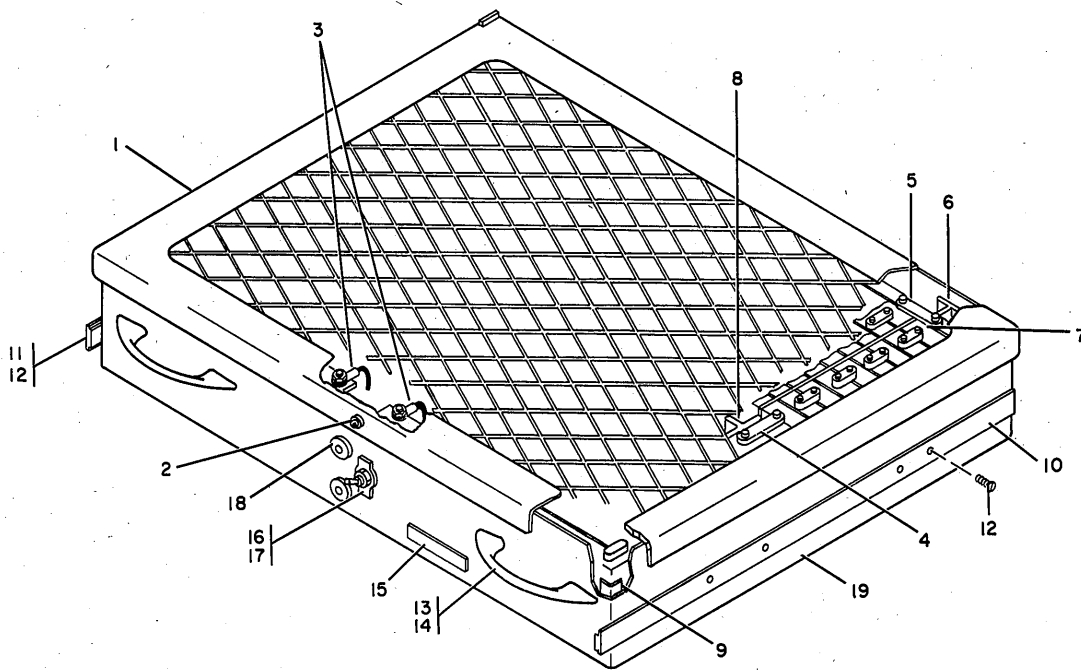

FIGURE 56. 12 AND 13 BATTERY TRAY ASSEMBLY.

LIST 56. 12 AND 13 BATTERY TRAY ASSEMBLY

FIGURE- INDEX NUMBER	PART NUMBER	1 2 3 4	DESCRIPTION	UNITS PER ASM.	USABLE ON CODE
56 -	5713548		TRAY ASSEMBLY, 13 BATTERY HOOKUP FOR NEXT HIGHER ASM,SEE FIGURE 55-11	REF	
-	5713549		TRAY ASSEMBLY, 12 BATTERY HOOKUP FOR NEXT HIGHER ASM,SEE FIGURE 55-12	REF	
- 1	5713645		. COVER	1	
- 2	5713562		. SCREW ATT PT	1	
- 3	5713553		. LEAD,ELECTRICAL	AR	
- 4	5713545		. BUSS BAR	AR	
- 5	5713544		. BUSS BAR	AR	
- 6	5713538		. BRACKET	12	
- 7	5713500+		. BATTERY	13	
- 8	5713537		. BRACKET	6	
- 9	5713539		. BRACKET	6	
- 10	5786801		. SLIDE	1	
- 11	5713535		. SLIDE	1	
- 12	5713568		. SCREW ATT PT	8	
- 13	5713561		. HANDLE	2	
- 14	58207		. SCREW,MACH-UNDRCT BIND HD 8-32 X 1/4 LG ATT PT	4	
- 15	5313943		. LABEL	1	
- 16	109872		. SWITCH, TOGGLE DPST	1	
- 17	5713578		. DIAL	1	
- 18	450821		. GROMMET,5/16 I.O. X 13/16 O.O.X 5/16 THK	2	
- 19	5713532		. COVER	1	

FOR PARTS
NOT SHOWN
SEE FIG. 55

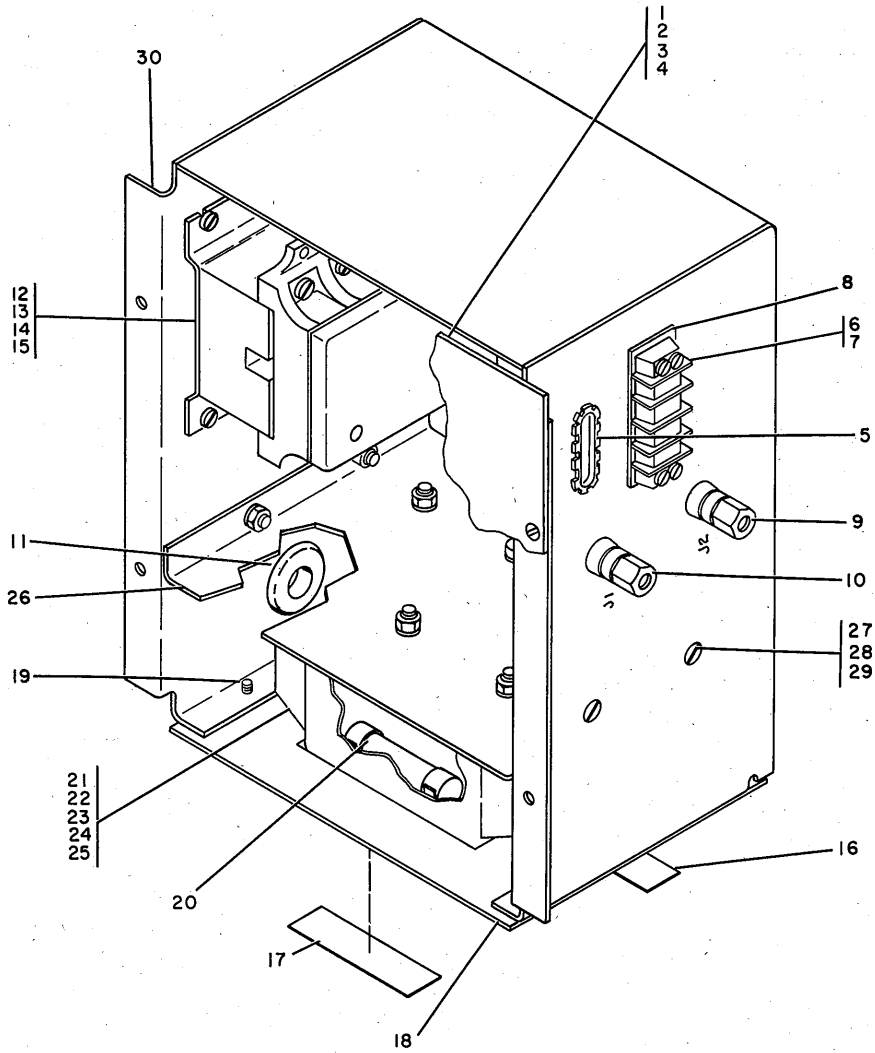

FIGURE 57. BATTERY PACKAGE ASSEMBLY.

LIST 57. BATTERY PACKAGE ASSEMBLY

FIGURE- INDEX NUMBER	PART NUMBER	DESCRIPTION				UNITS PER ASM.	USABLE ON CODE
		1	2	3	4		
57 -	5713611	BATTERY PACKAGE ASSEMBLY FOR NEXT HIGHER ASM, SEE FIGURE 55-13				REF	
- 1	5713615	. PLATE				1	
- 2	38443	. SCREW, MACH-FL CSK HD 6-32 X 5/16 LG				2	
- 3	56722	. WASHER, LOCK-EXT TEETH NO. 6				2	
- 4	257187	. NUT, PLAIN, HEX- 6-32 X 3/8 FL W				2	
- 5	730432	. GROMMET, CATERPILLAR				1	
- 6	323838	. BLOCK				1	
- 7	81693	. SCREW, MACH-BIND HD 6-32 X 3/8 LG				4	
- 8	515620	. INSULATOR				1	
- 9	320570	. POST, BINDING-BLACK				1	
- 10	331065	. POST, BINDING				1	
- 11	512663	. GROMMET, RUB-FOR 7/8 HOLE X 1/8 PNL				2	
- 12	5276703	. RELAY-24 VDC COIL				1	
- 13	322550	. SCREW, MACH, BIND HD- 6-32 X .5 LG				2	
- 14	56722	. WASHER, LOCK-EXT TEETH NO. 6				2	
- 15	257187	. NUT, PLAIN, HEX- 6-32 X 3/8 FL W				2	
- 16	5789779	. LABEL				1	
- 17	5713563	. LABEL				1	
- 18	5713613	. COVER				1	
- 19	38235	. SCREW, MACH-BIND HD 6-32 X 0.312 LG				3	
- 20	5789803	. FUSE CARTRIDGE				2	
- 21	5261373	. PULLOUT-FUSED				1	
- 22	438567	. SCREW, MACH-UNDRCT BIND HD 6-32 X 1 LG				2	
- 23	438570	. SCREW, MACH-BIND HD 6-32 X 1-1/2 LG				2	
- 24	56722	. WASHER, LOCK-EXT TEETH NO. 6				4	
- 25	257187	. NUT, PLAIN, HEX- 6-32 X 3/8 FL W				4	
- 26	5713614	. BRACKET				1	
- 27	322550	. SCREW, MACH, BIND HD- 6-32 X .5 LG				6	
- 28	56722	. WASHER, LOCK-EXT TEETH NO. 6				6	
- 29	257187	. NUT, PLAIN, HEX- 6-32 X 3/8 FL W				6	
- 30	5713612	. CHASSIS				1	

LIST 58. 7201 CABLE ASSEMBLIES

FIGURE- INDEX NUMBER	PART NUMBER	DESCRIPTION	UNITS PER ASM.	USABLE ON CODE
		1 2 3 4		
58 - - 1	NO NO. 5276333	7201 CABLE ASSEMBLIES • CABLE ASM,CPU PWR WALL-I/C OUTPUT 140V FOR COMPONENT PARTS SEE FIG. 59-5,-36A, -36B,-36C	NP AR	
- 2	5276334	• CABLE ASM,PWR I/C OUTPUT- 140V FOR COMPONENT PARTS SEE FIG. 59-5,-36A, -36B,-36C	AR	
- 3	5276335	• CABLE ASM,PWR I/C OUTPUT- 140V FOR COMPONENT PARTS SEE FIG. 59-5,-36A, -36B,-36C	AR	
- 4	5276336	• CABLE ASM,PWR I/C INPUT- 140V FOR COMPONENT PARTS SEE FIG. 59-5,-36A, -36B,-36C	AR	
- 5	5276490	• CABLE ASM,CPU PWR WALL-I/C INPUT FOR COMPONENT PARTS SEE FIG. 59-5A,-36A, -36F,-45	AR	
- 6	5276491	• CABLE ASM,LINE CORD FOR COMPONENT PARTS SEE FIG. 59-33,-34A, -34B,-36	AR	
- 7	5400736	• CABLE ASM,PWR DIST.-TB2 TO TB4 36.75 IN.	AR	
- 8	5400737	• CABLE ASM,PWR DIST.-TB2 TO TB4 35 IN.	AR	
- 9	5400738	• CABLE ASM,PWR DIST.-TB2 TO TB4 28.75 IN.	AR	
- 10	5400739	• CABLE ASM,PWR DIST.-TB2 TO TB4 30 IN.	AR	
- 11	5400740	• CABLE ASM,PWR DIST.-TB2 TO TB4 28.50 IN.	AR	
- 12	5400741	• CABLE ASM,PWR DIST.-TB2 TO TB1 6 IN.	AR	
- 13	5400742	• CABLE ASM,PWR DIST.- TB1 TO TB2 8.75 IN	AR	
- 14	5400743	• CABLE ASM,PWR DIST.- TB1 TO TB2 14 IN.	AR	
- 15	5400744	• CABLE ASM,PWR DIST.- TB1 TO TB2 16 IN. FOR COMPONENT PARTS SEE FIG. 59-8,-9 AND -36A	AR	
- 16	5722091	• CABLE ASM,DYN RELOCATION PWR-C/I OUTPUT	AR	
- 17	5723114	• CABLE ASM,CPU CONVENIENCE OUTLET	AR	
- 18	5781343	• CABLE ASM,THERMAL-GATES 02A,02C,02E FOR COMPONENT PARTS SEE FIG. 59-1,-4A, -18,-19A,-22A,-26,-27,-28 AND -31A	AR	
- 19	5781344	• CABLE ASM,DAT PWR CONTROL- 02G-GATE 02L	AR	
- 20	5781345	• CABLE ASM,DAT GATE PWR DISTRIBUTION	AR	
- 21	5781346	• CABLE ASM,CONSOLE PWR-PRIM PWR/RT I/O FOR COMPONENT PARTS SEE FIG. 59-16,-16A, -36B,-36C,-37A,-39	AR	
- 22	5781348	• CABLE SET,PWR TO CE GATES-UPPER BUS FOR COMPONENT PARTS SEE FIG. 59-17, -32,-34,-36A	AR	
- 23	5781349	• CABLE SET,PWR TO CE GATES-LOWER BUS FOR COMPONENT PARTS SEE FIG. 59-17, -32,-34,-36A	AR	
- 24	5781436	• CABLE ASM,INTERNAL RIGHT POWER SUPPLY FOR COMPONENT PARTS SEE FIG. 59-16,-22, -34,-36C,-36E,-38	AR	
- 25	5781437	• CABLE ASM,LEFT I/O DISTRIBUTION FOR COMPONENT PARTS SEE FIG. 59-7,-16, -16A,-16F,-25,-25A,-34,-36B,-36C,-36E, -38	AR	
- 26	5781438	• CABLE ASM,INTERNAL LEFT POWER SUPPLY FOR COMPONENT PARTS SEE FIG. 59-16,-16A, -36B,-37A,-39	AR	
- 27	5781439	• CABLE ASM,09P2 TO DAT FRAME FOR COMPONENT PARTS SEE FIG. 59-36C, -40,-40A,-62,-63	AR	
- 28	5781450	• CABLE ASM,MARG CHK-GATES A,B,C AND E FOR COMPONENT PARTS SEE FIG. 59-16,-34	AR	
- 29	5781451	• CABLE ASM,POWER COLUMN 02G FOR COMPONENT PARTS SEE FIG. 59-16,-16A, -19A,-34,-36B,-36E,-37A	AR	
- 30	5781455	• CABLE ASM,PWR AND CNTL CE PNL/PWR WALL FOR COMPONENT PARTS SEE FIG. 59-1,-3A, -4,-10,-11,-12A,-13,-14,-15,-18,-18A, -19A,-19B,-22B,-23,-25,-26-26A,-29,-31D -34,-36B,-36C AND -36E	AR	
- 31	5781459	• CABLE ASM,CPU PANEL FOR COMPONENT PARTS SEE FIG. 59-4B,-10, -11,-16,-17,-30	AR	

LIST 58. 7201 CABLE ASSEMBLIES

FIGURE- INDEX NUMBER	PART NUMBER	DESCRIPTION				UNITS PER ASM.	USABLE ON CODE
58 - 32 - 33	5781479 5781483	<ul style="list-style-type: none"> . CABLE ASM,C/I BIAS AND INTERLOCK . CABLE ASM,FRAME 09/BATTERY CONTROL FOR COMPONENT PARTS SEE FIG. 59-2,-12, -16,-19A,-26B,-31C,-34,-34A,-36B,-36C, -36E,-39				AR AR	
- 34	5781484	<ul style="list-style-type: none"> . CABLE ASM,BATTERY FRAME 09- INTERNAL FOR COMPONENT PARTS SEE FIG. 59-16,-20, -34A,-36C,-39,-41				AR	
- 35	5781485	<ul style="list-style-type: none"> . CABLE ASM,PWR WALL-TB9/TB70/RELAY GATE FOR COMPONENT PARTS SEE FIG. 59-3,-7, -13,-14,-15,-16,-16A,-16B,-16C,-16D,-16E -18A,-21,-22,-22B,-25,-25A,-25B,-26A,-31 -31B,-31C,-34,-36B,-36C,-36E,-36F,-38, -43A,-44,-60,-61				AR	
- 36	5781488	<ul style="list-style-type: none"> . CABLE ASM,PRIMARY PWR BOX-AC FOR COMPONENT PARTS SEE FIG. 59-16,-34A, -36A				AR	
- 37	5781489	<ul style="list-style-type: none"> . CABLE ASM,PRIMARY PWR BOX-DC FOR COMPONENT PARTS SEE FIG. 59-16,-16A, -34A,-36A,-36B,-36C,-36D,-36E,-36F,-37,				AR	
- 38 - 39	5781490 5781491	<ul style="list-style-type: none"> . CABLE ASM,RELAY GATE OIB-INTERNAL . CABLE ASM,RELAY GATE INDICATORS/SWITCHES 				AR AR	

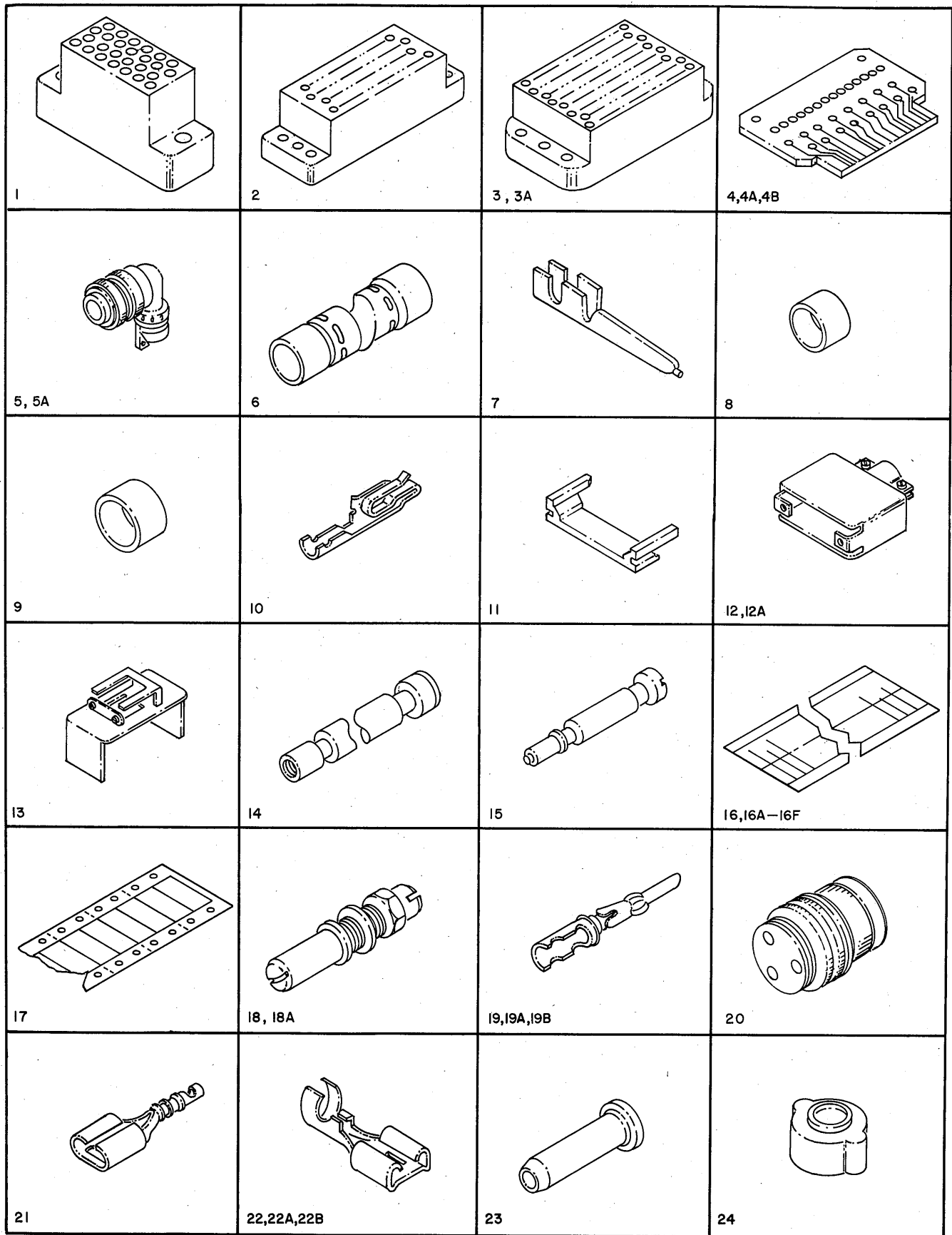

FIGURE 59. CABLE AND JUMPER ASSEMBLY COMPONENT PARTS. (SHEET 1 OF 3, INDEX NOS. 1-24)

LIST 59. CABLE AND JUMPER ASSEMBLY COMPONENT PARTS

FIGURE- INDEX NUMBER	PART NUMBER	DESCRIPTION 1 2 3 4	UNITS PER ASM.	USABLE ON CODE
59 -	NO NO.	CABLE AND JUMPER ASM, COMPONENT PARTS	NP	
- 1	2122838	. BLOCK, MALE- 26 POS MINIATURE CONNECTOR	AR	
- 2	2122257	. BLOCK, MALE- 34 POS MINIATURE CONNECTOR	AR	
- 3	2122625	. BLOCK, FEMALE- 104 POS MINIATURE CONN	AR	
- 3A	2122626	. BLOCK, MALE- 104 POS MINIATURE CONNECTOR	AR	
- 4	5800610	. CARD ASM-TERMINATOR	AR	
- 4A	5800667	. CARD ASM	AR	
- 4B	5803299	. CARD ASM-SWITCH CABLE PADDLE	AR	
- 5	5276474	. CONNECTOR, PLUG, ELEC-3 MALE CONTACTS	AR	
- 5A	5276475	. CONNECTOR, PLUG, ELEC-7 FEMALE CONTACTS	AR	
- 6	523176	. CONNECTOR, TWO WAY, WIRE SIZE 24-20	AR	
- 7	360433	. CONNECTOR, TAPER PIN-BARE WIRE CRIMP	AR	
- 8	350837	. CONNECTOR SHEATH-INNER	AR	
- 9	350836	. CONNECTOR SHEATH-OUTER	AR	
- 10	5362301	. CONTACT, LARGE SERPENT. 20-24AWG	AR	
- 11	811802	. GUIDE-CARD	AR	
- 12	2127864	. HOOD, 180 DEGREE 34 POS- 1 PIECE	AR	
- 12A	2127895	. HOOD, 180 DEG.- 26 POSITION 1 PC	AR	
- 13	2122627	. HOOD, 180 DEG.- 104 POSITION 2 PC	AR	
- 14	2122628	. JACK SOCKET-LONG SHIELD TYPE	AR	
- 15	2122629	. JACK, SCREW, HAND-LONG SHIELD TYPE	AR	
- 16	317296	. LABEL-NUMBERING L TO R 1 THRU 33	AR	
- 16A	317297	. LABEL-NUMBERING L TO R 34 THRU 66	AR	
- 16B	317298	. LABEL-NUMBERING L TO R 67 THRU 99	AR	
- 16C	317299	. LABEL-NUMBERING L TO R 100 THRU 124	AR	
- 16D	317300	. LABEL-NUMBERING L TO R 125 THRU 149	AR	
- 16E	334219	. LABEL-NUMBERING L TO R 150 THRU 174	AR	
- 16F	598381	. LABEL-LETTERS L TO R UP. CASE A THRU Z	AR	
- 17	811825	. LABEL-CABLE	AR	
- 18	2122203	. PIN, GUIDE, BRASS, / SUPPLIED W/HARDWARE/	AR	
- 18A	2122637	. PIN, GUIDE CORNER	AR	
- 19	2122258	. PIN-CONTACT, MALE 20/22 AWG	AR	
- 19A	2122260	. PIN, CONTACT- 16-18 AWG	AR	
- 19B	2127867	. PIN, CONTACT- 24-26 AWG	AR	
- 2	5713573	. PLUG, FEMALE- 3 NO. 8 WIRE	AR	
- 21	5213274	. RECEPTACLE, QUICK DISCONNECT-INSUL. SUPP	AR	
- 22	523267	. RECEPTACLE, TAB- 0.798 LG	AR	
- 22A	1127037	. RECEPTACLE, TAB- 0.755 LG	AR	
- 22B	5351177	. RECEPTACLE, TAB- 0.825 LG	AR	
- 23	595720	. RIVET, RULLED FLANGE	AR	
- 24	760259	. SHIELD, GROUNDING SPLICE	AR	

 25,25A AND 25B	 26,26A AND 26B	 27	 28
 29	 30	 31,31A THRU 31D	 32
 33	 34,34A AND 34B	 35	 36,36A THRU 36F
 37 AND 37A	 38	 39	 40 AND 40A
 41	 42 AND 42A	 43 AND 43A	 44
 45			

FIGURE 59. CABLE AND JUMPER ASSEMBLY COMPONENT PARTS. (SHEET 2 OF 3, INDEX NOS. 25-45)

LIST 59. CABLE AND JUMPER ASSEMBLY COMPONENT PARTS

FIGURE- INDEX NUMBER	PART NUMBER	DESCRIPTION	1 2 3 4				UNITS PER ASM.	USABLE ON CODE
59 - 25	2122259	. SOCKET, CONTACT- 20-22 AWG					AR	
- 25A	2122261	. SOCKET, CONTACT-18-16 AWG					AR	
- 25B	2127890	. SOCKET-CONTACT AWG 26-24					AR	
- 26	2122202	. SOCKET, GUIDE-CENTER					AR	
- 26A	2122636	. SOCKET, GUIDE-CORNER 75 AND 104 POS CONN					AR	
- 26B	2122735	. PIN-SOCKET GUIDE					AR	
- 27	2127986	. SPRING, LOCKING- 26 POS CONNECTOR					AR	
- 28	813807	. STRAIN RELIEF, TOP-LEFT HALF CABLE					AR	
- 29	5352967	. STRAIN RELIEF, 20 STRANDS-.05 DIA					AR	
- 30	5275481	. STRAIN RELIEF					AR	
- 31	477980	. TERMINATOR, SHIELD- 0.230 DIA X 0.460 LG					AR	
- 31A	535640	. TERMINATOR, SHIELD- 0.260 DIA X 0.460 LG					AR	
- 31B	2160821	. TERMINATOR, SHIELD- 0.230 DIA X 0.460 LG					AR	
- 31C	5372693	. TERMINATOR, SHIELD- 0.360 DIA X 0.460 LG					AR	
- 31D	188609	. FERRULE, CABLE, SHIELED					AR	
- 32	760260	. TERMASHIELD, INSULATING SLEEVE					AR	
- 33	82725	. TERMINAL, LUG-INS 6AWG 17/64 MTG HOLE					AR	
- 34	92784	. TERMINAL-RING, 18-20 AWG #8 HOLE, INS					AR	
- 34A	2101326	. TERMINAL, RING-12-10 AWG					AR	
- 34B	2101327	. TERMINAL, LUG-INS 10/12AWG 1/4 MTG HOLE					AR	
- 35	113750	. TERMINAL, LUG-NONINS 16AWG NO. 8 MTG HOLE					AR	
- 36	124439	. TERMINAL, RING-10 AWG					AR	
- 36A	186968	. TERMINAL-RING, 10-12 AWG, #8 HOLE, INS					AR	
- 36B	334910	. TERMINAL-RING, 14-16 AWG, #6 HOLE, INS					AR	
- 36C	334921	. TERMINAL-RING, 18-22 AWG, #6 HOLE, INS					AR	
- 36D	334768	. TERMINAL, RING-16-22 AWG 1/4 MTG HOLE					AR	
- 36E	334932	. TERMINAL-RING, 18-22 AWG, #10 HOLE, INS					AR	
- 36F	360370	. TERMINAL-WIRE RING TONGUE					AR	
- 37	186596	. TERMINAL-RING LUG INSULATED					AR	
- 37A	359695	. TERMINAL, RING LUG-INSULATED					AR	
- 38	187243	. TERMINAL, SMALL TAPER					AR	
- 39	253740	. TERMINAL-RING, 10-12 AWG, #6 HOLE, INS					AR	
- 40	335327	. TERMINAL, LUG- SCREW SIZES 8 THRU 10					AR	
- 40A	253970	. TERMINAL					AR	
- 41	335970	. TERMINAL, LUG- 8 AWG 1/4 MTG HOLE					AR	
- 42	501848	. TERMINAL, LUG-INS 6AWG NO. 1/4 MTG HOLE					AR	
- 42A	511544	. TERMINAL, LUG-INS 6AWG NO. 10 MTG HOLE					AR	
- 43	596255	. TERMINAL, SLIP-ON					AR	
- 43A	5214594	. TERMINAL, SLIP ON-18-22 AWG					AR	
- 44	804715	. TERMINAL, LUG-INS 18/22AWG NO. 4 MTG HOLE					AR	
- 45	5270658	. TERMINAL, LUG-RIGHT ANGLE, 8-10 STUD SIZE					AR	

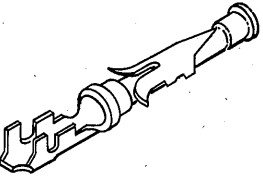
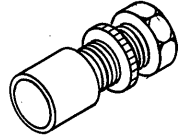
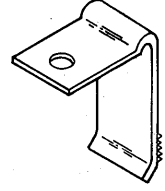
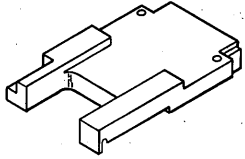
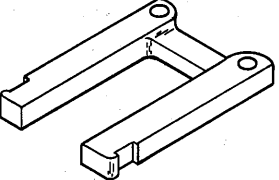
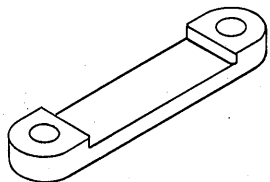
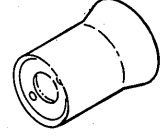
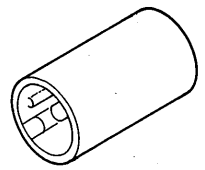
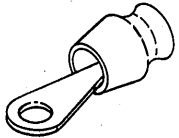
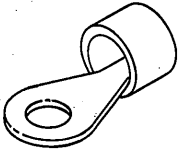
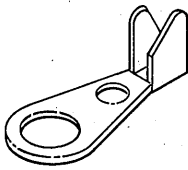
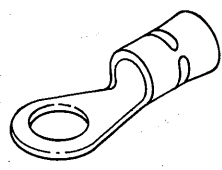
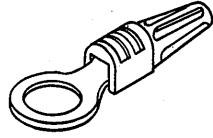
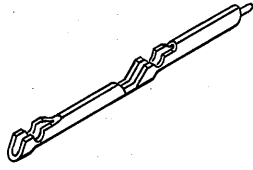
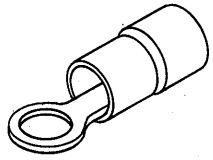
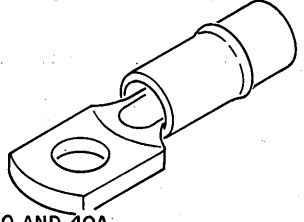
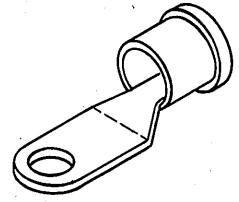
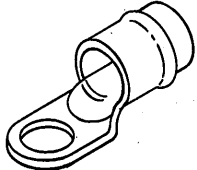
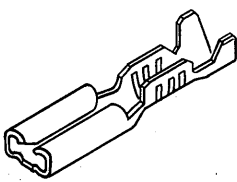
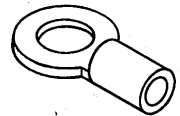
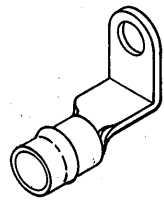
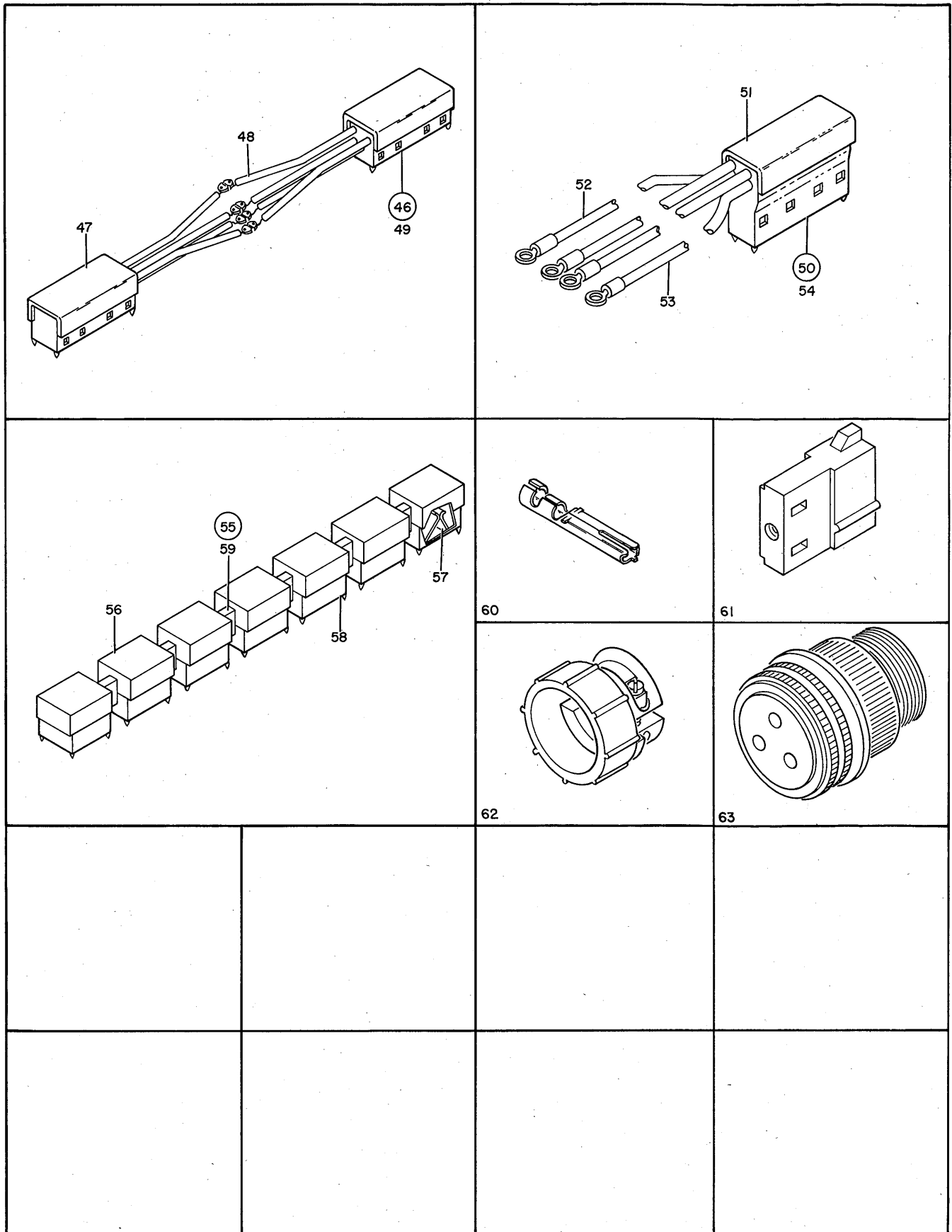

FIGURE 59. CABLE AND JUMPER ASSEMBLY COMPONENT PARTS. (SHEET 3 OF 3. INDEX NOS. 46-63)

NUMERIC INDEX

PART NO.	FIGURE-INDEX NUMBER	PART NO.	FIGURE-INDEX NUMBER	PART NO.	FIGURE-INDEX NUMBER	PART NO.	FIGURE-INDEX NUMBER			
99	12 -104	6935-CONT	17A-108	10295	38 -108B	22478-CONT	55 - 21B			
	22 - 13			22 - 86	11598		12 - 15		12 - 30	
	38 -113			22 - 90			12 - 19		39 - 28A	
119	12 - 39			28 - 6			12 -132		17A- 23	
	45 - 70			28 - 85			13 - 12		17A- 41	
337	45 - 24			37 - 21			22 -109		18 - 25	
367	1 - 64		9092	12 - 34			26 - 8		18 - 33	
	37 - 24				12 -131			27 -1020		18 - 40
	38 -114				18 - 49			27 -120		18 - 44
	45 - 34				22 -107			28 - 81		30 - 11
2031	12 - 75			25 - 49		33 - 66		30 - 18		
2384	14 - 68			25 - 53		37 - 5		30 - 54		
	15 - 52A			25 - 57		37 - 27		30 - 59		
	15 - 75			25 - 94		38 -108E		37 - 40		
	16 - 46A			27 - 30		39A- 14		37 - 42		
	17 - 55			27 -119		45 - 37		37 - 51		
3550	1 -156		28 - 82		46 - 5		39 - 6			
	12 - 68		30 - 75		46 - 91		39 - 14			
	12 - 91		33 - 65		46 -188		46 - 57			
	12 - 92C		37 - 26		47 - 21		46 - 74			
	17A-109		37 - 31		47 - 24		55 - 12B			
	22 - 91		37 - 31C		51 - 2		55 - 14			
	25 - 46		37 - 49	11891	43 - 46	25891	53 - 75			
	31 - 6		37 - 56		45 - 13	25895	25 - 76			
	32 - 6		39 - 38		53 - 84	28413	4 - 6			
	33 - 45		39A- 3	15484	17A- 58		12 - 5			
	33 - 49		39A- 13	15887	39 - 56		18 - 61			
	34 - 34		47 - 20	15889	28 - 78		25 - 63			
	34 - 39		51 - 21	18272	1 -105		27 -101			
	40 - 8	10170	1 - 84	22478	1 -113		27 -105			
	41 - 9			17 - 2		5 - 23		28 - 39		
	42 - 5			17 - 75		6 - 33		28 - 63		
	44 - 64			22 - 44		7 - 12		28 - 69		
	45 - 20			22 - 46		8 - 12		33 - 75		
	46 -200			22 - 48		8 - 21		34 - 51		
	53 - 71			23 - 48		9 - 9		34 - 78		
	53 - 87			24 - 54		9 - 23		39 - 59		
	53 -100			27 - 48		9 - 28	32042	4 - 2		
3960	1 -155			27 - 70		10 - 22			4 - 4	
	17A- 76		28 - 2		10 - 26			4 - 7		
	28 - 44		30 - 34		10 - 35			4 - 9		
	37 - 22		30 - 39		10 - 55			4 - 21		
	46 -202		33 - 20		12 - 63			4 - 23		
	53 - 72		33 - 30		12 -112			4 - 31		
4636	37 - 61		33 - 60		14 - 61C			4 - 33		
	37 - 71		34 - 21		17A- 92			12 - 47		
	37 - 75		34 - 47		18 - 7			12 - 87		
	43 - 85		37 - 80		18 - 20		12 -103			
	44 - 56		38 - 18		18 - 26		12 -106			
	51 - 25		38 - 32		18 - 30		12 -135			
5528	1 - 62		38 -102		18 - 35		12 -137			
	27 - 89		39 - 24D		18 - 38		22 - 3			
	33 - 54		39 - 42		18 - 42		22 - 6			
	39 - 80		39 - 45		18 - 46		22 - 11			
	46 - 44		43 - 3		25 - 42		22 - 29			
5644	1 - 59		43 - 28		28 - 28		22 - 34			
	17A- 99		43 - 71		30 - 70		22 - 36			
5677	4 - 18		43 - 99		37 - 53		22 - 41			
	4 - 26		44 - 29		39 - 28B		22 - 51			
	38 -110		44 - 34		43 - 33		22 - 54			
	38 -116		44 - 40		44 - 51		22 - 58			
	44 - 18		44 - 53		45 - 48		22 - 69			
	47 - 22		45 - 6		45 - 71		22 - 72			
6324	53 - 64		45 - 66		46 - 9		22 - 87D			
6364	5 - 11		45 - 81		46 - 14		22 - 93			
	11 - 39		45 - 98		46 - 37		22 - 95			
	12 - 24		46 - 31		46 - 41		22 - 95D			
	17A-100		46 - 49		46 - 45		22 - 97			
	27 - 68		46 - 93		46 - 76		22 - 97D			
	27 - 71		46 -102		46 - 81		22 -101			
	28 - 49C		46 -106		46 -121		22 -103			
	33 - 72		46 -196		46 -126		22 -105			
	34 - 59		51 - 30		46 -130		22 -114			
	34 - 73		52 - 2		46 -135		22 -116			
	43 - 56		52 - 28		46 -140		22 -118			
	53 - 25		53 - 2		46 -206		22 -120			
	53 - 80		53 - 38A		47 - 5		22 -121B			
6935	1 -157		53 - 40		53 - 94		25 - 48			
	12 - 67		53 - 54		55 - 12C		25 - 56			
	12 - 9C		53 -108		55 - 15		26 - 19			

PART NO.	FIGURE-INDEX NUMBER	PART NO.	FIGURE-INDEX NUMBER	PART NO.	FIGURE-INDEX NUMBER	PART NO.	FIGURE-INDEX NUMBER
32042-CONT	27 - 6	34512-CONT	37 - 17	38686	22 -123	55901	1 - 11
	27 -102A		37 - 44	38688	17A-107		5 - 8
	27 -115		37 - 63		22 -124		6 - 3
	28 - 55		38 - 29	45259	53 - 9		7 - 3
	30 - 3		39 - 63	45690	12 - 18		8 - 5
	30 - 37		39 - 83		12 - 33		9 - 37
	35 - 4		44 - 72		12 - 57		10 - 3
	37 - 11		46 - 7		12 - 95		11 - 43
	37 - 14		46 - 12		12 -130		12 - 2
	37 - 55		46 - 35		18 - 50		12 - 56
	37 - 65		46 - 39		22 -108		18 - 2
	37 - 67		46 - 79		23 - 21		18 - 9
	37 - 77		46 -122		24 - 37		18 - 12
	38 -108C		46 -124		25 - 50		18 - 14
	39 - 3		46 -128		25 - 54		18 - 17
	39 - 64		46 -133		25 - 58		18 - 52
	39 - 78		46 -138		25 - 65		22 -112
	43 - 76		46 -205		25 - 93A		23 - 20
	44 - 14		47 - 3		27 - 29		24 - 36
	45 - 88		51 - 6		27 -112		30 - 8
	46 - 3		53 - 67B		30 - 52		30 - 12
	46 - 18	35739	34 - 25		30 - 76		30 - 19
	46 - 22		35 - 21		33 - 64		33 - 69
	46 - 61		43 - 10		34 - 52		34 - 56
	46 - 89		44 - 44		37 - 3		37 - 18
	46 - 90		53 - 16		37 - 25		38 - 27
	46 -110		53 - 50		37 - 30		38 - 30
	46 -114		53 - 89		37 - 31D		39 - 7
	46 -117		53 -101		37 - 48		39 - 16
	46 -152	36109	22 -126		37 - 57		39A- 9
	46 -162		28 - 7		38 - 28		43 - 41
	51 - 8	36844	12 - 89		38 -108D		43 - 86
	51 - 11		22 - 84		39 - 39		44 - 50
	51 - 13		22 - 89		39A- 4		44 - 57
	51 - 16	37913	17 - 10		39A- 12		45 - 72
	51 - 19		23 - 6		43 - 48		46 - 8
	51 - 27		24 - 7		45 - 35		46 - 13
32617	1 - 30		30 - 30		46 - 20		46 - 36
	1 - 67		38 - 86		46 - 24		46 - 40
	17A- 88		53 - 30		46 - 63		46 - 46
	18 - 48		53 - 36		46 -112		46 - 75
	25 - 52		53 -116		46 -116		46 - 80
	25 -101	38051	44 - 61		46 -154		46 -120
	30 - 50	38235	12 - 23		46 -164		46 -125
	30 - 74		17 - 24		46 -186		46 -129
	33 - 35		27 - 64		47 - 19		46 -134
	33 - 63		27 - 99		51 - 20		46 -139
	34 - 16		28 - 61	48594	1 - 78		46 -207
	37 - 47		34 - 30		17A- 67		55 - 12D
	39 - 37		35 - 15		28 - 23		55 - 16
	44 - 12		38 - 67		12 - 14	55918	17A- 43
33370	17A- 6		44 - 59	52580	25 - 85		28 - 56
34512	1 - 28B		57 - 19	53193	33 - 55		28 - 86
	1 - 36	38262	1 -138B	54291	12 - 66		28 - 93
	1 - 42	38348	28 - 59	55586	17A- 81		39A- 2
	1 - 47	38350	22 - 66		1 - 82		52 - 25
	1 - 73	38352	17A- 96	55726	14 - 30	56079	12 - 6
	1 -104	38353	38 - 23		14 - 41		12 -122
	1 -112	38354	17A- 61		15 - 31		13 - 13
	1 -159	38368	53 - 93		15 - 43		13 - 20
	12 - 55		53 - 97		16 - 39		22 - 4
	12 - 60	38391	14 - 14		17 - 75		22 - 7
	12 - 62		15 - 14		25 - 10A		22 - 38
	12 -111		16 - 22		25 - 18		22 - 42
	12 -114		17 - 32		25 - 29		22 - 56
	16 - 6	38442	33 - 61		27 - 73		22 - 59
	16 - 8		34 - 48		27 - 95		22 - 73
	17 - 3		43 - 82		34 - 28		22 -121
	17A-116		44 - 30		43 - 12		25 - 38
	18 - 1	38443	17A- 97		43 - 15		25 - 64
	18 - 6		34 - 58		43 - 69		25 - 72
	18 - 13		45 - 43		44 - 9		25 - 94A
	18 - 19		55 - 28		44 - 74		26 - 7
	18 - 51		57 - 2		45 - 27		27 - 93
	18 - 55B	38447	53 - 23		45 - 30		27 -102B
	22 - 95B	38450	34 - 64		45 - 58		28 - 11
	22 -111	38451	44 - 22		45 - 62		30 - 4
	23 - 19	38452	43 - 55		53 - 33		30 - 51
	24 - 35		44 - 38		53 - 79		33 - 67
	30 - 68	38454	43 - 40		53 -118		34 - 54

PART NO.	FIGURE-INDEX NUMBER	PART NO.	FIGURE-INDEX NUMBER	PART NO.	FIGURE-INDEX NUMBER	PART NO.	FIGURE-INDEX NUMBER
56079-CCNT	35 - 8	56792-CONT	46 - 69	108478	17 - 4	186759-CCNT	53 -106
	35 - 11	58207	1 - 49	109872	56 - 16	186944	46 -165
	37 - 1D		1 - 86	110029	53 - 12	186962	39 - 74
	37 - 4		1 - 88	110286	12 - 64	186968	55 - 5
	37 - 12		1 -107		17A- 80		59 - 36A
	37 - 15		1 -109	111256	46 - 28	187243	38 - 61
	37 - 78		6 - 5A	111264	46 - 25		59 - 38
	38 -111		18 - 29	112628	23 - 25	187467	46 -165A
	38 -117		18 - 37		24 - 41	187479	52 - 3
	39 - 4		25 - 2	113750	59 - 35	187858	27 - 51
	39 - 40		25 - 77A	120571	37 - 35	188555	12 - 49
	39 - 49		25 - 80	123073	38 -103	188609	59 - 31D
	39 - 65		33 - 68	123075	53 - 59	189138	38 - 40
	45 - 13A		34 - 55	123077	30 - 77	191480	46 -155
	45 - 36		37 - 8	123786	46 - 27	191481	53 - 39
	46 - 4		39 - 57	124226	55 - 24A	192589	54 - 1
	46 - 19		39 - 61	124436	30 - 14	203801	34 - 75
	46 - 23		44 - 21		38 -107	204464	27 - 17
	46 - 62		46 - 72		39 - 10	205331	38 - 60
	46 -111		52 - 18	124439	59 - 36	207324	31 - 1
	46 -115		56 - 14	124582	17A- 68		32 - 8
	46 -153	58865	17A- 7	125930	1 - 65		40 - 1
	46 -163	60646	39 - 28C		25 - 95	207340	42 - 10
	46 -187		43 - 36	126036	46 -160	208226	42 - 8
	47 - 23		45 - 47	128455	38 - 38	208227	53 - 37
	51 - 3	62031	17A-113	130434	13 - 19	208235	53 - 31
	51 - 9		43 - 23		35 - 7	208237	27 -102
	51 - 14		44 - 31		35 - 1C	208528	46 -136
	51 - 28		44 - 60	130987	28 - 79	209002	38 - 73
	52 - 26	65756	31 - 5	132773	53 - 82	210883	27 - 61
	53 - 63		32 - 5	132812	54 - 10		43 - 9
56121	12 - 37		40 - 7	138754	46 -203		44 - 43
	25 -102		41 - 8	138756	46 - 71		45 - 83
	34 - 53		42 - 6		47 - 1		46 -159
	43 - 47		44 - 67	144424	18 - 58		46 -197
	12 - 21	71776	37 - 20		38 - 26		52 - 7
	12 - 51	72828	1 - 38	147297	17A- 63		53 - 47
	13 - 2	75449	12 - 11	149898	23 - 45B	210884	27 - 60
	13 - 8	76574	17A- 75		23 - 45F		46 -158
	13 - 17		22 -125		24 - 45B		52 - 8
	28 - 35		28 - 45		24 - 45F		53 - 48
	30 - 40		28 - 66	150209	27 - 20	210984	27 - 22
	32 - 31		45 - 18	151598	52 - 11		27 - 52
	33 - 41		46 -201		53 - 60		27 - 58
	33 - 74	78999	25 - 83	160017	28 - 84		28 - 13
	34 - 29	79778	12 - 50		31 - 4		46 -156
	34 - 31	79779	27 - 3A		32 - 4		46 -166
	34 - 60	80352	43 - 7		33 - 44		52 - 4
	35 - 16	80651	28 - 41		33 - 48		54 - 2
	38 - 33		28 - 72		34 - 35	210985	27 - 55
	38 - 68	81693	5 - 10		34 - 38		46 -170
	39 - 46		11 - 38		40 - 6		54 - 4
	43 - 13		12 - 20		41 - 7	210986	27 - 54
	43 - 72		13 - 7		42 - 4		46 -169
	44 - 35		13 - 16		44 - 63		54 - 5
	44 - 54		33 - 23		45 - 17	213507	38 -101
	45 - 28		33 - 40		53 - 99	213693	39 - 75
	45 - 31		38 -105	161351	17A-104		42 - 2
	45 - 59		39 - 73		28 - 47		45 - 54
	45 - 63		43 - 22	179946	53 - 65	215680	38 - 41
	45 - 67		45 - 11	186036	1 -166	216073	27 - 82
	45 - 79		46 - 97		53 - 86		45 -103
	45 - 84		52 - 36	186596	59 - 37	216076	27 - 79
	45 - 99		55 - 2	186712	8 - 8		33 - 10
	46 - 32		57 - 7	186758	1 - 36		34 - 6
	46 - 53	82353	34 - 24		25 - 40		43 - 67
	46 - 68	82725	59 - 33		43 - 39		44 - 10
	46 - 87	83606	4 - 12		44 - 49		45 -1CC
	46 - 94		4 - 14		46 -119		53 - 27
	46 - 99	90261	28 - 67		53 - 96	216082	27 - 78
	46 -103	91373	9 - 5	186759	11 - 36	216083	27 - 75
	46 -107		10 - 7		11 - 46	216085	27 - 74
	46 -192		10 - 9		11 - 54	216087	27 - 76
	53 - 18	91469	27 - 53		25 - 91		27 - 80
	53 - 51	91610	28 - 74		27 -104		45 -102
	57 - 3		28 - 91		43 - 30	216088	27 - 77
	57 - 14	92784	53 - 43		43 - 56		27 - 81
	57 - 24		59 - 34		44 - 37		45 -101
	57 - 28	98865	53 -117		53 - 67	216197	45 - 12
56792	46 - 54	106419	22 -1C6		53 -104	216206	45 - 95

PART NO.	FIGURE-INDEX NUMBER	PART NO.	FIGURE-INDEX NUMBER	PART NO.	FIGURE-INDEX NUMBER	PART NO.	FIGURE-INDEX NUMBER
216207	43 - 65	257187-CONT	28 - 49D	257985-CONT	17A- 47	317157-CONT	53 - 78
	44 - 7		33 - 42		23 - 5	317158	53 - 91
216362	25 - 39		33 - 73		24 - 6	317200	45 - 57
216452	38 - 94		34 - 32		30 - 28	317218	54 - 11
216475	53 - 77		34 - 61		38 - 84	317232	52 - 6
216492	38 - 95		34 - 74		39 - 23	317262	53 - 81
217017	33 - 52		43 - 24		47 - 12	317276	45 - 55
	34 - 40		43 - 97		47 - 16	317286	28 - 58
	44 - 66		46 - 86		48 - 7	317296	54 - 18
	45 - 21		46 -100		49 - 8		59 - 16
217019	43 - 49		53 - 19	257986	5 - 12	317297	59 - 16A
217051	43 - 90		53 - 26		11 - 40	317298	59 - 16B
217077	43 - 6		57 - 4		12 - 25	317299	59 - 16C
	45 - 9		57 - 15		16 - 10	317300	59 - 16D
217082	38 - 96		57 - 25		17 - 13	317328	17 - 25
220690	43 - 25		57 - 29		17A-114	317429	5 - 14
220764	46 -213	257189	1 - 10		23 - 9	319300	12 - 46
220918	27 - 42		5 - 7		24 - 10		17A- 42
221790	34 - 63		5 - 21		28 - 49B	320456	46 - 48
	39A- 6		6 - 2		33 - 25		53 - 32
	39A- 8		6 - 31		34 - 72	320570	57 - 9
	43 - 73		7 - 2		38 - 69	320606	38 - 22
	53 - 56		7 - 10		43 - 95	321271	45 - 51
222027	25 - 67		8 - 4		45 - 32	321483	43 - 79
222098	38 - 92		8 - 10		45 - 60	321603	28 - 32
223227	1 - 54		8 - 19		45 - 68	322028	12 - 92B
223410	26 - 6		9 - 7		45 - 85		17A- 74
223528	25 - 98		9 - 21		46 - 33	322029	22 - 85
226027	18 - 59		9 - 26		46 - 95		25 - 45
234565	17A- 91		9 - 36		46 - 98	322061	22 - 37
236550	17A- 84		10 - 2		46 -104		22 - 55
	38 - 55		1C - 20		46 -108	322065	1 - 59
	38 - 63		10 - 24		46 -193		13 - 1
	38 - 83		10 - 33		53 - 17		17A-112
	47 - 10		10 - 53		53 - 24	322266	46 -171
	47 - 14		11 - 42		53 - 90	322270	54 - 6
	53 -114		14 - 61B		53 -102	322550	17 - 44
236569	24 - 48		17A- 50	263550	38 - 13B		17A- 2
236849	18 - 57		17A- 94	264641	1 - 32		17A- 38
	25 - 19A		18 - 8		1 - 69		28 - 62
	25 - 37		18 - 11	264998	6 - 8		45 - 78
	25 - 59		18 - 16	284424	38 - 64		46 -173
	25 - 71		26 - 14	300721	38 - 8		46 -176
	27 - 84		28 - 30	301679	33 - 17		46 -179
	27 - 86		30 - 9	301821	53 - 8		46 -182
	27 - 92		30 - 13	302090	18 - 53		46 -191
	27 -107		30 - 20	302131	18 - 55		52 - 14
	30 - 36		39 - 8	304478	16 - 69		55 - 21A
	33 - 33		39 - 15	308789	1 - 138A		57 - 13
	34 - 11		43 - 37	311462	1 - 44		57 - 27
	34 - 50		43 - 42	312573	30 - 16	322551	38 - 2
	39 - 43		43 - 87		38 -108		38 - 71
	39 - 81		44 - 52		39 - 12		46 - 52
	44 - 16		44 - 58	312575	30 - 15		46 - 67
	45 - 89		45 - 46		38 -106	322552	35 - 18
	53 - 6		45 - 73		39 - 11	322555	43 - 93
	53 - 62		46 - 47	313289	39 - 69	322563	46 - 16
237455	46 -189		46 -208	313997	27 - 15	322599	53 - 67D
244111	17A- 86		53 - 14	314047	33 - 15	322609	53 - 67E
251970	25 - 9		53 - 67C		34 - 68	322765	31 - 7
	27 - 8		55 - 12E	316187	35 - 19		32 - 7
	27 - 19		55 - 17	316247	52 - 20		40 - 9
	28 - 34	257701	1 - 52	316807	33 - 71		41 - 5
	39 - 72	257957	9 - 19	316996	43 - 43		42 - 7
	46 -210	257959	6 - 7		52 - 30	322766	46 -157
	48 - 2		6 - 11	317001	38 - 4	323681	52 - 15
	48 - 5	257965	7 - 4	317003	38 - 5	323836	35 - 20
	49 - 6	257969	23 - 49	317009	38 - 72	323838	57 - 6
	49 - 11		24 - 55	317010	38 - 3	323839	33 - 22
	52 - 22	257984	1 - 79	317015	46 -146		44 - 42
252632	22 -122		1 -1380	317019	43 - 17		53 - 46
253740	13 - 21		30 - 29	317022	27 - 96	323840	46 -168
	59 - 39		39 - 24	317077	44 - 25	323841	52 - 13
253970	59 - 40A		47 - 11	317105	54 - 9	323842	46 -190
255629	28 - 89		47 - 15	317131	46 -167	324948	55 - 9
256463	12 - 65		48 - 6	317132	54 - 3	324999	38 - 62
257187	1 - 60		49 - 7	317138	27 - 49	325660	25 - 74
	13 - 3		53 - 29		46 - 82	326367	43 - 26
	13 - 9		53 - 35	317145	46 - 56	327921	16 - 75
	27 - 67	257985	17 - 9	317157	52 - 21		17 - 23

PART NO.	FIGURE-INDEX NUMBER	PART NO.	FIGURE-INDEX NUMBER	PART NO.	FIGURE-INDEX NUMBER	PART NO.	FIGURE-INDEX NUMBER
327921-CCNT	17 - 56	338238-CCNT	46 -149	438538-CONT	17A- 56	476744	38 - 75
	18 - 4	338327	39 - 51	438539	32 - 11	477974	28 - 37
	22 - 87C	341492	43 - 8	438547	17A- 20	477980	59 - 31
	22 - 97A	342250	46 -212	438548	25 - 4	478043	43 - 44
327922	30 - 6	347805	17 - 21		27 -123		44 - 69
	22 - 1	347807	17 - 22		28 - 21	478045	43 - 21
	22 - 87A	347820	38 - 58		38 - 15	479064	32 - 9
327923	18 - 5	349736	12 - 58		54 - 12	479309	8 - 16
	18 - 18		23 - 29	438550	54 - 15	479714	43 - 61
	18 - 31		24 - 45		17 - 8		44 - 3
	22 - 87B		27 - 32		17A- 46	479999	7 - 8
	22 -121A	350564	41 - 11		18 - 54	481439	33 - 13
331065	57 - 10	350663	30 - 5		23 - 4		34 - 67
331982	28 - 27	350836	59 - 9		24 - 5	481443	44 - 23
332620	1 - 28	350837	59 - 8		38 - 90	481467	32 - 1
	1 -121	351228	34 - 27	438551	17A- 24	481484	40 - 2
	1 -153	352825	33 - 19		17A- 26	481514	41 - 3
	1 -162		44 - 39		53 - 28	481921	40 - 3
	12 - 32	353526	25 - 96		53 - 34	482188	7 - 6
	12 -109	353632	45 - 64	438552	17A- 29	482195	9 - 16
	12 -126	356740	38 - 13	438553	17A- 9		10 - 14
	12 -139	356742	14 - 64	438566	52 - 34	482217	9 - 17
	22 - 97B		15 - 49	438567	57 - 22		10 - 15
	27 - 28		16 - 43	438570	34 - 71	482219	7 - 7
	28 - 10		17 - 57		57 - 23	482221	9 - 15
	28 - 49		39A- 5	438581	12 - 74		10 - 13
	28 - 52	357433	12 - 22	438582	12 - 80		11 - 11
	33 - 38		27 - 69		14 - 77	482030	43 - 20
	34 - 13	359695	47 - 7		16 - 78	483106	46 -145
	37 - 2		59 - 37A		17 - 59	483111	27 - 11
	37 - 29	360370	53 - 42	438586	30 - 7	483115	38 - 76
	37 - 31B		59 - 36F	438587	17A- 16	483982	10 - 46
	46 -185	360433	59 - 7		39 - 67	486036	28 - 65
	47 - 18	360882	25 - 84	438588	17A- 33	491221	43 - 16
332747	17A-105		46 - 29		37 - 55	491228	31 - 2
333082	52 - 36A	361503	46 -144		37 - 69		32 - 2
334012	12 -133	362206	44 - 15		37 - 73		39 - 76
334219	59 - 16E		53 - 30A		46 -143		40 - 4
334768	47 - 6	363447	25 - 72A	438589	17A- 32		41 - 4
	53 - 44	364707	52 - 12	438590	51 - 23		42 - 1
	59 - 36D	365048	38 - 45	438592	45 - 45	491320	39 - 70
334910	52 - 5	367115	38 - 21	438593	43 - 32	492425	5 - 15
	59 - 36B	368353	28 - 18	438602	12 -129	492448	33 - 14
334921	28 - 36	369207	30 - 1		45 - 92		34 - 66
	35 - 19A		39 - 1	438605	27 -111		43 - 91
	43 - 5		46 - 1	438623	46 -199		44 - 24
	45 - 8	369613	8 - 15		53 - 83		45 - 53
	55 - 4	369652	38 - 10	442958	43 - 34	492570	43 - 18
	59 - 36C		38 - 74		53 - 10	501551	43 - 88
334932	27 - 96A		38 - 97	442959	43 - 94	501848	59 - 42
	59 - 36E	369654	38 - 5	443052	34 - 70	502475	42 - 9
334949	43 - 89		38 - 98	445304	53 - 38	503498	47 - 8
335017	33 - 12	369849	52 - 19	450821	30 - 55	504189	30 - 41
	34 - 65		52 - 29		56 - 18		39 - 47
	43 - 80	372966	33 - 1	450957	28 - 57		39 - 47
	44 - 27		44 - 4	460471	46 -194	504318	12 - 76
335138	45 - 50	372969	43 - 63	472168	23 - 24	507142	53 - 7
335327	53 - 45	372975	34 - 1		24 - 40	507144	43 - 35
	55 - 7	374223	27 - 34	472250	41 - 2		53 - 11
	59 - 40	374772	33 - 2	472707	28 - 73	507234	27 - 10
335328	43 - 83		34 - 2	473530	43 - 68	507536	43 - 59
335970	59 - 41		43 - 64		44 - 8	507575	38 - 20
337193	46 -195		44 - 5		53 - 22	507796	12 -157
337545	42 - 12		45 - 1	473531	27 - 4		27 -118
337549	33 - 58	374785	27 - 36		28 - 42		39A- 11
	34 - 45	374788	27 - 37		28 - 71	509638	33 - 11
	44 - 73	374826	45 - 2	473536	25 - 87	509772	1 -123
	45 - 25	374862	53 - 4		25 - 89	510316	45 - 61
338169	23 - 26	374863	53 - 3	473544	27 - 5	510379	1 - 59
	24 - 42	374981	45 - 3	473547	33 - 5	510388	46 - 83
	38 - 85	374982	27 - 35		34 - 7	510468	28 - 31
	46 -211	375316	27 - 38		43 - 66	511063	46 - 26
	48 - 8	381741	1 -138		44 - 11	511544	59 - 42A
	49 - 9		1 -143		45 - 96	511553	38 - 25
	53 -115		1 -148		53 - 27A	512663	57 - 11
338238	17A-118	383608	17A- 69	473582	43 - 50	513668	1 - 81
	27 - 14	419130	45 - 49	473592	33 - 50	513669	37 - 79
	28 - 19	437261	43 - 92		34 - 41		51 - 20
	30 - 27		45 - 44		44 - 68	515380	26 - 9
	39 - 22	438538	16 - 49	473629	8 - 17		26 - 15

PART NO.	FIGURE-INDEX NUMBER	PART NO.	FIGURE-INDEX NUMBER	PART NO.	FIGURE-INDEX NUMBER	PART NO.	FIGURE-INDEX NUMBER
515381	26 - 10	73C432-CCNT	25 - 78	811476-CCNT	23 - 12	811863	16 - 36
	26 - 16		27 - 16		24 - 13A	811868	17 - 71
515620	57 - 8		28 - 53	811481	14 - 12		23 - 34
515718	26 - 12		28 - 75		15 - 12		24 - 26
517126	46 -177		43 - 1		16 - 20	811869	17 - 67
517892	46 -175		44 - 32		17 - 19		23 - 30
517913	13 - 22		44 - 47		17 - 30		24 - 22
517928	24 - 47		45 - 74		17A- 13	811872	14 - 37
518C72	6 - 29		57 - 5		17A- 30		15 - 27
518578	33 - 5	721626	17 - 6		23 - 13	811873	14 - 33
	34 - 19		23 - 3A		23 - 42		15 - 23
519043	46 - 15		24 - 4		24 - 13B	811876	16 - 35
523176	8 - 13	731629	39 - 48		24 - 18	811877	16 - 31
	59 - 6	731630	1 -117	811483	14 - 2	811881	14 - 32
523267	59 - 22		1 -136		15 - 2		14 - 42
523269	48 - 1		1 -141		16 - 1		15 - 32
	49 - 10		1 -146		17 - 33		15 - 45
524966	46 -180	724483	16 - 9		23 - 2		16 - 40
526378	13 - 10		24 - 51		24 - 1		17 - 76
528138	39 - 41	735376	38 - 19		59 - 50		23 - 38
528403	53 - 76	738378	1 -151	811485	59 - 53		24 - 30
528484	25 - 36	740501	13 - 5	811495	59 - 52	813179	14 - 20A
529203	45 - 15	749C33	10 - 47	811496	59 - 48		15 - 21
	45 - 56	749089	4 - 16	811497	23 - 45		16 - 29
529214	32 - 10	76C221	12 - 71		24 - 21		17 - 65
529691	44 - 65	76C259	59 - 24	811515	14 - 19		24 - 12
532393	37 - 66	76C260	59 - 32		15 - 19	813261	59 - 59
	38 - 31	8C41C9	13 - 6		16 - 27	813268	17 - 34
	39 - 58	804715	59 - 44		17 - 29	813271	17 - 34
532991	12 - 17	806569	33 - 26	811517	14 - 20		59 - 55
533360	34 - 20		44 - 45		15 - 20	813321	12 -147
533534	43 - 27	808369	6 - 14		16 - 28		14 - 51
	43 - 81	811417	14 - 21	811520	14 - 11		14 - 58
	43 - 98		14 - 29		15 - 11		15 - 56
	44 - 28		14 - 40		16 - 19		15 - 68
534768	18 - 43		15 - 22		17 - 35		16 - 5C
535640	59 - 31A		15 - 30		23 - 11		16 - 60
551687	10 - 29		15 - 42		24 - 11		16 - 7C
	10 - 49		16 - 30	811530	17 - 7		17 - 49
	11 - 50		16 - 38	811534	12 - 73		22 - 99C
552994	46 -142		17 - 66	811536	17 - 15	813549	59 - 56
553380	38 - 39		17 - 74		23 - 14	813681	59 - 57
556450	12 - 71A		23 - 29C		24 - 14	813703	59 - 58
586711	12 -145		23 - 37	811554	23 - 3	813706	12 - 82
	14 - 57		24 - 13		24 - 3		12 -119
	15 - 55		24 - 29	811556	17 - 1		12 -121
587834	1 -168	811421	30 - 63	811568	24 - 15		12 -124
587866	1 -167	811422	15 - 18	811570	23 - 15		12 -155
587874	1 -165		16 - 26	811576	14 - 17		14 - 63
587875	1 -164		17 - 28		15 - 17		14 - 75
589714	52 - 9		23 - 44		16 - 25		15 - 49A
589715	52 - 10		24 - 20	811577	24 - 17		15 - 49D
589759	27 - 56	811426	14 - 7	811581	17 - 16		15 - 51
594234	4 - 27		14 - 10	811621	14 - 1		15 - 62
595256	31 - 3		15 - 7		15 - 1		15 - 73
	32 - 3		15 - 10		16 - 2		16 - 45
	40 - 5		16 - 15		23 - 1		16 - 65
	41 - 6		16 - 18		24 - 2		16 - 74A
595704	18 - 3		17 - 12		59 - 46		16 - 76
595720	59 - 23		17 - 27	811742	14 - 6		16 - 76B
596255	43 - 58		17 - 40		15 - 6		16 - 80
	59 - 43		17 - 74		16 - 14		17 - 53
597671	1 - 58		23 - 8		17 - 11		17 - 57B
597977	38 - 93		24 - 9		17 - 39		17 - 61
598353	46 - 50	811427	12 -128		23 - 7		17 - 63
	46 - 65	811442	14 - 18		24 - 8		23 - 45D
	52 - 32		14 - 43	811802	59 - 11		23 - 45H
598355	46 - 64		15 - 33	811825	17A- 3		23 - 45M
	52 - 31		16 - 41		59 - 17		23 - 45P
598381	59 - 16F		17 - 77	811854	17 - 73		24 - 45D
599557	13 - 31		23 - 40		23 - 36		24 - 45H
599917	46 - 33A		24 - 32		24 - 28		24 - 45K
	46 -131	811474	17 - 20	811855	17 - 72		35 - 2
	4 - 10		23 - 43		23 - 35	813801	59 - 49
628962	46 - 58		24 - 19		24 - 27		59 - 54
631769	37 - 1	811476	14 - 13	811858	14 - 38	813802	59 - 47
725379	10 - 11		15 - 13		15 - 28		59 - 51
727454	5 - 17		16 - 21	811859	14 - 39	813807	59 - 28
	10 - 10		17 - 14		15 - 29	815039	14 - 4
73C432	22 - 39		17 - 31	811862	16 - 37		15 - 4

PART NO.	FIGURE-INDEX NUMBER	PART NO.	FIGURE-INDEX NUMBER	PART NO.	FIGURE-INDEX NUMBER	PART NO.	FIGURE-INDEX NUMBER
815039-CONT	16 - 12	815225-CONT	22 - 99	1090873-CCNT	47 - 4	2123029	22 - 79
	17 - 37	815226	12 - 142		53 - 13		48 - 13
815080	16 - 2A		14 - 48		54 - 16	2123789	38 - 59
	17A- 18		15 - 64	1092125	1 - 56	2125974	12 - 9
815166	14 - 65		16 - 57	1092177	11 - 26	2127867	59 - 12
	15 - 50		17 - 45	1127037	59 - 22A	2127867	59 - 15B
	16 - 44	815263	14 - 36	1127180	12 - 138	2127890	59 - 25B
	17 - 52		15 - 26		22 - 104	2127895	59 - 12A
815167	23 - 45G		16 - 34	1143248	45 - 94	2127986	59 - 27
	24 - 45G		17 - 68	1144956	17A- 54	2127987	49 - 4
815170	22 - 102		23 - 33	1166115	59 - 60	2127989	49 - 16
815171	22 - 100		24 - 25	2101326	55 - 6	2128689	27 - 66
	23 - 45N	815288	12 - 151		59 - 34A		46 - 85
	24 - 45J		17 - 62	2101327	59 - 34B	2129550	14 - 8
815173	12 - 145		23 - 45C	2101389	38 - 24		15 - 8
	23 - 45K		24 - 45C	2102155	44 - 26		16 - 16
815174	12 - 145	815289	15 - 63	2102182	39 - 71		17 - 41
	22 - 99B	815290	12 - 152	2102364	35 - 14	2156671	22 - 31A
815175	12 - 145	815946	14 - 9		38 - 13A	2160821	59 - 31B
	14 - 50		15 - 9		38 - 108A	2180978	30 - 42
	15 - 67		16 - 17		53 - 15	2181284	37 - 6
	16 - 59		17 - 26	2102365	12 - 125	2191737	14 - 66
	17 - 47	815963	14 - 23	2102367	17A- 31		14 - 71
815210	12 - 146		14 - 34	2102368	12 - 71B		16 - 55
	17 - 46		15 - 24		14 - 61A	2414815	38 - 6
	22 - 99A		15 - 35		14 - 69A	2414970	11 - 29
815214	12 - 81		16 - 32		15 - 49B		27 - 44
	12 - 153		17 - 70		16 - 46P	2418257	1 - 35
	14 - 62		23 - 29H		17 - 55A	2495641	10 - 37
	14 - 74		23 - 31	2102369	12 - 71C	2561419	1 - 39
	15 - 72		24 - 23		15 - 49C	2564585	1 - 89
	16 - 64	815964	14 - 24		16 - 76A	2566646	1 - 93
	16 - 79		14 - 35		17 - 57A		1 - 98
	17 - 60		15 - 25	2102582	43 - 31	2566647	1 - 101
815217	12 - 79		15 - 36	2111232	5 - 13	2569395	12 - 92
	12 - 150		16 - 33		38 - 7		22 - 98
	14 - 54		17 - 69		38 - 46		37 - 45
	14 - 61		23 - 29J		38 - 65	2572724	28 - 54
	14 - 67		23 - 32		38 - 77	2572725	28 - 94
	14 - 76		24 - 24		38 - 91	2572726	28 - 88
	15 - 52	816649	12 - 146		43 - 19	2572727	28 - 87
	15 - 59		14 - 53		46 - 84	2572728	28 - 40
	15 - 71		14 - 60		54 - 7	2572729	28 - 48
	15 - 74		15 - 58	2114044	17 - 42	2572733	28 - 92
	16 - 46		15 - 70		17A- 36	2572735	25 - 88
	16 - 53		16 - 52	2114681	17 - 43		28 - REF
	16 - 63		16 - 62		17A- 37	2572736	25 - 77
	16 - 73		16 - 72	2122202	22 - 75	2572763	33 - 59
	16 - 77	824466	10 - 42		49 - 1		34 - 46
	17 - 51	824467	10 - 43		59 - 26	2572765	33 - 76
	17 - 54	824471	10 - 36	2122203	22 - 76	2572766	33 - 56
	17 - 58	825303	38 - 37		49 - 2	2572773	33 - 3
	22 - 99F	827840	11 - 30		59 - 18		34 - 8
815219	12 - 149	845762	46 - 77	2122256	49 - 15	2572789	28 - 49A
	14 - 52	1074145	55 - 7	2122257	59 - 2	2572793	33 - 4
	14 - 59	1090240	55 - 10	2122258	59 - 19		33 - 8
	15 - 57	1090623	10 - 12	2122259	59 - 25		33 - 16
	15 - 69		11 - 10	2122260	59 - 19A		33 - 18
	16 - 51	1090873	5 - 22	2122261	59 - 25A		34 - 5
	16 - 61		6 - 32	2122625	48 - 11		34 - 9
	16 - 71		7 - 11		59 - 3		34 - 69
	17 - 48		8 - 11	2122626	22 - 77	2572828	34 - 43
	22 - 99E		8 - 20		59 - 3A	2572829	34 - 79
815220	12 - 148		9 - 8	2122627	59 - 13	2572833	34 - 10
	14 - 49		9 - 22	2122628	59 - 14	2572845	33 - 7
	14 - 56		9 - 27	2122629	59 - 15		34 - 4
	15 - 54		10 - 21	2122636	22 - 78	2572849	42 - 13
	15 - 66		10 - 25		48 - 10	2572853	42 - 11
	16 - 48		10 - 34		59 - 26A	2572865	33 - 57
	16 - 58		10 - 54	2122637	22 - 80		34 - 44
	16 - 68		17A- 93		48 - 9	2573011	23 - 47
	17 - 50		18 - 27		59 - 18A		24 - 53
	22 - 99D		18 - 34	2122734	49 - 14	2573012	14 - 46
	23 - 45A		18 - 41	2122735	49 - 13		15 - 48
	23 - 45E		18 - 45		59 - 26B		16 - 42
	23 - 45J		25 - 41	2122837	22 - 74		17 - 64
	24 - 45A		26 - 13		49 - 3		23 - 46
	24 - 45E		28 - 29	2122838	59 - 1		24 - 52
815224	12 - 141		30 - 69	2122838	22 - 81	2573847	46 - 55
815225	12 - 143		37 - 52		48 - 12	2574804	1 - 97

PART NO.	FIGURE-INDEX NUMBER	PART NO.	FIGURE-INDEX NUMBER	PART NO.	FIGURE-INDEX NUMBER	PART NO.	FIGURE-INDEX NUMBER
2574805	1 -100	5253823	45 - 80	5261442	25 - 69	5270651	46 - 92
2575295	1 - 99	5253824	45 - 77	5261443	27 - 91	5270658	59 - 45
2611708	25 - 27	5253825	45 - 86	5261445	28 - 43	5271245	46 -198
2611709	25 - 19	5253827	45 - 26	5261446	27 -108	5271288	46 -209
2611713	29 - 22	5253835	45 - 29	5261448	27 -106		48 - 4
2611714	25 -103	5253836	45 - 69	5261449	27 - 45		49 - 5
	29 - REF	5253845	45 - 82	5261450	27 - 59	5271294	38 - 51
2716280	12 -156	5257518	27 - 9	5261451	28 - 3	5271878	12 - 77
5112828	12 - 26	5261223	33 - 62		53 - 68	5275481	59 - 30
5150035	39A- 10	5261228	33 - 53	5261452	27 -103	5276180	11 - 48
5211036	11 - 12	5261229	33 - 70	5261453	27 - 63	5276181	10 - 38
5212657	27 - 41		34 - 57	5261454	28 - 76	5276183	10 - 44
5213022	53 - 49	5261236	44 - 78	5261456	27 - 1	5276187	10 - 45
5213274	59 - 21	5261239	44 - 17	5261457	28 - 77	5276188	10 - 39
5213276	53 - 67A	5261243	34 - 49		39 - 77	5276204	5 - 5
	53 - 78A	5261247	34 - 17		53 - 91A	5276216	9 - 24
5213306	55 - 21	5261248	34 - 62	5261458	28 - 25	5276218	9 - 6
5213400	43 - 45	5261266	43 - 54	5261459	28 - 38	5276219	10 - 23
5213402	33 - 43	5261267	43 -100		31 - 8	5276222	9 - 20
	33 - 47	5261276	43 - 78		32 - 12	5276227	9 - 18
	34 - 33	5261283	43 - 38		40 - 10	5276229	10 - 19
	34 - 37	5261286	43 - 14		41 - 10	5276231	7 - 9
	44 - 62	5261288	43 - 29	5261460	27 - 24	5276239	10 - 52
5213430	47 - 17	5261289	43 - 84		28 - 14	5276249	38 - 82
5213435	46 -151	5261296	43 - 74	5261461	27 - 98	5276250	38 - 99
5213436	46 -161		53 - 36A	5261463	27 - 40	5276270	45 - 75
5213466	41 - 1	5261304	27 - 31	5261465	27 - 43	5276271	45 - 76
5213479	27 - 47	5261306	43 - 75	5261466	28 - 70	5276286	46 -118
	46 -105	5261313	44 - 13	5261549	29 - 6	5276287	46 -127
5213492	11 - 37	5261314	33 - 29		29 - 16	5276288	46 -109
5213499	54 - 17		34 - 76	5261550	29 - 12	5276289	46 -113
5213729	38 -100	5261315	43 - 52	5261551	29 - 21	5276291	46 - 17
5213765	27 - 18		44 - 77	5261552	29 - 4	5276294	46 -137
5213803	46 -204		45 - 39		29 - 17	5276305	38 - 11
5213874	28 - 24		33 - 28	5261553	29 - 1	5276306	46 - 21
5213925	28 - 83		34 - 77		29 - 18		47 - REF
5214094	28 - 80		43 - 53	5261554	29 - 8	5276307	47 - 25
5214104	45 - 16		44 - 76	5261555	29 - 7	5276308	47 - 2
	53 - 98		45 - 38	5261556	29 - 3	5276309	47 - 13
5214119	52 - 27	5261316	43 - 60		29 - 20	5276313	30 - 48
5214143	59 - 61		44 - 2	5261557	29 - 2	5276322	39 - 13
5214167	46 - 43	5261317	43 - 70	5261558	29 - 9	5276325	38 - 50
5214173	5 - 19		44 - 33	5261559	29 - 11	5276326	53 -110
5214335	42 - 3	5261318	44 - 36	5261560	29 - 10	5276328	10 - 18
5214594	59 - 43A	5261320	44 - 71	5261561	29 - 14	5276329	46 -132
5214623	6 - 13	5261324	33 - 37	5261562	29 - 13	5276332	10 - 8
5214624	6 - 12	5261326	34 - 15	5261563	29 - 19	5276333	58 - 1
5214702	38 - 49	5261327	33 - 34	5261565	29 - 5	5276334	58 - 2
5235193	25 - 90		34 - 12	5261566	29 - 15	5276335	58 - 3
5235292	46 - 78	5261330	25 - 81	5261569	25 - 33	5276336	58 - 4
5235293	46 - 73	5261353	25 - 21	5261570	27 -122	5276347	9 - 13
5235365	46 -123	5261354	43 - 62	5261572	25 - 32	5276348	9 - 12
5236723	46 - 10		44 - 1	5261573	25 - 31	5276356	46 -148
5236960	48 - 3	5261355	27 - 96	5261574	25 - 30	5276359	47 - 9
	49 - 12	5261372	25 - 3	5261576	25 - 5	5276362	39 - 60
5236966	51 - 1	5261373	57 - 21	5261577	25 - 11		39 - 60
5236967	22 -110	5261379	43 - 51	5261591	25 - 14	5276363	39 - 62
	30 - 2		44 - 75	5261592	25 - 22		39 - 62
	37 - 10		45 - 40	5261594	25 - 13	5276364	46 -150
	37 - 13	5261381	25 - 10	5261595	25 - 12	5276366	5 - 16
	38 -109	5261382	25 - 28	5261596	27 - 97	5276367	5 - 24
	39 - 2	5261383	25 - 15	5261597	25 - 79	5276368	5 - 25
	46 - 2	5261388	28 - 50	5261598	25 - 35	5276370	30 - 53
5240462	28 - 20	5261412	33 - 27	5261599	26 - 20	5276474	59 - 5
5240477	33 - 36		34 - 18	5261608	25 - 92	5276475	59 - 5A
	34 - 14		43 - 11	5261629	25 - 20	5276490	58 - 5
	45 - 90		44 - 46	5261702	27 - 50	5276491	58 - 6
5240500	12 -120		45 - 4	5261779	34 - 22	5276497	10 - 32
	22 -119	5261416	27 - 62	5261789	33 - 6	5276587	18 - 36
	37 - 76	5261418	44 - 20		34 - 3	5276588	18 - 28
	51 - 26	5261419	44 - 55		43 - 57	5276589	18 - 47
5240501	12 - 7	5261423	44 - 48		44 - 6	5276590	18 - 32
5253796	45 - 41	5261426	27 - 90	5266044	45 - 65	5276591	18 - 24
5253797	45 -104	5261434	27 - 87	5266286	32 - 13	5276592	18 - 23
5253803	45 - 32	5261435	26 - 5	5270142	8 - 18	5276593	18 - 22
5253804	45 - 87		26 - 11	527C166	37 - 62	5276594	18 - 21
5253806	45 - 97	5261436	27 -109		37 - 64	5276595	18 - 39
5253807	45 - 23	5261437	27 -110	527C179	11 - 44	5276608	6 - 10
5253820	45 - 5	5261438	27 - 13	5270566	46 -101	5276644	9 - 25
5253822	45 - 91	5261439	28 - 26	5270586	46 - 34	5276703	25 - 62

PART NO.	FIGURE-INDEX NUMBER	PART NO.	FIGURE-INDEX NUMBER	PART NO.	FIGURE-INDEX NUMBER	PART NO.	FIGURE-INDEX NUMBER
5276703-CONT	53 - 55	5353027	12 - 93	5361886	38 - 12	5373130-CCNT	4 - REF
	57 - 12	5353028	12 - 41		38 - 81	5373131	1 - 13
5311086	1 - 163	5353087	14 - 31	5361892	38 - 78		4 - REF
5311421	11 - 27		23 - 29F	5362301	59 - 10	5373178	1 - 129
5311437	10 - 30	5353107	12 - 59	5362304	22 - 61	5373179	1 - 130
	10 - 50		12 - 110	5362305	22 - 60	5373180	1 - 127
	11 - 33		22 - 95A	5362314	9 - 1	5373223	14 - 5
	11 - 51	5353146	17 - 80		10 - 5		15 - 5
5311439	11 - 32	5353171	12 - 61	5362315	8 - 6		16 - 13
5311440	10 - 28	5353199	12 - 115		9 - 2		17 - 38
	10 - 48	5353216	15 - 41		10 - 4	5373660	10 - 31
	11 - 49	5353217	15 - 40	5363960	6 - 15		10 - 51
5312043	17 - 17	5353218	15 - 39	5363964	8 - 7		11 - 31
5312547	1 - 53	5353219	15 - 34	5363966	10 - 41		11 - 34
5313928	23 - 27	5353224	15 - 37	5363987	11 - 35		11 - 52
	24 - 43	5353277	12 - 43	5363991	11 - 45	5376712	38 - 43
5313943	56 - 15	5353278	12 - 31	5364197	53 - 109	5376713	38 - 42
5318920	35 - 22	5353280	12 - 44	5364198	53 - 111	5382447	11 - 25
5318966	38 - 57	5353281	12 - 35	5364225	30 - 38	5383166	11 - 5
5318967	38 - 54	5353282	12 - 35		39 - 44	5383167	11 - 53
5318968	38 - 47	5353287	12 - 113		39 - 44	5383181	7 - 5
5318969	38 - 52	5353288	12 - 13	5364276	53 - 112	5383203	8 - 14
5319854	1 - 28C	5353301	37 - 34	5366635	22 - 87	5383279	11 - 8
	12 - 1		37 - 38	5372693	59 - 31C	5383344	38 - 80
	14 - 45	5353335	12 - 41	5372711	12 - 96	5383345	38 - 70
	15 - 47	5353336	12 - 38	5372712	12 - 102	5383693	6 - 28
	23 - 29E	5353337	12 - 40	5372713	18 - 60	5393093	16 - 5
	24 - 58	5353339	12 - 29	5372714	18 - 55A	5393095	16 - 7
	45 - 14	5353853	13 - 23	5372715	12 - 105	5393226	1 - 114
5319888	12 - 8	5353854	13 - 24		18 - 56	5397691	1 - 48
	12 - 12	5353883	5 - 1	5372716	12 - 98	5397697	12 - 127
	12 - 97		11 - 1	5372743	12 - 10	5397714	1 - 18
	12 - 99	5353888	5 - 4	5372746	12 - 100	5397716	1 - 29
	12 - 101		8 - 2	5372760	1 - 31	5397740	1 - 66
	12 - 116		9 - 14		1 - 68	5397869	12 - 108
5319909	35 - 17		11 - 3	5372775	1 - 46	5397883	1 - 160
5319910	30 - 32		38 - 44	5372779	1 - 55	5397884	1 - 161
	39 - 24A	5353889	5 - 2	5372780	1 - 51	5399632	10 - 40
5323537	46 - 147		8 - 1	5372781	1 - 57	5400448	1 - 135
5327723	38 - 66		9 - 11	5372797	12 - 118	5400515	1 - 17
5349002	10 - 6		11 - 2		12 - 123	5400648	17A - 64
5349003	9 - 4	5353890	5 - 3		22 - 92	5400650	17A - 65
5349114	4 - 34		9 - 10	5372828	1 - 137	5400655	17A - 62
5349115	4 - 22	5356580	14 - 3	5372829	1 - 138D	5400656	17A - 48
5349116	4 - 20		15 - 3	5372831	1 - 139	5400657	17A - 49
5349118	4 - 17		16 - 11	5372855	1 - 33	5400658	17A - 60
5349125	4 - 19		17 - 36		1 - 70	5400661	17A - 78
5349152	4 - 24	5357002	12 - 48	5372856	1 - 71	5400662	17A - 77
5349174	4 - 28		13 - REF	5372858	1 - 27	5400663	17 - 18
5349192	4 - 34		23 - 17		12 - 45	5400666	17A - 45
5349195	4 - 28		24 - 33	5372859	12 - 94	5400675	17A - 115
5349203	5 - 18	5357005	13 - 4	5372866	1 - 116	5400689	17A - 4
	10 - 16	5357011	13 - 32	5372877	1 - 34	5400736	58 - 7
5349217	11 - 7	5357012	13 - 26	5372883	37 - 43	5400737	58 - 8
5349219	11 - 4	5357013	13 - 30	5372893	1 - 43	5400738	58 - 9
5349887	23 - 22	5357020	13 - 18	5372894	1 - 45	5400739	58 - 10
	24 - 38	5357021	13 - 25	5372895	1 - 41	5400740	58 - 11
5349888	13 - 27	5357035	23 - 18	5372905	1 - 115	5400741	58 - 12
5349929	22 - 17		24 - 34	5372921	1 - 85	5400742	58 - 13
	22 - 19	5357036	12 - 54	5372922	1 - 85	5400743	58 - 14
5349961	11 - 47	5357039	23 - 28	5372987	1 - 120	5400744	58 - 15
5350020	10 - 27		24 - 44	5372988	1 - 124	5400745	17A - 14
5351120	46 - 60	5357050	35 - 3	5372998	1 - 102	5400778	17A - 71
5351121	46 - 70	5357059	35 - 13	5372999	1 - 102	5400781	17A - 66
5351123	46 - 51	5357066	35 - 1	5373000	1 - 24	5400781	17A - 66
	46 - 66	5357061	35 - 12		1 - 26	5400799	17 - 78
5351139	38 - 53	5357062	35 - 9	5373001	1 - 23		17A - REF
	38 - 89	5357066	35 - 5		1 - 25	5403116	30 - 31
5351156	38 - 48	5357067	35 - 6	5373003	1 - 63		39 - 24B
	38 - 88	5357072	30 - 35	5373004	1 - 111	5403686	1 - 18
5351163	38 - 56		39 - 24C	5373015	1 - 110	5403698	1 - 17
	38 - 87	5357073	23 - 50	5373035	1 - 61	5403741	1 - 25
	45 - 22		24 - 56	5373048	1 - 87	5403742	1 - 26
5351173	59 - 22B	5357135	13 - 29	5373051	1 - 108	5403786	1 - 131
5351177	46 - 38	5357136	13 - 28	5373059	1 - 158	5403812	12 - 36
5351205	46 - 59		23 - 23	5373063	1 - 106	5403830	1 - 103
5351206	46 - 59		24 - 39	5373097	4 - 5	5403879	1 - 147
5352967	12 - 82A	5357137	13 - 11	5373126	4 - 32		1 - 152
5353026	12 - 86	5357144	13 - 15	5373128	4 - 8	5407422	1 - 28A
	22 - 33	5357145	13 - 14	5373129	4 - 32	5407424	1 - 132
				5373130	1 - 13	5407557	1 - 37

PART NO.	FIGURE-INDEX NUMBER	PART NO.	FIGURE-INDEX NUMBER	PART NO.	FIGURE-INDEX NUMBER	PART NO.	FIGURE-INDEX NUMBER
5407558	1 - 37	57C3220-CCNT	53 - 73	5709382	44 - 19	5713613	57 - 18
5407559	1 - 40	5703223	25 - 86	5709383	43 - 77	5713614	57 - 26
5407569	1 - 50		27 - REF	5709465	41 - 12	5713615	57 - 1
5408084	17A- 59	5703224	27 -124	5711771	11 - 28	5713630	54 - 14
5408090	17A- 53	5703226	27 -113	5712020	30 - 46	5713631	54 - 13
5408095	17A- 52	5703228	27 - 83		33 - REF	5713632	53 - 92
5408097	17A- 55	5703229	27 -116		39 - 31	5713633	53 - 95
5408098	17A- 57	57C323C	27 -114		39 - 31	5713634	53 - 88
5408113	17A- 44		28 - 68	5712023	25 - 73	5713635	53 - 85
5418186	1 -117A	57C3231	27 -100	5712024	25 - 99	5713636	53 -103
	1 -119A	5703233	27 - 98	5712025	25 - 75	5713637	53 -105
5418258	1 - 35	5703234	27 -117	5712027	26 - 18	5713638	53 - 74
5419406	9 - 3	5703235	27 -121	5712028	26 - 17	5713639	53 - 67F
5420365	1 - 72	57C3236	27 - 72	5712030	39 - 25	5713640	53 - 20
5420368	1 - 80	57C3237	27 - 85		44 - REF	5713641	53 - 61
5420369	1 - 74	57C3238	27 - 3	5712034	25 - 97		54 - REF
5420370	1 - 77	5703239	27 - 2	5712039	25 - 1	5713645	56 - 1
5420372	1 - 75	57C3241	27 - 46		26 - REF	5716291	12 -140
5420373	1 - 76A	5703242	25 - 17	5712040	30 - 47	5719452	46 -174
5420428	1 - 76	5703243	25 - 16		34 - REF	5719456	46 -183
5421373	22 - 97C	57C3244	27 - 57		39 - 32	5719775	52 - 23
5443252	4 - 11	57C3246	25 - 6	5712043	28 - 64	5719776	52 - 35
5443253	4 - 29	57C3247	25 - 70	5712044	27 - 33	5719777	52 - 33
5443254	4 - 29	57C3248	25 - 68	5712046	27 - 27	5719778	53 -113
5443255	4 - 25	5703249	25 - 66	5712080	39 - 29	5722002	30 - 78
5443256	4 - 25	57C3250	27 - 94		43 - REF	5722003	30 - 67
5443261	4 - 1	5703253	25 - 44	5713500	56 - 7	5722004	30 - 10
5443262	4 - 15	57C3255	25 - 55	5713501	52 - 17	5722005	30 - 24
5443263	4 - 30	57C3256	25 - 47	5713510	51 - 5	5722006	30 - 23
5443264	4 - 30		25 - 51		52 - REF	5722007	30 - 17
5443265	4 - 13	57C3257	27 - 25	5713513	52 - 37	5722008	30 - 49
5443266	4 - 13		28 - 15	5713514	52 - 16		35 - REF
5474732	4 - 3	57C3258	27 - 23	5713515	52 - 1	5722009	35 - 23
5493952	39 - 79		28 - 16	5713517	54 - 8	5722010	30 - 66
5493953	39 - 82	5703259	28 - 46	5713519	53 -107	5722011	30 - 71
5700650	25 -100	5703260	27 - 26	5713531	55 - 1	5722012	30 - 56
5702957	17A- 10		28 - 17	5713532	56 - 19	5722013	30 - 60
5702958	17A- 11	5703262	25 - 82	5713535	56 - 11	5722014	30 - 72
5702959	17A- 12	57C3264	27 - 21	5713536	55 - 24	5722015	30 - 73
5702960	17A- 5		28 - 12	5713537	56 - 8	5722016	30 - 58
5702966	17A- 72	5703265	28 - 33	5713538	56 - 6	5722018	22 - 96
5702968	17A- 51	5703276	17A- 22	5713539	56 - 9	5722021	30 - 57
5702973	17A- 21	5703279	17A- 8	5713540	55 - 26	5722023	30 - 62
5702975	17A- 39	5703282	17A- 90	5713541	55 - 27	5722024	30 - 64
5702976	17A- 19	5703283	17A- 98	5713542	55 - 18	5722028	24 - 60
5702977	17A- 15	5703284	17A- 95	5713543	55 - 22	5722036	30 - 61
	17A- 34	5703285	17A- 87	5713544	56 - 5	5722037	30 - 65
5702978	17A- 17	5703286	17A- 89	5713545	56 - 4	5722038	23 - 53
	17A- 35	5703287	17A-101	5713547	53 - 57	5722039	23 - 52
	17A- 28	5703328	17A- 1	5713548	55 - 11	5722043	22 - 18
5702987	17A- 27		30 - 44		56 - REF	5722044	22 - 14
5702990	17A- 83	5708902	31 - REF	5713549	55 - 12	5722045	22 - 15
5702995	17A- 85		39 - 27		56 - REF	5722046	22 - 16
5702996	17A- 79		39 - 27	5713550	55 - 29	5722049	22 - 94
5702998	17A-103	57C89C3	39 - 25	5713553	56 - 3	5722050	24 - 50
5703000	17A-102		40 - REF	5713556	55 - 8	5722051	24 - 49
5703001	17A-106	57C8908	39 - 25		55 - 12A	5722052	24 - 46
5703002	12 - 69		41 - REF	5713558	51 - 15	5722056	24 - 57
	17A- 73	57C8926	31 - 9		55 - REF	5722058	30 - 22
5703003	12 - 70	57C8927	40 - 11	5713561	56 - 13	5722059	30 - 21
5703004	17A-110	57C8928	41 - 14	5713562	56 - 2		30 - 25
5703006	17A- 82	57C8932	39 - 26	5713563	53 - 58	5722061	22 - 10
5703007	17 - 5		42 - REF		57 - 17	5722062	22 - 8
5703008	17A-117	57C8938	25 - 60	5713564	53 - 1	5722063	22 - 12
5703009	17A- 25	57C8939	33 - 21	5713568	55 - 19	5722064	22 - 9
5703052	17A- 70		34 - 23		55 - 23	5722066	22 - 34A
5703154	17A-111		43 - 4		56 - 12	5722067	22 - 31
5703155	17A- 40		44 - 41	5713571	53 - 53	5722071	30 - 43
5703200	22 - 83		45 - 7	5713572	53 - 52	5722079	37 - 50
	25 - REF		53 - 41	5713573	59 - 20	5722080	37 - 46
5703206	28 - 60	57C9CC4	30 - 45	5713574	59 - 63	5722081	38 -104
5703207	28 - 22		32 - REF	5713576	53 -119	5722091	58 - 16
5703211	28 - 51		39 - 28	5713577	53 - 5	5722101	37 - 81
5703212	28 - 9	57C9CC6	25 - 7	5713578	56 - 17	5722106	39 - 9
5703213	28 - 5	5709059	25 - 78A	5713590	51 - 10	5722107	39 - 20
	53 - 70	5709320	39 - 30		53 - REF	5722108	39 - 19
5703214	28 - 8		45 - REF	5713607	59 - 62	5722109	39 - 54
	53 - 69	57C9323	45 - 42	5713611	55 - 13	5722110	39 - 55
5703215	28 - 1	57C9325	45 - 10		57 - REF	5722111	39 - 50
5703220	28 - 4	57C9381	33 - 39	5713612	57 - 30	5722112	39 - 18

PART NO.	FIGURE-INDEX NUMBER	PART NO.	FIGURE-INDEX NUMBER	PART NO.	FIGURE-INDEX NUMBER	PART NO.	FIGURE-INDEX NUMBER
5722113	39 - 5	5759177	52 - 24	5781329-CONT	18 - REF	5781490	58 - 38
	39 - 17	5759216	22 - 40	5781339	22 - 35	5781491	58 - 39
5722114	39 - 52		22 - 57	5781340	5 - 9	5781497	22 - 43
5722115	39 - 53		51 - 12	5781343	58 - 18	5781498	22 - 47
5722119	38 - 112	5759502	8 - 3	5781344	58 - 19	5781499	22 - 45
5722121	37 - 28		9 - 35	5781345	58 - 20	5781512	39A- 15
5722122	37 - 31A		10 - 1	5781346	58 - 21	5781517	39A- 1
5722125	37 - 58		11 - 41	5781347	38 - 17	5781518	39 - 36
	37 - 68		18 - 15	5781348	58 - 22		39A- REF
	37 - 72	5759582	5 - 6	5781349	58 - 23	5781519	39A- 7
	51 - 22		6 - 1	5781351	51 - 31	5781520	1 - 91
5722132	37 - 74		7 - 1	5781352	12 - 134	5781521	1 - 90
5722133	38 - 1	5759995	41 - 13	5781353	12 - 136	5781522	1 - 16
5722143	39 - 85	5760027	41 - 13	5781354	22 - 52	5781524	1 - 16
5722144	39 - 85	5760047	41 - 13		22 - 70	5781527	16 - 47
5722145	46 - 96	5760071	41 - 13	5781355	22 - 65	5781528	1 - 92
5722159	46 - 184	5761493	25 - 8	5781356	22 - 64		1 - 96
5722159	46 - 6	5762034	28 - 90	5781357	22 - 49	5781531	6 - 4
5722259	37 - 70	5762073	46 - 42		22 - 67	5781532	6 - 5
	51 - 24	5762119	27 - 12	5781358	22 - 50	5781565	22 - 82
5723114	58 - 17	5762133	27 - 7		22 - 68	5781567	22 - 71
5723198	37 - 60	5762386	33 - 46	5781359	22 - 117	5781569	37 - 36
5723199	1 - 128		33 - 51	5781360	22 - 127	5781580	48 - 14
5723600	1 - 126		34 - 36	5781363	22 - 105A	5781581	49 - 17
5723632	37 - 16		34 - 42	5781364	24 - 61	5781758	23 - 45L
5723657	1 - 120		44 - 70	5781365	24 - 59	5781807	1 - 9
5723672	37 - 19	5762407	33 - 24	5781366	5 - 26	5781828	12 - 154
5723744	1 - 23		34 - 26	5781367	6 - 34		14 - 70
5723745	1 - 24	5762547	43 - 2	5781368	8 - 22		15 - 61
5723746	1 - 83	5762573	25 - 93	5781369	9 - 38		16 - 54
5723817	1 - 125	5765748	15 - 38	5781370	10 - 56	5781831	15 - 76
5723819	1 - 134	5769671	22 - 62	5781371	11 - 55	5781832	1 - 8
5726020	1 - 119	5779915	14 - 16	5781372	18 - 62	5781833	16 - 74
5726134	1 - 150		15 - 15	5781373	6 - 30	5781835	18 - 10
5726137	1 - 122		16 - 24	5781375	8 - 9	5781837	16 - 3
5726138	1 - 118	5779917	14 - 15	5781395	23 - 51	5781838	12 - 144
5726154	1 - 133		15 - 16	5781409	22 - 115		14 - 55
5726165	1 - 22		16 - 23	578141C	22 - 113		15 - 53
5726169	1 - 20		23 - 16	5781436	58 - 24	5781839	16 - 66
5726173	1 - 19		24 - 16	5781437	58 - 25	5781840	14 - 69
5726177	1 - 21	5781301	12 - REF	5781438	58 - 26		14 - 72
5726181	1 - 22	5781302	22 - REF	5781439	58 - 27		16 - 56
5726185	1 - 20	5781303	37 - REF	5781450	58 - 28	5781842	16 - 4
5726193	1 - 21	5781306	51 - 17	5781451	58 - 29	5781844	51 - 4
5726716	37 - 1C	5781307	12 - 83	5781452	37 - 41	5781845	16 - 81
5726736	37 - 54		14 - REF		49 - REF	5781886	22 - 95C
	51 - 18	5781308	12 - 84	5781453	37 - 39	5781889	22 - 30
5728086	23 - 29D		15 - REF		48 - REF	5781890	1 - 15
5728787	22 - 63	5781310	12 - 85	5781455	58 - 30	5781893	12 - 133A
5728860	23 - 29B		16 - REF	5781456	1 - 12	5782086	14 - 44
5728861	23 - 29A	5781311	22 - 88	5781459	58 - 31	5782239	12 - 4
5728862	14 - 28		30 - REF	5781460	12 - 158	5782240	12 - 3
5728863	14 - 27	5781314	22 - 28	5781461	5 - 20	5782243	1 - 15
5728864	14 - 25		23 - REF	5781462	11 - 9	5782244	12 - 92A
	23 - 29K	5781315	22 - 32	5781463	11 - 6	5782245	1 - 142
5728865	14 - 26		24 - REF	5781464	38 - 14	5782246	1 - 154
	23 - 29L	5781316	37 - 33	5781465	38 - 16	5782247	1 - 149
5728866	14 - 22		39 - REF	5781466	38 - 115	5782248	1 - 144
	23 - 29G	5781317	37 - 32	5781467	38 - 118	5782250	1 - 145
5728952	14 - 78		39 - REF	5781468	46 - 88	5782251	1 - 140
5729093	37 - 7	5781318	37 - 23	5781469	46 - 214	5782253	1 - 19
5733235	46 - 172		38 - REF	5781470	7 - 13	5782275	39 - 66
	46 - 178	5781319	37 - 37	5781471	9 - 29	5782276	39 - 84
	46 - 181		46 - REF	5781472	9 - 30	5782290	1 - 95
5733979	12 - 52	5781320	1 - 1	5781473	9 - 31	5782293	39 - 68
5736024	12 - 78		5 - REF	5781474	9 - 32	5782296	12 - 82B
5737411	15 - 46	5781321	1 - 2	5781475	9 - 33	5782297	1 - 94
5737491	6 - 6		6 - REF	5781476	9 - 34	5786801	56 - 10
5737684	12 - 28	5781322	1 - 3	5781479	58 - 32	5786802	55 - 25
5737685	12 - 27		7 - REF	5781480	46 - 11	5789779	57 - 16
5737686	12 - 16	5781323	1 - 4	5781481	46 - 30	5789803	57 - 20
5738338	33 - 32		8 - REF	5781483	58 - 33	5789831	53 - 66
5753531	12 - 53	5781324	1 - 5	5781484	58 - 34	5791040	37 - 1A
5753697	6 - 16		9 - REF	5781485	58 - 35	5791041	37 - 1B
5753698	6 - 9	5781325	1 - 6	5781486	30 - 26	5796431	10 - 17
5758602	26 - 1		10 - REF		39 - 21	5800610	59 - 4
5758610	26 - 4	5781326	1 - 7	5781487	30 - 33	5800667	59 - 4A
5758615	26 - 2		11 - REF		39 - 24E	5803299	59 - 4B
5758616	26 - 3	5781328	22 - 53	5781488	58 - 36	5820575	22 - 2
5759071	51 - 7	5781329	12 - 107	5781489	58 - 37	5820582	22 - 5